



**MTMDK-XDOT-AU1-A00**

Multi-Tech Systems

[Buy Now](#)



Looking for a discount?

[Check out our current promotions!](#)

Give us a call

**1-855-837-4225**

International: 1-415-281-3866

## Email Us

Sales and New Orders: [sales@verical.com](mailto:sales@verical.com)

Order Support: [support@verical.com](mailto:support@verical.com)

Suppliers: [Visit our seller page](#)

## Company Address

Arrow Electronics, Inc  
9201 East Dry Creek Road  
Centennial, CO 80112



## xDot® Developer Guide

---

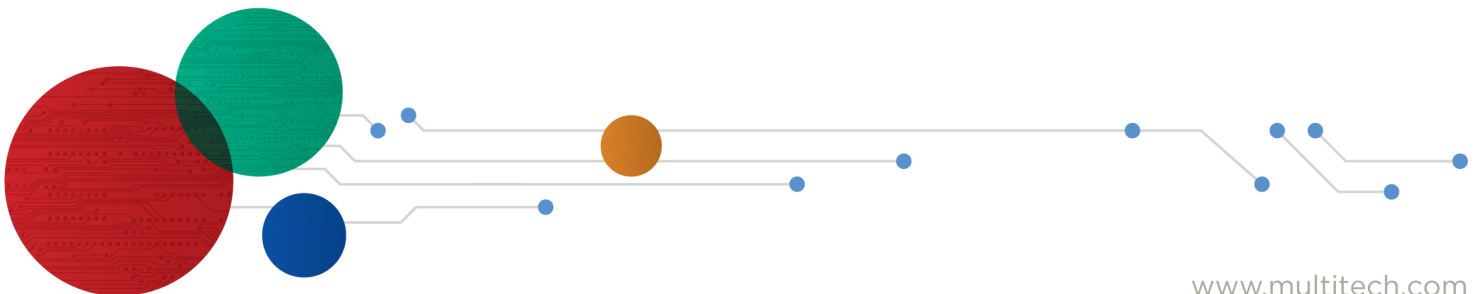

## MultiConnect xDot Developer Guide

Models: MTXDOT-NA1-xx , MTXDOT-EU1-xx , MTXDOT-AU1-xx, MTXDOT-AS1-xx , MTXDOT-EU1-IN1-xx , MTXDOT-KR1-xx

Part Number: S000645, Version 3.3

### Copyright

This publication may not be reproduced, in whole or in part, without the specific and express prior written permission signed by an executive officer of Multi-Tech Systems, Inc. All rights reserved. **Copyright © 2019 by Multi-Tech Systems, Inc.**

Multi-Tech Systems, Inc. makes no representations or warranties, whether express, implied or by estoppels, with respect to the content, information, material and recommendations herein and specifically disclaims any implied warranties of merchantability, fitness for any particular purpose and non-infringement.

Multi-Tech Systems, Inc. reserves the right to revise this publication and to make changes from time to time in the content hereof without obligation of Multi-Tech Systems, Inc. to notify any person or organization of such revisions or changes.

### Trademarks and Registered Trademarks

MultiTech, the MultiTech logo, MultiConnect, Conduit, and xDot are registered trademarks and mCard and mDot is a trademark of Multi-Tech Systems, Inc. All other products and technologies are the trademarks or registered trademarks of their respective holders.

### Legal Notices

The MultiTech products are not designed, manufactured or intended for use, and should not be used, or sold or re-sold for use, in connection with applications requiring fail-safe performance or in applications where the failure of the products would reasonably be expected to result in personal injury or death, significant property damage, or serious physical or environmental damage. Examples of such use include life support machines or other life preserving medical devices or systems, air traffic control or aircraft navigation or communications systems, control equipment for nuclear facilities, or missile, nuclear, biological or chemical weapons or other military applications (“Restricted Applications”). Use of the products in such Restricted Applications is at the user’s sole risk and liability.

MULTITECH DOES NOT WARRANT THAT THE TRANSMISSION OF DATA BY A PRODUCT OVER A CELLULAR COMMUNICATIONS NETWORK WILL BE UNINTERRUPTED, TIMELY, SECURE OR ERROR FREE, NOR DOES MULTITECH WARRANT ANY CONNECTION OR ACCESSIBILITY TO ANY CELLULAR COMMUNICATIONS NETWORK. MULTITECH WILL HAVE NO LIABILITY FOR ANY LOSSES, DAMAGES, OBLIGATIONS, PENALTIES, DEFICIENCIES, LIABILITIES, COSTS OR EXPENSES (INCLUDING WITHOUT LIMITATION REASONABLE ATTORNEYS FEES) RELATED TO TEMPORARY INABILITY TO ACCESS A CELLULAR COMMUNICATIONS NETWORK USING THE PRODUCTS.

The MultiTech products and the final application of the MultiTech products should be thoroughly tested to ensure the functionality of the MultiTech products as used in the final application. The designer, manufacturer and reseller has the sole responsibility of ensuring that any end user product into which the MultiTech product is integrated operates as intended and meets its requirements or the requirements of its direct or indirect customers. MultiTech has no responsibility whatsoever for the integration, configuration, testing, validation, verification, installation, upgrade, support or maintenance of such end user product, or for any liabilities, damages, costs or expenses associated therewith, except to the extent agreed upon in a signed written document. To the extent MultiTech provides any comments or suggested changes related to the application of its products, such comments or suggested changes is performed only as a courtesy and without any representation or warranty whatsoever.

### Contacting MultiTech

#### Knowledge Base

The Knowledge Base provides immediate access to support information and resolutions for all MultiTech products. Visit <http://www.multitech.com/kb.go>.

#### Support Portal

To create an account and submit a support case directly to our technical support team, visit: <https://support.multitech.com>.

#### Support

Business Hours: M-F, 8am to 5pm CT

Country	By Email	By Phone
Europe, Middle East, Africa:	<a href="mailto:support@multitech.co.uk">support@multitech.co.uk</a>	+(44) 118 959 7774
U.S., Canada, all others:	<a href="mailto:support@multitech.com">support@multitech.com</a>	(800) 972-2439 or (763) 717-5863

#### Warranty

To read the warranty statement for your product, visit <https://www.multitech.com/legal/warranty>. For other warranty options, visit [www.multitech.com/es.go](http://www.multitech.com/es.go).

#### World Headquarters

Multi-Tech Systems, Inc.  
 2205 Woodale Drive, Mounds View, MN 55112  
 Phone: (800) 328-9717 or (763) 785-3500  
 Fax (763) 785-9874

# Contents

<b>Chapter 1 – Product Overview</b> .....	<b>7</b>
Overview .....	7
What's New in Firmware Version 3.2 .....	7
LoRaWAN Version 1.0.3 Class B Support .....	7
Russian Channel Plan Support .....	7
AT Command Additions and Modifications .....	7
Documentation Overview .....	8
Related Documentation .....	8
mbed Documentation .....	8
Programming the xDot Microcontroller .....	8
General mBed Links .....	9
xDot Platform .....	9
EUI and Networking .....	9
Product Build Options .....	10
<b>Chapter 2 – Getting Started</b> .....	<b>11</b>
Getting Started with the xDot Developer Kit .....	11
COM Port Enumeration by Operating System .....	11
Linux .....	11
Windows .....	11
Mac .....	12
Updating Firmware Using the xDot Bootloader .....	12
<b>Chapter 3 – Mechanical Drawings with Pinouts</b> .....	<b>14</b>
xDot .....	14
<b>Chapter 4 – Specifications and Pin Information</b> .....	<b>15</b>
MTXDOT Specifications .....	15
North American Models (MTXDOT-NA1) .....	16
European Models (MTXDOT-EU) .....	17
Australian Models (MTXDOT-AU1) .....	18
Indian Models (MTXDOT-EU1-IN1) .....	19
South Korean Models (MTXDOT-KR1) .....	20
Asia Pacific Models (MTXDOT-AS1) .....	20
Battery Draw Down .....	22
Electrical and Timing Characteristics .....	22
Measuring the Power Draw .....	23
Pin Information .....	24
Pin Information .....	24
Pull-Up/Down .....	26

LoRa.....	26
Crystals/Oscillator .....	26
Sleep Wake and Deep Sleep Wake Pins .....	26
Interrupt Limitations .....	27
xDot Pinout Design Notes .....	28
Serial Pinout Notes.....	28
Serial Settings.....	28
LoRa .....	28
Throughput Rates.....	28
Range .....	28
Resetting the xDot .....	30
<b>Chapter 5 – Antennas .....</b>	<b>31</b>
Antenna System .....	31
U.FL and Trace Antenna Options .....	31
Pulse Electronics Antenna.....	32
Antenna Specifications .....	32
RSMA-to-U.FL Coaxial Cables .....	33
Coaxial Cable Specifications .....	33
Ethertronics Chip Antenna.....	34
Antenna Specifications .....	34
Stackup Information.....	34
Developer Board Layer Stackup.....	34
Stackup Table .....	35
Impedance .....	35
Chip Antenna Design Guidelines.....	37
Antenna Pad Layout.....	38
PCB Layout .....	38
Antenna Matching Network.....	39
915 .....	39
868 .....	40
OEM Integration .....	40
FCC & IC Information to Consumers .....	40
FCC Grant Notes.....	40
Host Labeling.....	41
<b>Chapter 6 – Safety Information .....</b>	<b>42</b>
Handling Precautions .....	42
Radio Frequency (RF) Safety .....	42
Sécurité relative aux appareils à radiofréquence (RF).....	42
Interference with Pacemakers and Other Medical Devices .....	43
Potential interference .....	43
Precautions for pacemaker wearers .....	43

Device Maintenance .....	43
User Responsibility.....	44
<b>Chapter 7 – Regulatory Information .....</b>	<b>45</b>
EMC, Safety, and Radio Equipment Directive (RED) Compliance .....	45
47 CFR Part 15 Regulation Class B Devices .....	45
<b>FCC Interference Notice .....</b>	<b>45</b>
FCC Notice .....	45
Industry Canada Class B Notice.....	46
<b>Chapter 8 – Environmental Notices .....</b>	<b>47</b>
Waste Electrical and Electronic Equipment Statement .....	47
WEEE Directive.....	47
Instructions for Disposal of WEEE by Users in the European Union .....	47
REACH Statement .....	47
Registration of Substances.....	47
Restriction of the Use of Hazardous Substances (RoHS) .....	47
Information on HS/TS Substances According to Chinese Standards .....	49
Information on HS/TS Substances According to Chinese Standards (in Chinese) .....	50
<b>Chapter 9 – Labels.....</b>	<b>51</b>
Label Examples.....	51
<b>Chapter 10 – Developer Kit Overview .....</b>	<b>52</b>
xDot Developer Kit .....	52
Developer Kit Package Contents.....	52
Firmware Updates.....	52
Programming Devices in Production .....	52
xDot Developer Kit Mechanical Drawings.....	53
Micro Developer Board LEDs .....	54
<b>Chapter 11 – Developer Board Schematics.....</b>	<b>55</b>
Assembly Diagrams and Schematics .....	55
Assembly Diagrams .....	55
Schematics .....	57
<b>Chapter 12 – Design Considerations.....</b>	<b>61</b>
Noise Suppression Design .....	61
PC Board Layout Guideline .....	61
Electromagnetic Interference .....	61
Electrostatic Discharge Control.....	62
<b>Chapter 13 – Mounting xDots and Programming External Targets .....</b>	<b>63</b>
Mounting the Device on Your Board .....	63
Solder Profile.....	63
Setpoints (Celsius).....	64
xDot Packing .....	64

- In-System Programming of xDot ..... 64
  - Schematic Example ..... 65
  - Recommended Programming Hardware for Production ..... 65
  - JTAG/SWD Connector ..... 66
- Chapter 14 – Appendix A Release Note Archive ..... 67**
  - What's New in Firmware Version 3.0 ..... 67
    - LoRaWAN 1.0.2 Support ..... 67
    - Listen Before Talk ..... 67
    - Separate Channel Plans ..... 67
  - What's New in Firmware Version 3.1 ..... 67
    - xDot Bootloader ..... 67
    - Power Optimization ..... 67
    - Other Enhancements ..... 68
- Index..... 69**

# Chapter 1 – Product Overview

## Overview

The MultiConnect xDot (MTXDOT) is a LoRaWAN™, low-power RF device, capable of two way communication over long distances, deep into buildings, or within noisy environments\* using the unlicensed ISM bands in North America, Europe and worldwide. The xDot is a compact surface-mount device with an mbed enabled processor and enhanced security. The xDot features an integrated ARM® Cortex®-M3 processor and mbed™ compatible software library for developers to control, monitor and bring edge intelligence to their Internet of Things (IoT) applications.

\*Actual distance depends on conditions, configuration, antennas, desired throughput, and usage frequency. In dense urban environments, a typical range is 1-2 miles.

## What's New in Firmware Version 3.2

The new release includes the following changes:

- LoRaWAN Version 1.0.3 Class B support
- Russian channel plan support
- New and updated AT Commands

### LoRaWAN Version 1.0.3 Class B Support

The LoRaWAN Class B option allows devices to open receive windows at fixed time intervals for server-initiated downlink messages.

New AT Commands: +PP - Ping slot periodicity and +BLS - Beacon lock status

### Russian Channel Plan Support

RU864-870 ISM band channel frequencies as described in LoRaWAN Version 1.0.3. This allows devices to operate in the 864 to 870 MHz frequency band and store parameters for at least eight channels.

### AT Command Additions and Modifications

**Note:** For AT Command details, refer to [S000643 DOT Series AT Command Reference Guide](#) .

- Deprecated AT+RECV and AT+RXF in production firmware versions
- Deprecated AT+AS.
- Added AT+PP - Ping slot periodicity.
- Added AT+FO - Frequency offset.
- Added AT+GPSTIME - Retrieving GPS synchronized time.
- Added AT+BAT - Device battery level.
- Added AT+BLS - Get the beacon's lock status
- Added AT+LBTRSSI - Listen Before Talk RSSI
- Added AT+SENDC - Sends data continuously
- Changed AT+RXO - Receive output

*For an archive of release notes, go to Appendix A.*

## Documentation Overview

This manual is one part of xDot documentation. Refer to the *Related Documentation* and *mbed* sections for additional information needed to program your xDot and integrate your application with the MultiConnect Conduit gateway.

This document includes:

- **xDot device information:** including mechanical drawings, specifications, safety and regulatory information, and other device specific content.
- **Developer Kit information:** including design considerations, schematics, and installation and operation information.

This current version of this manual is available at [www.multitech.com/support](http://www.multitech.com/support).

### Related Documentation

- **DOT Series AT Command Reference:** Includes details on the AT commands available for xDots.
- **MultiTech Developer Site:** Application notes, LoRa information, and documentation for related products such as the MultiConnect Conduit (MTCDDT) gateway and the LoRa accessory card (MTAC-LORA) are available on the MultiTech developer site. This site includes information on using the Conduit with xDots. Go to: [www.multitech.net](http://www.multitech.net)
- **Processor Datasheet:** ST ARM® Cortex®-M3 processor (STM32L151CCU6) datasheet is available on the ST website: <http://www.st.com/resource/en/datasheet/stm32l151cc.pdf>

## mbed Documentation

ARM mbed is a free, open-source platform and operating system for embedded devices using the ARM Cortex-M microcontrollers. The mbed website provides free software libraries, hardware designs, and online tools for rapid prototyping of products. The platform includes a standards-based C/C++ SDK, a microcontroller HDK, and supported development boards, an online compiler and online developer collaboration tools.

**Note:** To send and receive data, you need a LoRaWAN 1.0 gateway, such as MultiTech's MultiConnect Conduit (MTCDDT) with an MTAC-LORA accessory card installed.

### Programming the xDot Microcontroller

**Note:** To program an xDot application, you need the xDot Developer kit, which includes an xDot mounted on a developer board.

Use the ARM mbed ecosystem to program the microcontroller. Compile in the cloud or locally, copy the resulting binary file to the mbed USB drive, and reset the xDot.

On the xDot mbed page, MultiTech supplies source code for non-RF portions of the xDot. To comply with FCC and ETSI certification, some portions of the software is available only as binary libraries.

MultiTech offers both development and stable release versions of the library.

- Development version: libmxDot-dev-mbed5
- Stable release version: libmxDot-mbed5

You can use either the mbed online compiler or offline tools.

- Online: Use the mbed-os library in your mbed application

- Offline: Use mbed-cli tools to create, manage, and build your mbed 5.1 application.

## General mBed Links

- Explore mbed: <http://developer.mbed.org/explore>
- Getting Started with mbed: <http://developer.mbed.org/getting-started>
- mbed Handbook: <http://developer.mbed.org/handbook/Homepage>
- mbed online compiler documentation: <https://developer.mbed.org/handbook/mbed-Compiler>
- mbed cli documentation: <https://github.com/ARMmbed/mbed-cli/blob/master/README.md>
- mbed workspace tools documentation: <https://github.com/ARMmbed/mbed-os/blob/master/docs/BUILDING.md#workspace-tools>

## xDot Platform

The xDot mbed page includes the xDot library, firmware, and test cases

<https://developer.mbed.org/platforms/MTS-xDot-L151CC/>

## EUI and Networking

xDots have an Extended Unique Identifier (EUI). To query the device for the EUI, AT+DI:

```
AT+DI=<8-BYTE-HEX-MSB>
```

```
AT+DI=001122AABBCCDDEE
```

For information on setting up xDots as part of a LoRa network, go to [www.multitech.net](http://www.multitech.net).

## Product Build Options

Product	Description	Package Quantity
<b>North America</b>		
MTXDOT-NA1-A00	915 MHz LoRa Module UFL/TRC (NAM)	1, 100, or 1000
MTXDOT-NA1-A01	915 MHz LoRa Module TRC (NAM)	1, 100, or 1000
<b>EMEA</b>		
MTXDOT-EU1-IN1-A00	868 MHz LoRa Module UFL/TRC (EU)	1 or 100
MTXDOT-EU1-IN1-A01	868 MHz LoRa Module TRC (EU)	100
<b>Australia</b>		
MTXDOT-AU1-A00	AU915 MHz LoRa Module UFL/TRC (AU)	1 or 100
MTXDOT-AU1-A01	AU915 MHz LoRa Module TRC (AU)	100
<b>AS923</b>		
MTXDOT-AS1-A00	AS923 MHz LoRa Module UFL/TRC (APAC)	1 or 100
<b>Korea</b>		
MTXDOT-KR1-A00	KR920 MHz LoRa Module w/LBT UFL/TRC (KR)	1 or 100
<b>Developer Kits</b>		
MTMDK-XDOT-NA1-A00	MultiConnect xDot Micro Developer Kit - Includes a 915 MHz xDot	
MTMDK-XDOT-EU1-IN1-A00	MultiConnect xDot Micro Developer Kit - Includes a 868 MHz xDot	
MTMDK-XDOT-AU1-A00	MultiConnect xDot Micro Developer Kit - Includes a AU915 MHz xDot	
MTMDK-XDOT-AS1-A00	MultiConnect xDot Micro Developer Kit - Includes a AS923 MHz xDot	
MTMDK-XDOT-KR1-A00	MultiConnect xDot Micro Developer Kit - Includes a KR920 w/LBT MHz xDot	

**Note:**

- The complete product code may end in .Rx. For example, MTXDOT-NA1-A00.RxMTXDOT-EU1-IN1-A00.RxMTXDOT-AU1-A00.RxMTXDOT-AS1-A00.RxMTXDOT-JP1-A00.Rx, where R is revision and x is the revision number.

## Chapter 2 – Getting Started

### Getting Started with the xDot Developer Kit

Getting started depends on what you want to do. By default, xDot ships with firmware that supports AT Commands that use the serial I/O. For AT Commands, refer to the separate *MultiConnect Dots AT Command Reference Guide*.

Two serial interfaces are available through the USB interface, one is used to send AT commands to the xDot and the other is for debug messages. Refer to *Chapter 4, Specifications and Pin Information* for information on which pins are available out of the box.

Before starting your project development, make sure you have the latest firmware for the Developer Kit and xDot. Go to the xDot mbed page for firmware. <https://developer.mbed.org/platforms/MTS-xDot-L151CC/>

To send commands to the xDot:

1. Plug the developer board into a USB port.
2. Open communications software, such as TeraTerm, Putty, or Minicom.
3. Set the following:
  - Baud rate = 115,200
  - Data bits = 8
  - Parity = N
  - Stop bits = 1
  - Flow control = Off

To develop using Mbed, the xDot Mbed page includes libraries and test cases. Refer to [mbed Documentation](#) for details and links.

For help setting up a MultiConnect® Conduit® to send data to and from an xDot, refer to [Related Documentation](#).

### COM Port Enumeration by Operating System

xDots create an AT Commands port and a debug port.

#### Linux

The following COM ports are created on Linux systems:

- /dev/ttyACMx
- /dev/ttyACMy

Where x and y may be 0 and 1, 3 and 4, etc.

The COM port with lower number is the AT command port and COM port with the higher number is the debug port.

#### Windows

On Windows systems, COM ports appear in the Device Manager:

- **Debug Port:** Mbed Serial Port

- **AT Command Port:** XR21V1410 USB UART

You may need to install a driver for the debug port to function properly. Go to:

<https://developer.Mbed.org/handbook/Windows-serial-configuration>

## Mac

On Mac systems, COM ports appear in the Device Manager as:

- `/dev/cu.usbmodemx`

Where x is a string of numbers and possibly letters, ending in a number.

The COM port with lower number is the AT command port and COM port with the higher number is the debug port.

## Updating Firmware Using the xDot Bootloader

The xDot bootloader allows firmware upgrades either via YMODEM through command or debug serial ports at 115,200 bps.

To enter the bootloader, enter the characters xdt on either serial port upon processor reset. The bootloader allows 250ms for x and then 500 ms each for d and t. If these timers expire before receiving the proper character or another character is received, the bootloader jumps to the application code.

- The bootloader includes an option to upgrade application code via YMODEM or jump to the application code. During the YMODEM file transfer, the new application is programmed directly into the STM32L151CC flash memory.
- Since the new application is directly programmed into the STM32L151CC flash memory and the xDot has no on board memory to back up the old application, recovery from failed download is the responsibility of the host system.
- The Mbed build process creates two files when building for the bootloader. The `name_of_program_application.bin` file is the application with the correct offset that can be transferred via YMODEM onto the xDot using the bootloader. The `name_of_program.bin` file is the entire program with the bootloader than can be flashed on using jtag (this file cannot be transferred onto the xdot via YMODEM).

To build xDot firmware with the bootloader, you must include the `bootloader.bin` file in the `Mbed-os` directory along with an `Mbed_app.json` file that includes directives describing the space used for the bootloader and the location where the `bootloader.bin` file resides.

**Note:** For an application to run at the correct offset, it needs location where it will reside so the vector table is correct.

Mbed-os version 5.5.4, includes hooks that allow you to easily add a boot loader for the xDot. Go to

<https://docs.Mbed.com/docs/Mbed-os-handbook/en/latest/advanced/bootloader/> for details.

- For the bootloader, create a file with the following content. (Actual size may vary, but needs to accommodate the bootloader size.) Name the file `Mbed_app.json` and place it in the root directory.

```
{
  "target_overrides": {
    "XDOT_L151CC": {
      "target.restrict_size": "0x8000"
    }
  }
}
```

```
}
```

- For the application, create a file with the following content. Name it `Mbed_app.json` and place it in the root directory.

```
{  
  "target_overrides": {  
    "XDOT_L151CC": {  
      "target.bootloader_img": "bootloader_location/bootloader.bin"  
    }  
  }  
}
```

# Chapter 3 – Mechanical Drawings with Pinouts

## xDot

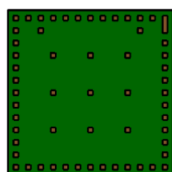
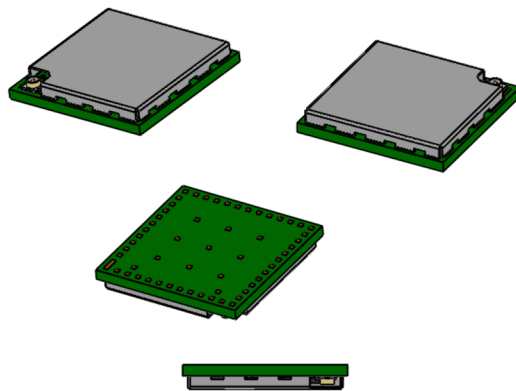
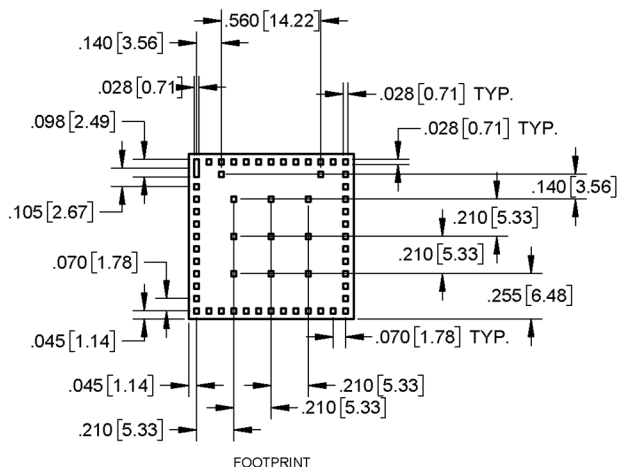

BOTTOM VIEW

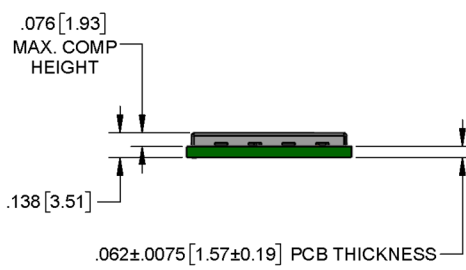
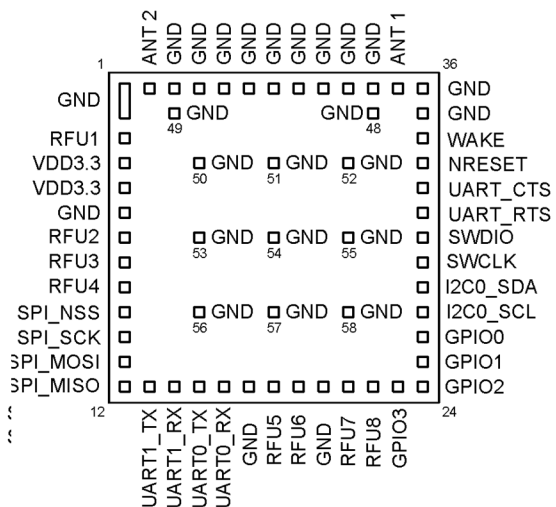
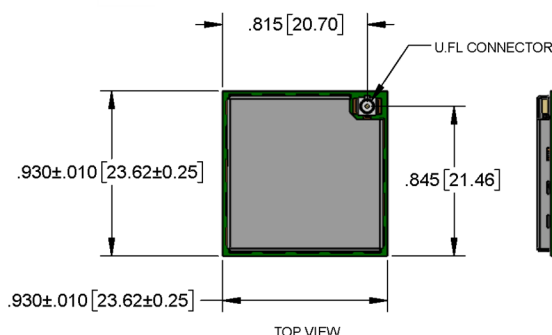

## XDOT

**Note:** The xDot development board uses a land pattern that matches the xDot land pattern in the previous image. All pads are 0.028 inches square except the large one, which is 0.098 inches x 0.028 inches.

## Chapter 4 – Specifications and Pin Information

### MTXDOT Specifications

Category	Description
<b>General</b>	
Compatibility	LoRaWAN 1.0 specifications
Interfaces	Note that pin functions are multiplexed.
	Up to 19 digital I/O
	Up to 10 analog inputs
	2 DAC outputs
	I2C
	SPI
	Wake pin
	Reset pin
	Full UART
	mbed/simple UART (RX & TX only)
mbed programming interface	
<b>CPU Performance</b>	
CPU	32 MHz
Max Clock	32 MHz
Flash Memory	256 KB, with xDot library 136 KB available; with AT firmware, 56 KB available
EEPROM	8 KB, available 6 KB
SRAM	32 KB
Backup Register	128 byte, available 88
<b>Physical Description</b>	
Weight	0.0001 oz. (0.003g)
Dimensions	Refer to Mechanical Drawings for Dimensions.
<b>RF Connectors</b>	
-UFL Models	U.FL
-Trace Models	Trace Connection
<b>Environment</b>	
Operating Temperature	-40° C to +85° C
Storage Temperature	-40° C to +85° C
Humidity	20%-90% RH, non-condensing

Category	Description
<b>Power Requirements</b>	
Operating Voltage	2.4 to 3.57 V

### North American Models (MTXDOT-NA1)

Category	Description
<b>Radio Frequency</b>	
ISM Bands	US902-928 MHz
<b>Certifications and Compliance</b>	
EMC	US: FCC Part 15 Class B
	Canada: ICES-003
Radio	FCC 15.247:2015
	FCC 15.109:2015
	FCC 15.107:2015
Safety	UL 60950-1 2nd ED
	cUL 60950-1 2nd ED
<b>Transmission</b>	
Max Transmitter Power Output (TPO)	19 dBm
Maximum Receive Sensitivity	-130 dBm
Link Budget <sup>1</sup>	147 dB Point-to-Point
	145 dB Point-to-Multipoint
Max Effective Isotropic Radiated Power (EIRP)	36 dBm
Deep Sleep Current	< 2 uA

Category	Description
<b>Receive Sensitivity</b>	
<b>Spreading Factor</b>	<b>North America<sup>2</sup></b>
6	-111 dBm
7	-116 dBm
8	-119 dBm
9	-122 dBm
10	-125 dBm
11	-127 dBm
12	-129 dBm

<sup>1</sup>Greater link budget is possible with higher gain antenna.

<sup>2</sup>RFS\_L500: RF sensitivity, Long-Range Mode, highest LNA gain, LNA boost, 500 kHz bandwidth using split Rx/Tx path.

## European Models (MTXDOT-EU)

Category	Description
<b>Radio Frequency</b>	
ISM Bands	EU863-870 MHz
<b>Certifications and Compliance</b>	
EMC	EN55022 Class B
	EN55024
	CISPR 22:2008
Radio	EN 300 220-2 V2.4.1:2012
	EN 301 489-03 V1.6.1:2013
Safety	IEC 60950-1 2nd ED AM1 & AM2
<b>Transmission</b>	
Max Transmitter Power Output (TPO)	14 dBm
Maximum Receive Sensitivity	-137 dBm
Link Budget <sup>1</sup>	147 dB Point-to-Point
	151 dB Point-to-Multipoint
Max Effective Isotropic Radiated Power (EIRP)	10 dBm
Deep Sleep Current	< 2 uA

Category	Description
<b>Receive Sensitivity</b>	
<b>Spreading Factor</b>	<b>EMEA<sup>2</sup></b>
6	-121 dBm
7	-124 dBm
8	-127 dBm
9	-130 dBm
10	-133 dBm
11	-135 dBm
12	-137 dBm

<sup>1</sup>Greater link budget is possible with higher gain antenna.

<sup>2</sup>RFS\_L125: RF sensitivity, Long-Range Mode, highest LNA gain, LNA boost, 125 kHz bandwidth using split Rx/Tx path.

### Australian Models (MTXDOT-AU1)

Category	Description
<b>Radio Frequency</b>	
ISM Bands	AU915-928 MHz
<b>Certifications and Compliance</b>	
EMC	AS/NZS CISPR 22 E
Radio	AS/NZS 4268:2012 + a1:2013
	MPE Standard 2014
Safety	AS/NZS 60950.1:2015
<b>Transmission</b>	
Max Transmitter Power Output (TPO)	19 dBm
Maximum Receive Sensitivity	-130 dBm
Link Budget <sup>1</sup>	147 dB Point-to-Point
	145 dB Point-to-Multipoint
Max Effective Isotropic Radiated Power (EIRP)	36 dBm
Deep Sleep Current	< 2 uA

Category	Description
<b>Receive Sensitivity</b>	
<b>Spreading Factor</b>	<b>Australia <sup>2</sup></b>
6	-111 dBm
7	-116 dBm
8	-119 dBm
9	-122 dBm
10	-125 dBm
11	-127 dBm
12	-129 dBm

<sup>1</sup>Greater link budget is possible with higher gain antenna.

<sup>2</sup>RFS\_L500: RF sensitivity, Long-Range Mode, highest LNA gain, LNA boost, 500 kHz bandwidth using split Rx/Tx path.

## Indian Models (MTXDOT-EU1-IN1)

Category	Description
<b>Radio Frequency</b>	
ISM Bands	IN865-867 MHz
<b>Certifications and Compliance</b>	
EMC	EN55022 Class B
	EN55024
	CISPR 22:2008
Radio	EN 300 220
Safety	IEC 60950-1 2nd ED AM1 & AM2
<b>Transmission</b>	
Max Transmitter Power Output (TPO)	14 dBm
Maximum Receive Sensitivity	-137 dBm
Link Budget <sup>1</sup>	147 dB Point-to-Point
	151 dB Point-to-Multipoint
Max Effective Isotropic Radiated Power (EIRP)	10 dBm
Deep Sleep Current	< 2 uA

Category	Description
<b>Receive Sensitivity</b>	
<b>Spreading Factor</b>	<b>India<sup>2</sup></b>
6	-121 dBm
7	-124 dBm
8	-127 dBm
9	-130 dBm
10	-133 dBm
11	-135 dBm
12	-137 dBm

<sup>1</sup>Greater link budget is possible with higher gain antenna.

<sup>2</sup>RFS\_L125: RF sensitivity, Long-Range Mode, highest LNA gain, LNA boost, 125 kHz bandwidth using split Rx/Tx path.

## South Korean Models (MTXDOT-KR1)

Category	Description
<b>Radio Frequency</b>	
ISM Bands	KR920-923 MHz
<b>Certifications and Compliance</b>	
EMC	Pending
Radio	Pending
Safety	Pending
<b>Transmission</b>	
Max Transmitter Power Output (TPO)	19 dBm
Maximum Receive Sensitivity	-130 dBm
Link Budget <sup>1</sup>	147 dB Point-to-Point
	145 dB Point-to-Multipoint
Max Effective Isotropic Radiated Power (EIRP)	36 dBm
Deep Sleep Current	< 2 uA

Category	Description
<b>Receive Sensitivity</b>	
<b>Spreading Factor</b>	<b>South Korea <sup>2</sup></b>
6	-111 dBm
7	-116 dBm
8	-119 dBm
9	-122 dBm
10	-125 dBm
11	-127 dBm
12	-129 dBm

<sup>1</sup>Greater link budget is possible with higher gain antenna.

<sup>2</sup>RFS\_L500: RF sensitivity, Long-Range Mode, highest LNA gain, LNA boost, 500 kHz bandwidth using split Rx/Tx path.

## Asia Pacific Models (MTXDOT-AS1)

Category	Description
<b>Radio Frequency</b>	
ISM Bands	AS920-923 MHz ("AS1")

Category	Description
<b>Transmission</b>	
Max Transmitter Power Output (TPO)	19 dBm
Maximum Receive Sensitivity	-130 dBm
Link Budget <sup>1</sup>	147 dB Point-to-Point
	145 dB Point-to-Multipoint
Max Effective Isotropic Radiated Power (EIRP)	36 dBm
Deep Sleep Current	< 2 uA

Category	Description
<b>Receive Sensitivity</b>	
<b>Spreading Factor</b>	<b>Asia Pacific<sup>2</sup></b>
6	-111 dBm
7	-116 dBm
8	-119 dBm
9	-122 dBm
10	-125 dBm
11	-127 dBm
12	-129 dBm

<sup>1</sup>Greater link budget is possible with higher gain antenna.

<sup>2</sup>RFS\_L500: RF sensitivity, Long-Range Mode, highest LNA gain, LNA boost, 500 kHz bandwidth using split Rx/Tx path.

## Battery Draw Down

xDot battery life depends on many variables, including transmit power, data rate, sleep usage, and duty cycle. The following figure represents the current consumption in one possible application.

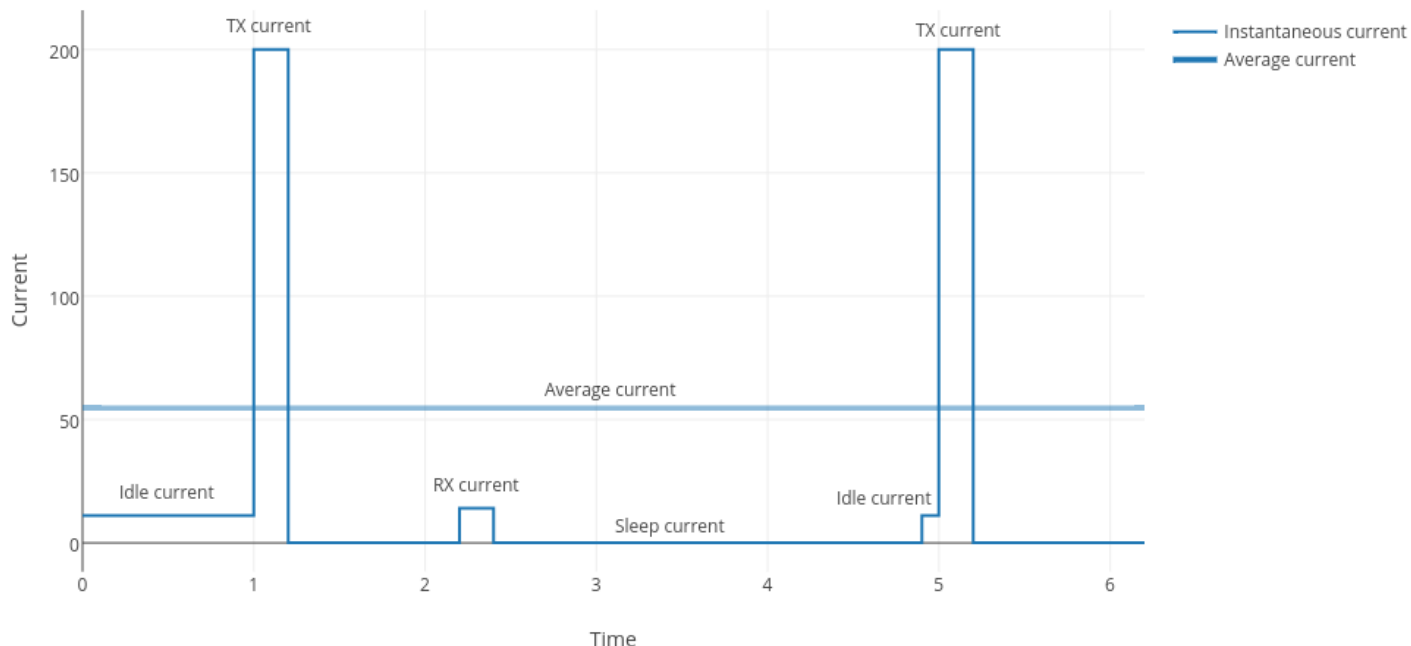

Use the current consumption values from the following Electrical Characteristics table when calculating average power consumption.

### Electrical and Timing Characteristics

**Note:**

- All measurements taken at VDD = 3.3 V and 25 degrees Celsius ambient temperature unless otherwise specified.
- Refer to the ST Micro STM32L151CC datasheet for more detailed processor IO characteristics.

Signal	Description	Conditions	Min	Typical	Max	Units
VCC	Operating Voltage		2.4	3.3	3.57	V
Vin Low	IO input low level		--	--	0.3V * VDD	V
Vin High	IO input high level		0.45 * VDD + 0.6			V
Vout Low	IO output low level	Pin current = 8mA	-		0.4	V
Vout High	IO output high level	2.7V < VDD < 3.6V	VDD - 0.4			V
Vout Low	IO output low level	Pin current = 20mA	--		1.3	V
Vout High	IO output high level	2.7V < VDD < 3.6V	VDD - 1.3			V

Signal	Description	Conditions	Min	Typical	Max	Units	
ICC		Idle mode (no TX, no RX), processor active	--	11.1		mA	
		TX, TXP=2	--	50		mA	
		TX, TXP=11	--	62.5		mA	
		TX, TXP=20	--	120		mA	
		Maximum supply current. Transmitting at TXP=20, all peripherals active, no load on IO pins. VDD = 3.3V. 25 degC ambient temperature.	--	--	250		mA
		Sleep mode	--	2.1	--	uA	
		Deep sleep mode	--	1.8	--	uA	
		RX	--	26.8	--	mA	
T <sub>NRESET</sub>	NRESET minimum pulse duration	--	1	--	--	ms	
V <sub>NRESET</sub> Low	NRESET input low level	--	--	--	0.3 * VDD	V	
V <sub>NRESET</sub> High	NRESET input high level	Note: The xDot has an internal pull-up resistor.	0.39 * VDD + 0.6	--	--	V	

## Measuring the Power Draw

To measure the power draw on an xDot developer board:

1. Flash the latest AT command firmware on the xDot.
2. Unplug the xDot from the computer and then reconnect it.
3. Connect current meter across JP30 on the developer board.
4. Set wake pin to wake, **AT+WP=6**.
5. Set wake mode to interrupt, **AT+WM=1**.
6. Put the xDot to sleep, **AT+SLEEP=0|1**.
7. Put jumper across JP5.  
**Note:** After this step, AT command and debug ports no longer work.
8. Measure current draw.
9. Press the **S2** button on the developer board to wake the xDot

## Pin Information

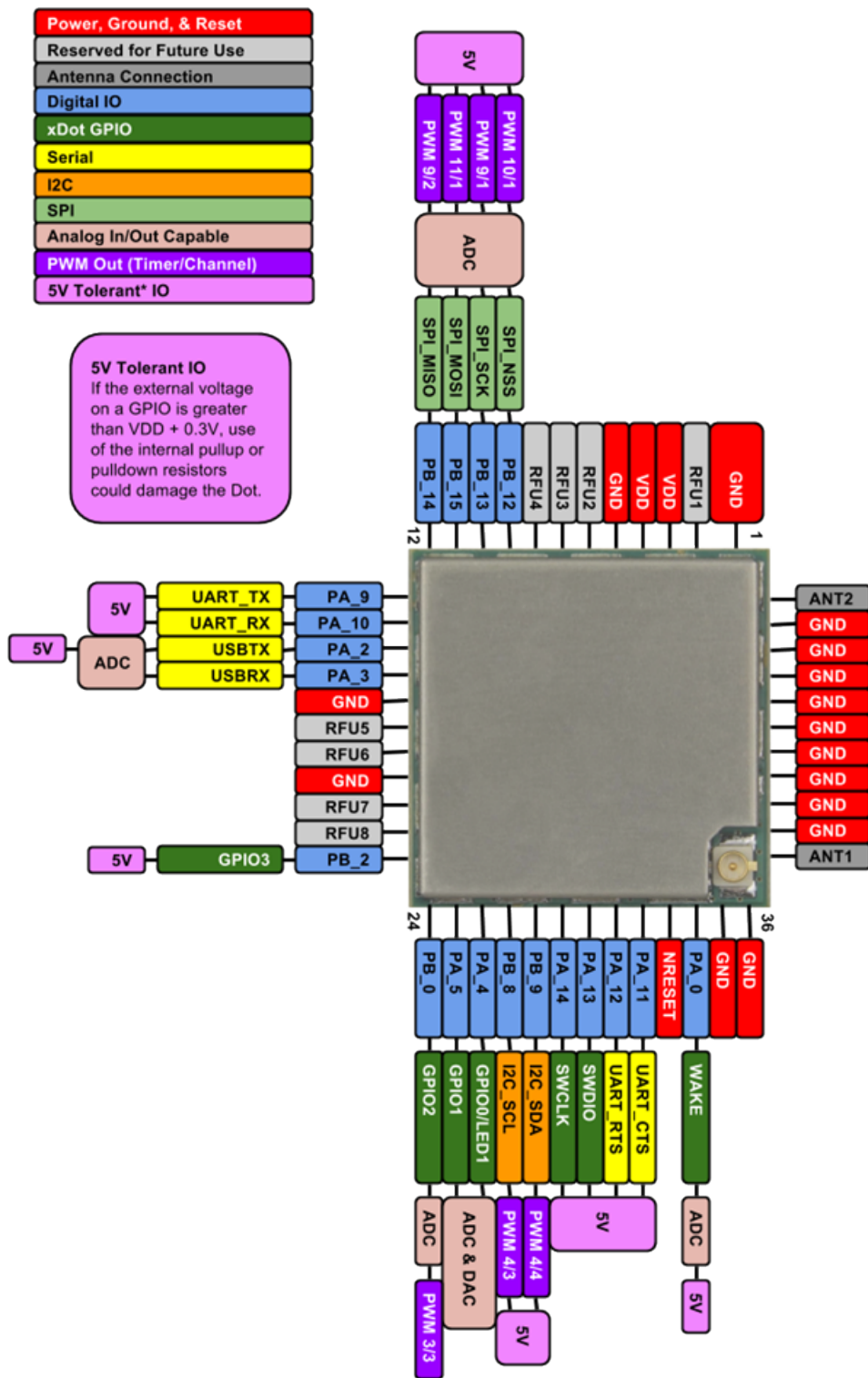

## Pin Information

**Note:**

- Using the mbed platform expands your pin functionality options.

- Pins are on a 0.07 inch grid, and are 0.028 inches square (except for upper left)
- The xDot is 0.045 x 0.045, board is 0.93 x 0.93

xDot Pin	STM32L151CCU6 (Where applicable)	SW Name	Notes
9	PB12	SPI_NSS	
10	PB13	SPI_SCK	
11	PB15	SPI_MOSI	
12	PB14	SPI_MISO	
13	PA9	UART_TX	
14	PA10	UART_RX	
15	PA2	USBTX	Debug TX routes to USB on developer board
16	PA3	USBRX	Debug RX routes to USB on developer board
23	PB2	GPIO3	
24	PB0	GPIO2	
25	PA5	GPIO1	
26	PA4	GPIO0	
27	PB8	I2C_SCL	
28	PB9	I2C_SDA	
29	PA14	SWCLK	
30	PA13	SWDIO	
31	PA12	UART_RTS	
32	PA11	UART_CTS	
33	NRST		
34	PA0-WKUP1	WAKE	Wake up from low power modes on rising edge
37			ANT1
47			RFU (ANT2)
1, 5, 17, 20,35, 36, 38, 39, 40, 41, 42, 43, 44, 45, 46, 48, 49, 50, 51, 52, 53, 54, 55, 56, 57, 58	VSS		Ground
3, 4	VDD		
2, 6, 7, 8, 18, 19, 21, 22			Reserved

## Pull-Up/Down

xDot Pin	Pin Name	SW Name	PU/PD
33	NRST		10k PU
	PA15	LORA_NSS	100k PU
	BOOT0		10k PD
	PB3	LORA_SCK	100k PD
	PB5	LORA_MOSI	100k PD

## LoRa

Pin	Function
PA6	LORA_DIO0
PA7	LORA_DIO1
PA8	LORA_DIO2
PB1	LORA_DIO3
PC13	LORA_DIO4
PB4	LORA_MISO
PB5	LORA_MOSI
PA15	LORA_NSS
PA1	LORA_RESET
PB3	LORA_SCK

## Crystals/Oscillator

Pin	Description
PC14-OSC32_IN	Real-time clock
PC15-OSC32_OUT	Real-time clock
PH0-OSC_IN	High speed system clock
PH1-OSC_OUT	High speed system clock

## Sleep Wake and Deep Sleep Wake Pins

Pin	Description
Sleep Wake	
PA9	UART1_RX
PA4	GPIO0
PA5	GPIO1
PB0	GPIO2

Pin	Description
PB2	GPIO3
PA0	Wake
Deep Sleep Wake	
PA0	Wake

## Interrupt Limitations

Due to the processor's architecture, only one port of the same number (e.g. PA\_1, PB\_1, PC1, etc) may be configured as an Interrupt source. If you configure multiple ports of the same number as an Interrupt source, only the last one configured will actually trigger an interrupt in the processor. The rest will be ignored.

**Note:** The LoRa radio uses interrupts 1, 6, 7, 8, and 13. Do not configure these as external interrupts. Doing so breaks the LoRa functionality and causes undefined behavior.

For example, if you configure the WAKE (PA\_0) pin to wake the xDot from low power modes and then you cannot configure GPIO2 (PB\_0) as an Interrupt source. If you do so, the WAKE pin will not wake the xDot as desired.

For more information about this, refer to the ST RM0038 Reference Manual at [https://www.st.com/content/st\\_com/en/search.html?q=RM0038-t=resources-page=1](https://www.st.com/content/st_com/en/search.html?q=RM0038-t=resources-page=1)

## xDot Pinout Design Notes

Refer to the mechanical drawing for your model for pin locations.

- All pins that go to connectors are directly connected to the processor.
- Refer to [Pin Information](#) table for pull up and pull down information.

xDots allow you to program pins depending on your application:

- **Serial:** Available out of the box. See Serial Pinout Notes for details.
- **mbed:** Designed with the STM32L151CCU6 48-pin processor, this option provides the most flexibility. For more information about processor capabilities, see the processor datasheet.

### Serial Pinout Notes

These pins are available for serial applications. If using AT firmware, serial pins are the AT command port. If writing an app, you need to configure the UART before using.

Refer to the pinout image for pin locations.

- 13 PA9 UART\_TX
- 14 PA10 UART\_RX
- 31 PA12 UART\_RTS
- 32 PA11 UART\_CTS

## Serial Settings

When creating a serial connection with the device on the developer board, open communications software (such as TeraTerm, Putty, or Minicom ), and use the following settings:

- Baud rate = 115,200
- Data bits = 8
- Parity = N
- Stop bits = 1
- Flow control = Off

## LoRa

### Throughput Rates

Theoretical maximum speeds for LoRa mode with ACKs off are:

- Using spreading factor 7 at 125kHz, the throughput rate is 5470 bps (5.47 kbps).
- Using spreading factor 7 at 500kHz the receiving throughput rate is 21900 bps (21.9 kbps).

**Note:** Data rates in the LoRaWAN specification vary by geographic region.

### Range

Variables effecting the range include TX power, antenna gain, RX sensitivity, fade margin, earth's curvature. Use the following formula to calculate the maximum range:

$$Range_{Miles} = 10^{\left(\frac{TxPower + Antenna\ gain\ total - RX\ Sensitivity - Fade\ Margin - 36.56}{20} - LOG_{10}(F_{MHz})\right)}$$

The following table provides example settings and the theoretical maximum range based on these settings.

Example	18dB Transmit Power for 915 MHz Models	Units	Example 14dB Transmit Power for 868MHz Models
Frequency	915	MHz	868
TX Power	19	dBm	14
TX Antenna Gain	3	dB	3
RX Sensitivity <sup>1</sup>	-120	dBm	-120
RX Antenna Gain	3	dB	3
Fade Margin <sup>2</sup>	30	dB	30
Distance	8.14	Miles	5.41
Distance	13.08	Km	8.70

<sup>1</sup>RX Sensitivity is set to a conservative -120dBm, but can vary from -117 to -137dBm.

<sup>2</sup>Fade Margin is set at the worst case of 30dB. Fade margin is an allowance a system designer includes to account for unknown variables. The higher the fade margin, the better the overall link quality will be. With a fade margin set to zero, the link budget is still valid, but only in LOS conditions, which is not practical for most designs. The amount of fade margin to include in a calculation depends on the environment in which you will deploy the system. A fade margin of 12 dBm is good, but a better number would be 20 to 30 dBm.

## Resetting the xDot

To reset the xDot

1. Drive the RESET signal low for at least  $T_{NRESET}$ .
2. Select either:
  - Allow RESET to float. The internal pull-up resistor pulls it up.
  - Drive the RESET line high.

The processor starts executing code after the RESET line is high.

## Chapter 5 – Antennas

### Antenna System

The LoRa antenna performance depends on the implementation and antenna design. The integration of the antenna system into the product is a critical part of the design process; therefore, it is essential to consider it early so the performance is not compromised. If changes are made to the device's certified antenna system, then recertification will be required.

This radio transmitter has been tested with both the Pulse and Ethertronics antennas listed below. If you follow our design guidelines, you do not need to re-certify your design. The antenna you use must maintain the same specifications. It must be of the same type, with similar in-band and out-of-band radiation patterns. Antennas having a greater gain than the maximum gain indicated for the listed type, are strictly prohibited for use with this device.

### U.FL and Trace Antenna Options

If using U.FL or trace antennas, note the following:

- **For a simple trace to RF antennas:** Routing must follow standard RF design rules and practices for stripline/microstrip for a 50 ohm impedance line. Use the developer board schematics for a reference circuit for the a trace antenna.
- **For U.FL antennas:** The antenna and cable combination in your design cannot exceed the performance of the SMA antenna as listed in the next topic.
- The xDot Developer Board includes an Ethertronics M620720 chip antenna, which by default connects the xDot to the chip antenna. Only one antenna, either U.FL or chip, may be used at a time.  
**Note:** To use the xDot's U.FL connector, remove resistor C23 and L1, marked on the following image, to disconnect the chip antenna.
- To use the U.FL connector on the xDot, do not connect anything to ANT1 (pin 37) or ANT2 (pin 47).
- To design a custom antenna (PCB trace antenna, chip antenna, PCB trace leading to external antenna connection) do not connect anything to the U.FL connector. Use either ANT1 or ANT2, not both.

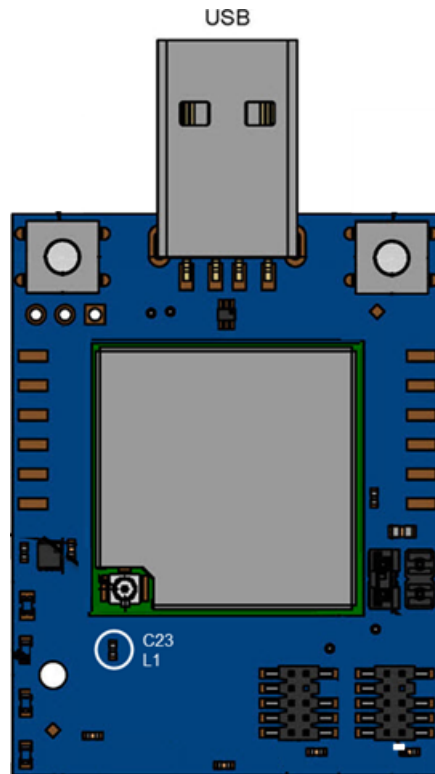

## Pulse Electronics Antenna

Manufacturer:	Pulse Electronics
Description:	868-928 MHz RP-SMA Antenna, 8"
Model Number:	W1063
MultiTech Part Number:	45009830L

### MultiTech ordering information:

Ordering Part Number	Quantity
AN868-915A-1HRA	1
AN868-915A-10HRA	10
AN868-915A-50HRA	50

## Antenna Specifications

Category	Description
Frequency Range	868-928 MHz
Impedance	50 Ohms
VSWR	$\leq 2.0$
Gain	3.0 dBi
Radiation	Omni

Category	Description
Polarization	Vertical

## RSMA-to-U.FL Coaxial Cables

### Coaxial Cable Specifications

Optional antenna cables can be ordered from MultiTech

Cable Type	Coaxial Cable
Attenuation	<1.0db
Connector Impedance	50 ohm
Maximum Cable Length	16" (40 cm)

### Ordering Information

Part Number	Description
CARSMA-UFL-1	RSMA-to-UFL Coax Cable (Single Pack)
CARSMA-UFL-10	RSMA-to-UFL Coax Cable (Ten Pack)
CARSMA-UFL-100	RSMA-to-UFL Coax Cable (One Hundred Pack)

## Ethertronics Chip Antenna

This is the developer board's default antenna.

Manufacturer:	Ethertronics
Description:	915MHz Chip RF Antenna 902MHz ~ 928MHz 2.56dB Solder Surface Mount
Model Number:	M620720
Datasheet:	<a href="https://www.ethertronics.com/wp-content/uploads/2016/11/M620720-ISM-868-915MHz-Ethertronics-Savvi-Ceramic-antenna-datasheet-20161020.pdf">https://www.ethertronics.com/wp-content/uploads/2016/11/M620720-ISM-868-915MHz-Ethertronics-Savvi-Ceramic-antenna-datasheet-20161020.pdf</a>

### Antenna Specifications

Category	Description
<b>Electrical Specifications</b>	
Frequency Range	868-870 MHz, 902-928 MHz
Peak Gain	2.56 dBi
VSWR	2:6:1 max
Impedance	50 ohms unbalanced
Average Efficiency	58%
Power Handling	0.5 Watt CW
Polarization	Linear
<b>Mechanical Specifications</b>	
Mounting	Surface Mount
Size	6.00 x 2.00 x 1.1mm

### Stackup Information

#### Developer Board Layer Stackup

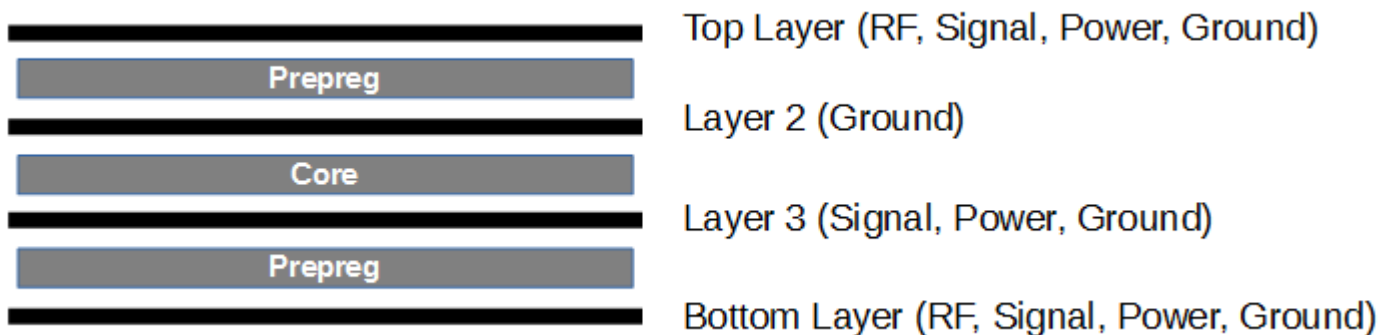

## Stackup Table

Part Number: 10000952L

PDF Date: Friday, August 12, 2016 01:42:30 PM



### Stackup S02

PCB Fabricator: APCB-Taiwan

Created/Modified: 07-10-2012 / 12-31-2015

Soldermask Type: DSR-220TL 06BL (Blue)

Measured Thickness:

Surface Finish: High Temp. OSP

Stackup Notes: White Silkscreen Blue Soldermask

Layer	Layer Type	Construction	Dk	T (mils)	W (mils)	D (mils)	Z <sub>0</sub> (ohms)	Z <sub>min</sub> /Z <sub>max</sub> (ohms)	Z <sub>diff</sub> (ohms)
1	Signal	0.5 oz. Copper	—	1.6/-	11/- 8/-	22/- 7/-	50±10%/-	45/55	90±10%/-
.	Prepreg (TU-72P-1MHz)	7628 (43%)	4.2	7.1	—	—	—	—	—
2	Plane	1 oz. Copper	—	1.4/-	—	—	—	—	—
.	Core (TU-722-1MHz)	5x7628	4.63	39	—	—	—	—	—
3	Signal	1 oz. Copper	—	1.4/-	—	—	—	—	—
.	Prepreg (TU-72P-1MHz)	7628 (43%)	4.2	7.1	—	—	—	—	—
4	Signal	0.5 oz. Copper	—	1.6/-	8/-	7/-	—	—	90±10%/-

## Impedance

Polar trial balance (L1 refer to L2) impedance 50.87 ohms, using 11 mil tracs, 22mil space.

Example.Zo - CITS25 Differential Controlled Impedance Calculator

File Structure Help

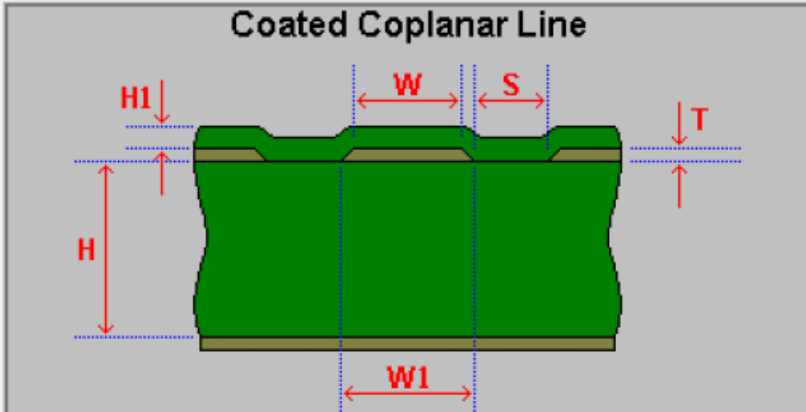

**Coated Coplanar Line**

Height (H): 7.1  
 (H1): 0.8

Track (W): 10  
 (W1): 11

Ground (W2):  
 Plane (W3):

Thickness (T): 1.6

Separation (S): 22

Dielectric (Er): 4.2

Notes:  Lower Ground Plane

Impedance Calculated

Impedance (Zo): 50.87

Delay (ps/in): 156.75

**Polar** World Leaders in PCB Faultfinding and Controlled Impedance Measurement

Polar trial balance (L1 refer to L2/L4 refer to L3) impedance 93.54 ohms, using 8 mil tracs, 7mil space.

**Edge-coupled Coated Microstrip**

Notes:  
Add your comments here

**Polar**  
*World Leaders in PCB  
Faultfinding and Controlled  
Impedance Measurement*

Height (H):	7.1
Height1 (H1):	0.8
Width (W):	7
Width1 (W1):	8
Separation (S):	7
Thickness (T):	1.6
Dielectric Constant (Er):	4.2
Impedance Calculated	
Differential Impedance (Zo):	93.54
Delay (ps/in):	152.99

## Chip Antenna Design Guidelines

When designing antenna placement for the chip antenna, note the following:

- The antenna's long side must be along the edge of the ground plane.
- Remove the ground plane from all layers below the antenna.
- The distance from the antenna to the enclosure or plastic cover should be greater than 1.5 mm.

The distance from the antenna to relatively large perturbations, such as a shield or large components, depends on the height of surrounding components. It should not be less than 1.5mm.

We recommend a distance equal to or greater than 10mm from the end of the antenna to either end of the PCB distance. Performance is better from larger distances.

Use the recommended land pattern shown in the figures below. Land patterns are composed of a 50 ohm line connected to each antenna feed point. Ground clearance around and under the antenna as shown in the PCB layout is recommended to maximize antenna performance.

## Antenna Pad Layout

Antenna Pad Layout

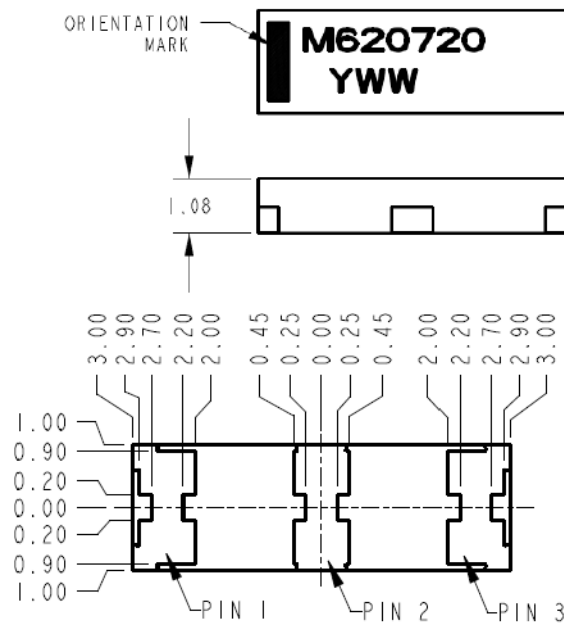
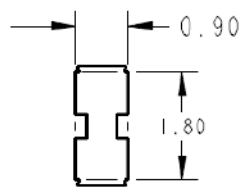

Pin	Description
1	ISM Feed/ Minor Matching Circuit Connection
2	Dummy Pad
3	Matching Circuit Connection

## PCB Layout

PCB Layout

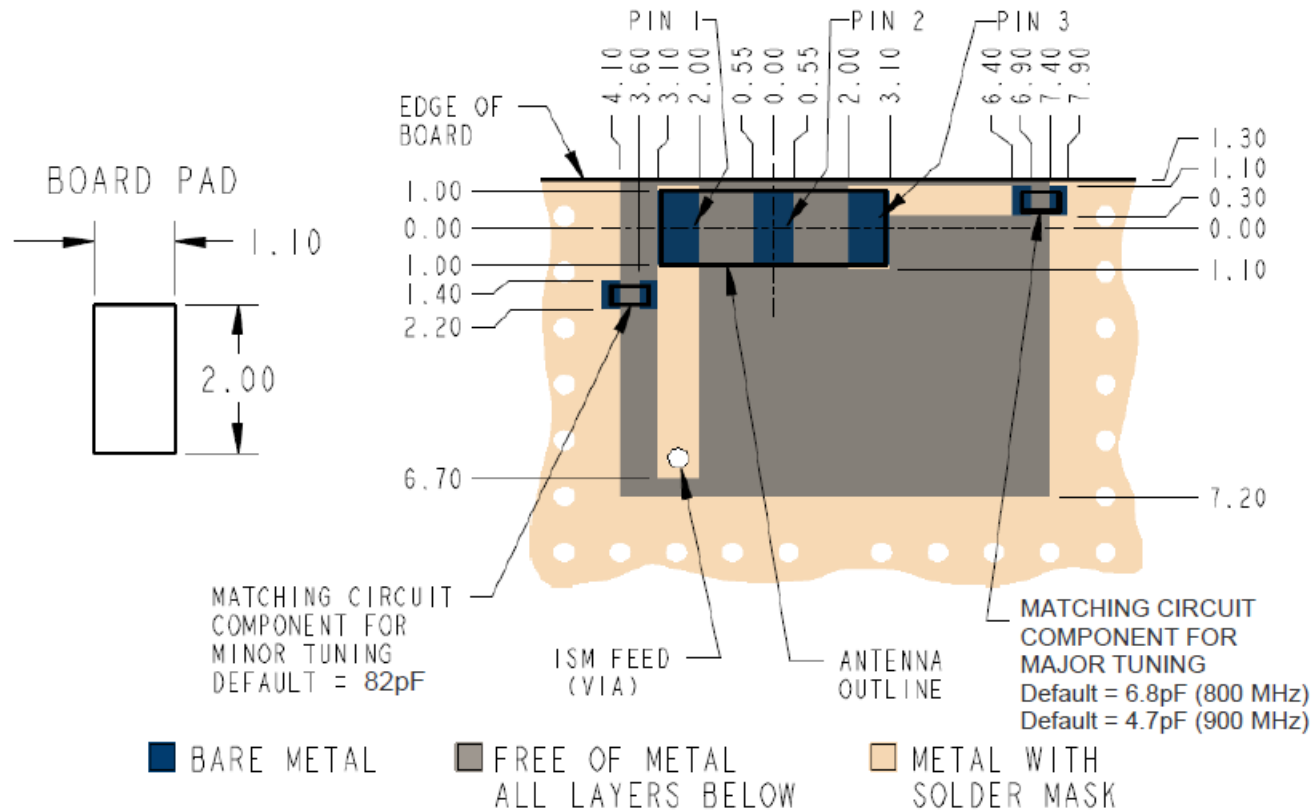

# Antenna Matching Network

The following images come from the xDot Developer Board schematics and show component populations for the antenna tuning circuit. The values you use depend on which frequency band you are using, 898 MHz or 915 MHz

## 915

### MultiTech xDot

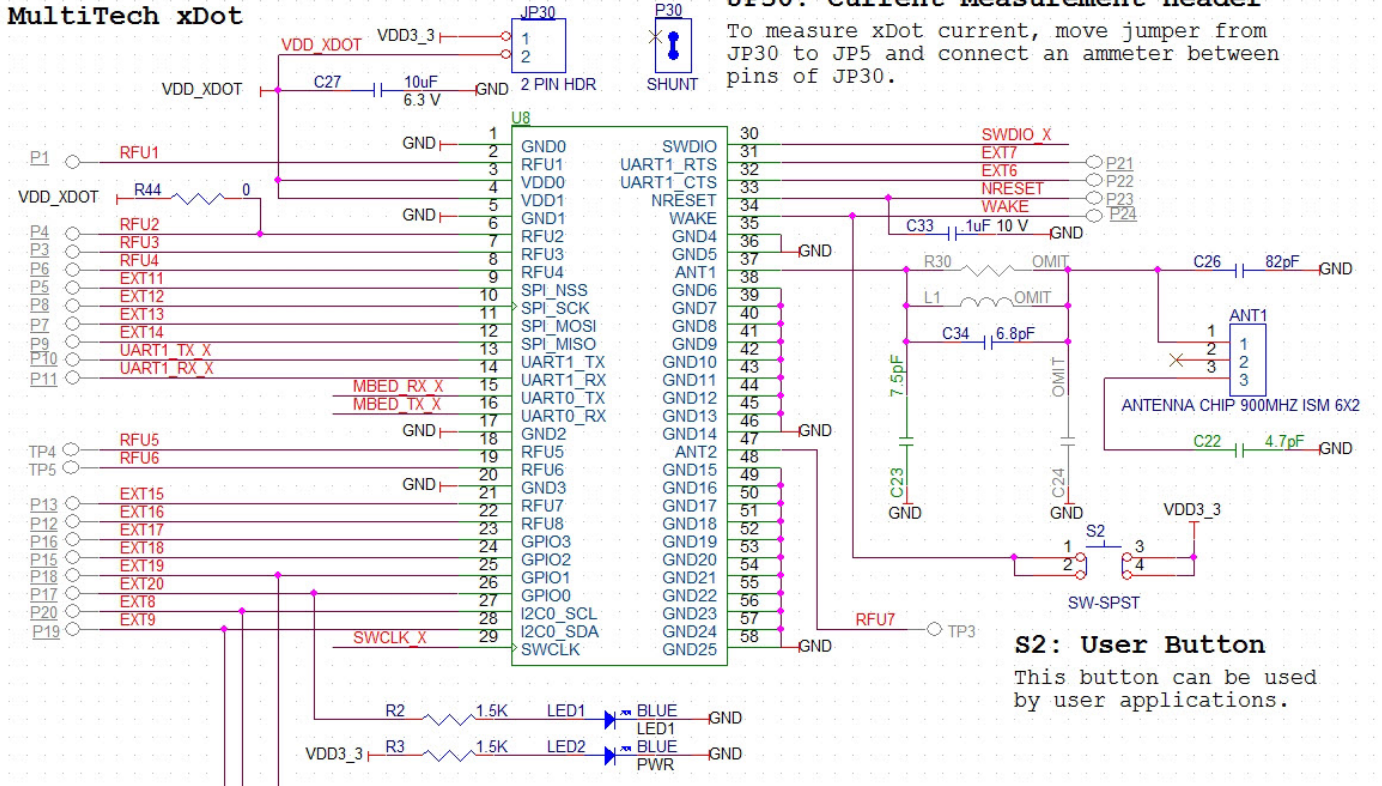

868

MultiTech xDot

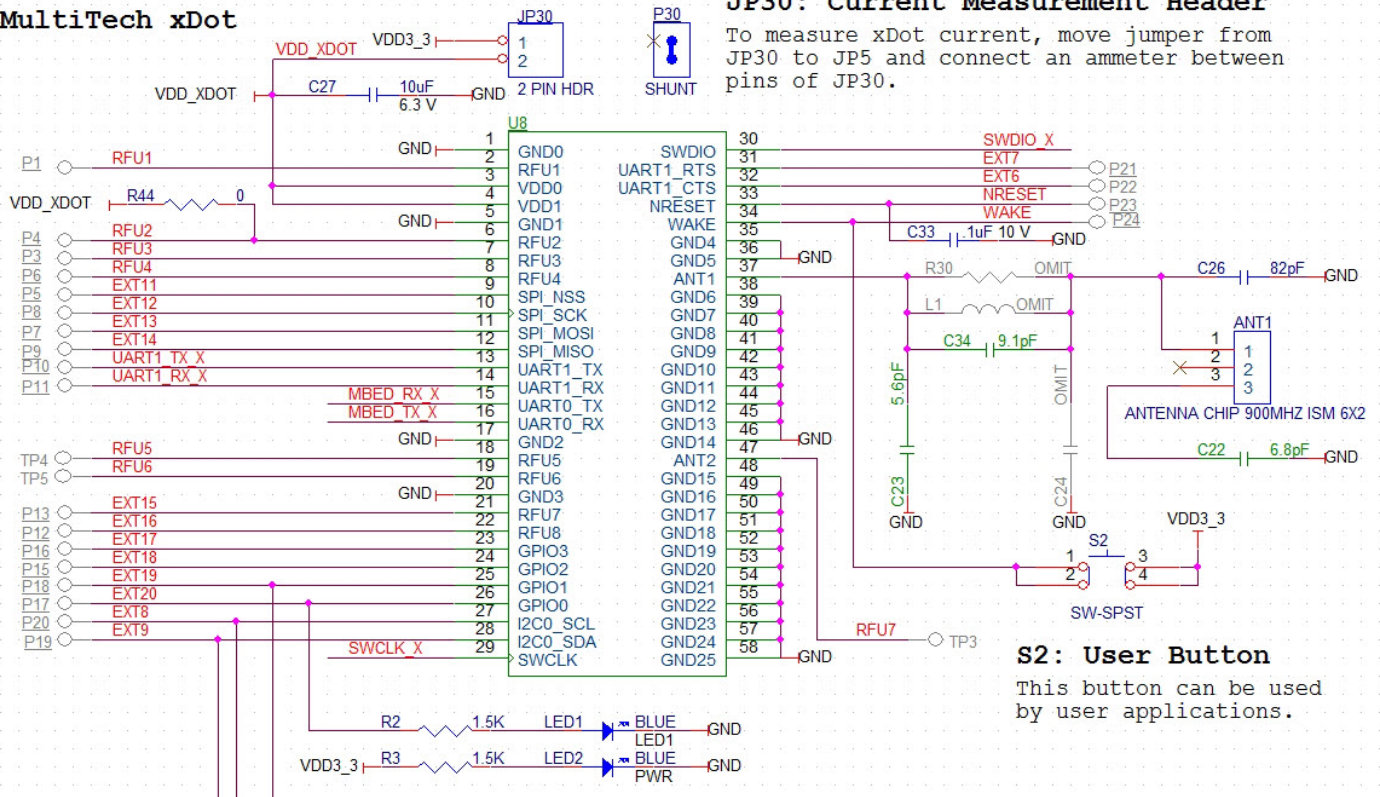

OEM Integration

FCC & IC Information to Consumers

The user manual for the consumer must contain the statements required by the following FCC and IC regulations: 47 C.F.R. 15.19(a)(3), 15.21, 15.105 and RSS-Gen Issue 4 Sections 8.3 and 8.4.

FCC Grant Notes

The OEM should follow all the grant notes listed below. Otherwise, further testing and device approvals may be necessary.

FCC Definitions

**Portable: (§2.1093)** — A portable device is defined as a transmitting device designed to be used so that the radiating structure(s) of the device is/are within 20 centimeters of the body of the user.

**Mobile: (§2.1091)** — A mobile device is defined as a transmitting device designed to be used in other than fixed locations and to generally be used in such a way that a separation distance of at least 20 centimeters is normally maintained between the transmitter’s radiating structure(s) and the body of the user or nearby persons.

**Actual content pending Grant:** *This device is a mobile device with respect to RF exposure compliance. The antenna(s) used for this transmitter must be installed to provide a separation distance of at least 20 cm from all persons, and must not be collocated or operate in conjunction with any other antenna or transmitter except in accordance with FCC multi-transmitter product guidelines. Installers and end-users must be provided with specific information required to satisfy RF exposure compliance for installations and final host devices. (See note under Grant Limitations.) Compliance of this device in all final host configurations is the responsibility of the Grantee.*

**Note:** Host design configurations constituting a device for portable use (<20 cm from human body) require separate FCC/IC approval.

## Host Labeling

The following statements are required to be on the host label:

- This device contains FCC ID: AU792U13A16858
- This device contains equipment certified under IC: 125A-0055

For labeling examples, see Cellular Approvals and Labeling Requirements.

## Chapter 6 – Safety Information

---

### Handling Precautions

To avoid damage due to the accumulation of static charge, use proper precautions when handling any cellular device. Although input protection circuitry has been incorporated into the devices to minimize the effect of static build-up, use proper precautions to avoid exposure to electronic discharge during handling and mounting the device.

### Radio Frequency (RF) Safety

Due to the possibility of radio frequency (RF) interference, it is important that you follow any special regulations regarding the use of radio equipment. Follow the safety advice given below.

- Operating your device close to other electronic equipment may cause interference if the equipment is inadequately protected. Observe any warning signs and manufacturers' recommendations.
- Different industries and businesses restrict the use of cellular devices. Respect restrictions on the use of radio equipment in fuel depots, chemical plants, or where blasting operations are in process. Follow restrictions for any environment where you operate the device.
- Do not place the antenna outdoors.
- Switch OFF your wireless device when in an aircraft. Using portable electronic devices in an aircraft may endanger aircraft operation, disrupt the cellular network, and is illegal. Failing to observe this restriction may lead to suspension or denial of cellular services to the offender, legal action, or both.
- Switch OFF your wireless device when around gasoline or diesel-fuel pumps and before filling your vehicle with fuel.
- Switch OFF your wireless device in hospitals and any other place where medical equipment may be in use.

### Sécurité relative aux appareils à radiofréquence (RF)

À cause du risque d'interférences de radiofréquence (RF), il est important de respecter toutes les réglementations spéciales relatives aux équipements radio. Suivez les conseils de sécurité ci-dessous.

- Utiliser l'appareil à proximité d'autres équipements électroniques peut causer des interférences si les équipements ne sont pas bien protégés. Respectez tous les panneaux d'avertissement et les recommandations du fabricant.
- Certains secteurs industriels et certaines entreprises limitent l'utilisation des appareils cellulaires. Respectez ces restrictions relatives aux équipements radio dans les dépôts de carburant, dans les usines de produits chimiques, ou dans les zones où des dynamitages sont en cours. Suivez les restrictions relatives à chaque type d'environnement où vous utiliserez l'appareil.
- Ne placez pas l'antenne en extérieur.
- Éteignez votre appareil sans fil dans les avions. L'utilisation d'appareils électroniques portables en avion est illégale: elle peut fortement perturber le fonctionnement de l'appareil et désactiver le réseau cellulaire. S'il ne respecte pas cette consigne, le responsable peut voir son accès aux services cellulaires suspendu ou interdit, peut être poursuivi en justice, ou les deux.
- Éteignez votre appareil sans fil à proximité des pompes à essence ou de diesel avant de remplir le réservoir de votre véhicule de carburant.

- Éteignez votre appareil sans fil dans les hôpitaux ou dans toutes les zones où des appareils médicaux sont susceptibles d'être utilisés.

## Interference with Pacemakers and Other Medical Devices

### Potential interference

Radio frequency energy (RF) from cellular devices can interact with some electronic devices. This is electromagnetic interference (EMI). The FDA helped develop a detailed test method to measure EMI of implanted cardiac pacemakers and defibrillators from cellular devices. This test method is part of the Association for the Advancement of Medical Instrumentation (AAMI) standard. This standard allows manufacturers to ensure that cardiac pacemakers and defibrillators are safe from cellular device EMI.

The FDA continues to monitor cellular devices for interactions with other medical devices. If harmful interference occurs, the FDA will assess the interference and work to resolve the problem.

### Precautions for pacemaker wearers

If EMI occurs, it could affect a pacemaker in one of three ways:

- Stop the pacemaker from delivering the stimulating pulses that regulate the heart's rhythm.
- Cause the pacemaker to deliver the pulses irregularly.
- Cause the pacemaker to ignore the heart's own rhythm and deliver pulses at a fixed rate.

Based on current research, cellular devices do not pose a significant health problem for most pacemaker wearers. However, people with pacemakers may want to take simple precautions to be sure that their device doesn't cause a problem.

- Keep the device on the opposite side of the body from the pacemaker to add extra distance between the pacemaker and the device.
- Avoid placing a turned-on device next to the pacemaker (for example, don't carry the device in a shirt or jacket pocket directly over the pacemaker).

## Device Maintenance

Do not attempt to disassemble the device. There are no user serviceable parts inside.

When maintaining your device:

- Do not misuse the device. Follow instructions on proper operation and only use as intended. Misuse could make the device inoperable, damage the device and/or other equipment, or harm users.
- Do not apply excessive pressure or place unnecessary weight on the device. This could result in damage to the device or harm to users.
- Do not use this device in explosive or hazardous environments unless the model is specifically approved for such use. The device may cause sparks. Sparks in explosive areas could cause explosion or fire and may result in property damage, severe injury, and/or death.
- Do not expose your device to any extreme environment where the temperature or humidity is high. Such exposure could result in damage to the device or fire. Refer to the device specifications regarding recommended operating temperature and humidity.
- Do not expose the device to water, rain, or spilled beverages. Unless the device is IP67 rated, it is not waterproof. Exposure to liquids could result in damage to the device.

- Do not place the device alongside computer discs, credit or travel cards, or other magnetic media. The information contained on discs or cards may be affected by the device.
- Using accessories, such as antennas, that MultiTech has not authorized or that are not compliant with MultiTech's accessory specifications may invalidate the warranty.

If the device is not working properly, contact MultiTech Technical Support.

## User Responsibility

Respect all local regulations for operating your wireless device. Use the security features to block unauthorized use and theft.

## Chapter 7 – Regulatory Information

### EMC, Safety, and Radio Equipment Directive (RED) Compliance



The CE mark is affixed to this product to confirm compliance with the following European Community Directives:

- Council Directive 2011/65/EU on the restriction of the use of certain hazardous substances in electrical and electronic equipment;
- and
- Council Directive 2014/53/EU on radio equipment and telecommunications terminal equipment and the mutual recognition of their conformity.

MultiTech declares that this device is in compliance with the essential requirements and other relevant provisions of Directive 2014/53/EU. The declaration of conformity may be requested at <https://support.multitech.com>.

### 47 CFR Part 15 Regulation Class B Devices

This equipment has been tested and found to comply with the limits for a Class B digital device, pursuant to part 15 of the FCC Rules. These limits are designed to provide reasonable protection against harmful interference in a residential installation. This equipment generates, uses, and can radiate radio frequency energy and, if not installed and used in accordance with the instructions, may cause harmful interference to radio communications. However, there is no guarantee that interference will not occur in a particular installation. If this equipment does cause harmful interference to radio or television reception, which can be determined by turning the equipment off and on, the user is encouraged to try to correct the interference by one or more of the following measures:

- Reorient or relocate the receiving antenna.
- Increase the separation between the equipment and receiver.
- Connect the equipment into an outlet on a circuit different from that to which the receiver is connected.
- Consult the dealer or an experienced radio/TV technician for help.

**Warning:** Changes or modifications to this unit not expressly approved by the party responsible for compliance could void the user's authority to operate the equipment.

### FCC Interference Notice

Per FCC 15.19(a)(3) and (a)(4) This device complies with part 15 of the FCC Rules. Operation is subject to the following two conditions: (1) This device may not cause harmful interference, and (2) this device must accept any interference received, including interference that may cause undesired operation.

### FCC Notice

Per FCC 15.19(a)(3) and (a)(4) This device complies with part 15 of the FCC Rules. Operation is subject to the following two conditions: (1) This device may not cause harmful interference, and (2) this device must accept any interference received, including interference that may cause undesired operation.

This device is open development based product that contains a sub GHz radio technology. MultiTech has certified for compliance with US and Foreign compliance bodies including FCC, R&TTE and others. (e.g. FCC 15.247:2015 & IC RSS-210:2010)

xDot products are open development based products that contain a sub ghz radio technology. MultiTech has certified for compliance with US and Foreign compliance bodies including FCC, R&TTE and others. (e.g. FCC 15.247:2015 & IC RSS 247:2015)

MultiTech provides software code meant to operate the radio to a level that maintains compliance with the operating modes under which these radio devices were certified. To ensure this level of compliance, the software code is provided in binary form only. Users are prohibited from making any changes that affect the operation of the radio performance. Accessing or controlling the radio through any means other than the provided binary software will require the user to obtain their own intentional radiator license from the certification body governing their locality, as all pre-certification provided with Conduit Base Station IP67 xDot will have been made invalid.

## Industry Canada Class B Notice

This Class B digital apparatus meets all requirements of the Canadian Interference-Causing Equipment Regulations.

Cet appareil numérique de la classe B respecte toutes les exigences du Règlement Canadien sur le matériel brouilleur.

This device complies with Industry Canada license-exempt RSS standard(s). The operation is permitted for the following two conditions:

1. the device may not cause interference, and
2. this device must accept any interference, including interference that may cause undesired operation of the device.

Le présent appareil est conforme aux CNR d'Industrie Canada applicables aux appareils radio exempts de licence. L'exploitation est autorisée aux deux conditions suivantes:

1. l'appareil ne doit pas produire de brouillage, et
2. l'appareil doit accepter tout brouillage radioélectrique subi, même si le brouillage est susceptible d'en compromettre le fonctionnement.

## Chapter 8 – Environmental Notices

### Waste Electrical and Electronic Equipment Statement

**Note:** This statement may be used in documentation for your final product applications.

#### WEEE Directive

The WEEE Directive places an obligation on EU-based manufacturers, distributors, retailers, and importers to take-back electronics products at the end of their useful life. A sister directive, ROHS (Restriction of Hazardous Substances) complements the WEEE Directive by banning the presence of specific hazardous substances in the products at the design phase. The WEEE Directive covers all MultiTech products imported into the EU as of August 13, 2005. EU-based manufacturers, distributors, retailers and importers are obliged to finance the costs of recovery from municipal collection points, reuse, and recycling of specified percentages per the WEEE requirements.

#### Instructions for Disposal of WEEE by Users in the European Union

The symbol shown below is on the product or on its packaging, which indicates that this product must not be disposed of with other waste. Instead, it is the user's responsibility to dispose of their waste equipment by handing it over to a designated collection point for the recycling of waste electrical and electronic equipment. The separate collection and recycling of your waste equipment at the time of disposal will help to conserve natural resources and ensure that it is recycled in a manner that protects human health and the environment. For more information about where you can drop off your waste equipment for recycling, please contact your local city office, your household waste disposal service or where you purchased the product.

July, 2005



### REACH Statement

#### Registration of Substances

**Multi-Tech Systems, Inc.** confirms that none of its products or packaging contain any of the Substances of Very High Concern (SVHC) on the REACH Candidate List, in a concentration above the 0.1% by weight allowable limit

The latest **197** substances restricted per the REACH Regulation were **last updated January 2019**. Refer to the following for the most current candidate list of substances: <http://echa.europa.eu/candidate-list-table>.

### Restriction of the Use of Hazardous Substances (RoHS)

**Multi-Tech Systems, Inc.**

**Certificate of Compliance**

**2015/863**

Multi-Tech Systems, Inc. confirms that its embedded products comply with the chemical concentration limitations set forth in the directive 2015/863 of the European Parliament (Restriction of the use of certain Hazardous Substances in electrical and electronic equipment - RoHS).

These MultiTech products do not contain the following banned chemicals<sup>1</sup>:

- Lead, [Pb] < 1000 PPM
- Mercury, [Hg] < 100 PPM
- Cadmium, [Cd] < 100 PPM
- Hexavalent Chromium, [Cr+6] < 1000 PPM
- Polybrominated Biphenyl, [PBB] < 1000 PPM
- Polybrominated Diphenyl Ethers, [PBDE] < 1000 PPM
- Bis(2-Ethylhexyl) phthalate (DEHP): < 1000 ppm
- Benzyl butyl phthalate (BBP): < 1000 ppm
- Dibutyl phthalate (DBP): < 1000 ppm
- Diisobutyl phthalate (DIBP): < 1000 ppm

Environmental considerations:

- Moisture Sensitivity Level (MSL) =1
- Maximum Soldering temperature = 260C (in SMT reflow oven)

<sup>1</sup>Lead usage in some components is exempted by the following RoHS annex, therefore higher lead concentration would be found in some modules (>1000 PPM);

- Resistors containing lead in a glass or ceramic matrix compound.

## Information on HS/TS Substances According to Chinese Standards

In accordance with China's Administrative Measures on the Control of Pollution Caused by Electronic Information Products (EIP) # 39, also known as China RoHS, the following information is provided regarding the names and concentration levels of Toxic Substances (TS) or Hazardous Substances (HS) which may be contained in Multi-Tech Systems Inc. products relative to the EIP standards set by China's Ministry of Information Industry (MII).

### Hazardous/Toxic Substance/Elements

Name of the Component	Lead (PB)	Mercury (Hg)	Cadmium (CD)	Hexavalent Chromium (CR6+)	Polybrominated Biphenyl (PBB)	Polybrominated Diphenyl Ether (PBDE)
Printed Circuit Boards	O	O	O	O	O	O
Resistors	X	O	O	O	O	O
Capacitors	X	O	O	O	O	O
Ferrite Beads	O	O	O	O	O	O
Relays/Opticals	O	O	O	O	O	O
ICs	O	O	O	O	O	O
Diodes/ Transistors	O	O	O	O	O	O
Oscillators and Crystals	X	O	O	O	O	O
Regulator	O	O	O	O	O	O
Voltage Sensor	O	O	O	O	O	O
Transformer	O	O	O	O	O	O
Speaker	O	O	O	O	O	O
Connectors	O	O	O	O	O	O
LEDs	O	O	O	O	O	O
Screws, Nuts, and other Hardware	X	O	O	O	O	O
AC-DC Power Supplies	O	O	O	O	O	O
Software /Documentation CDs	O	O	O	O	O	O
Booklets and Paperwork	O	O	O	O	O	O
Chassis	O	O	O	O	O	O

**X** Represents that the concentration of such hazardous/toxic substance in all the units of homogeneous material of such component is higher than the SJ/Txxx-2006 Requirements for Concentration Limits.

**O** Represents that no such substances are used or that the concentration is within the aforementioned limits.

## Information on HS/TS Substances According to Chinese Standards (in Chinese)

### 依照中国标准的有毒有害物质信息

根据中华人民共和国信息产业部 (MII) 制定的电子信息产品 (EIP) 标准—中华人民共和国《电子信息产品污染控制管理办法》(第 39 号), 也称作中国 RoHS, 下表列出了 Multi-Tech Systems, Inc. 产品中可能含有的有毒物质 (TS) 或有害物质 (HS) 的名称及含量水平方面的信息。

### 有害/有毒物质/元素

成分名称	铅 (PB)	汞 (Hg)	镉 (CD)	六价铬 (CR6+)	多溴联苯 (PBB)	多溴二苯醚 (PBDE)
印刷电路板	O	O	O	O	O	O
电阻器	X	O	O	O	O	O
电容器	X	O	O	O	O	O
铁氧体磁环	O	O	O	O	O	O
继电器/光学部件	O	O	O	O	O	O
ICs	O	O	O	O	O	O
二极管/晶体管	O	O	O	O	O	O
振荡器和晶振	X	O	O	O	O	O
调节器	O	O	O	O	O	O
电压传感器	O	O	O	O	O	O
变压器	O	O	O	O	O	O
扬声器	O	O	O	O	O	O
连接器	O	O	O	O	O	O
LEDs	O	O	O	O	O	O
螺丝、螺母以及其它五金件	X	O	O	O	O	O
交流-直流电源	O	O	O	O	O	O
软件/文档 CD	O	O	O	O	O	O
手册和纸页	O	O	O	O	O	O
底盘	O	O	O	O	O	O

X 表示所有使用类似材料的设备中有害/有毒物质的含量水平高于 SJ/Txxx-2006 限量要求。

O 表示不含该物质或者该物质的含量水平在上述限量要求之内。

# Chapter 9 – Labels

## Label Examples

**Note:** Actual labels vary depending on the regulatory approval markings and content.

This device complies with part 15 of the FCC Rules. Operation is subject to the following two conditions: (1) This device may not cause harmful interference, and (2) this device must accept any interference received, including interference that may cause undesired operation.

The label shown is not the actual size.

- 1 - MultiTech Model Identification.
- 2 - MultiTech Ordering Part Number.
- 3 - Device Node Number.

Example xDot Device Label



Example Developer Board Device Label



## Chapter 10 – Developer Kit Overview

---

### xDot Developer Kit

The xDot developer kit comes with an xDot already mounted on the developer board. Simply plug the developer kit into a USB port on your computer to test, program, and evaluate your application.

### Developer Kit Package Contents

Your Developer Kit (MTMDK-NX-XDOT-xx) includes the following:

Developer Board	1 - xDot Developer Board with xDot
Customer Notices	Quick Start

### Firmware Updates

Before starting your project development, make sure you have the latest firmware for the Developer Kit and xDot. Go to the xDot mbed page for firmware. <https://developer.mbed.org/platforms/MTS-xDot-L151CC/>

### Programming Devices in Production

Consult [developer kit schematics](#) for programming options.

# xDot Developer Kit Mechanical Drawings

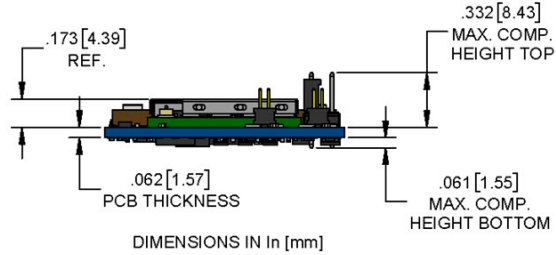
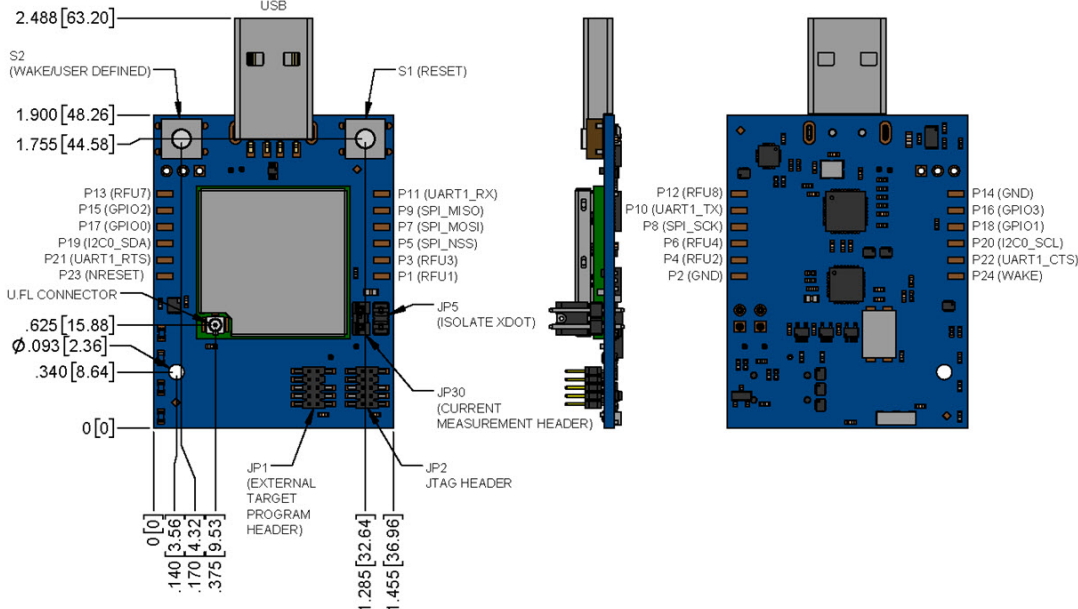
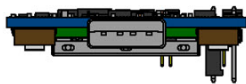
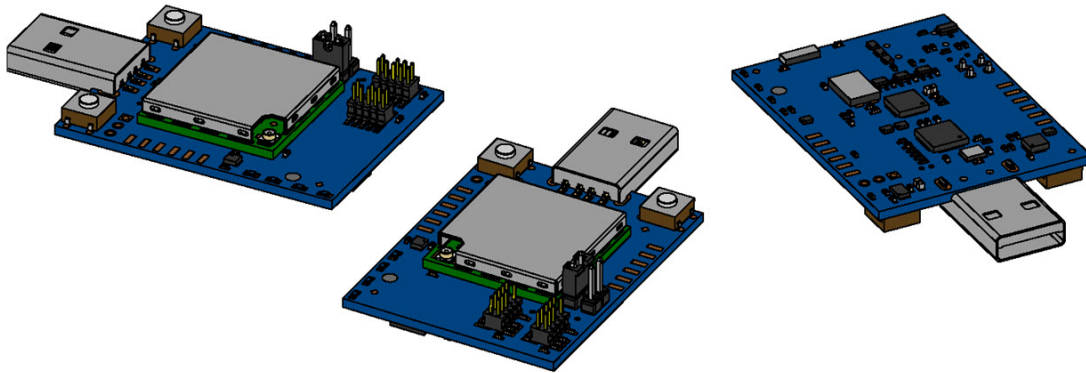

**Note:** The Reset and Wake buttons reset and wake the xDot processor.

## Micro Developer Board LEDs

LED	Description
LED1	User-definable LED.
LED3/SDA	Programming Status.
LED2/PWR	Power, blue light when the board has power.
LED4/PROXY	LED for the proximity sensor, which is next to it (labeled U14 on the top assembly diagram).

# Chapter 11 – Developer Board Schematics

## Assembly Diagrams and Schematics

### Assembly Diagrams

Top

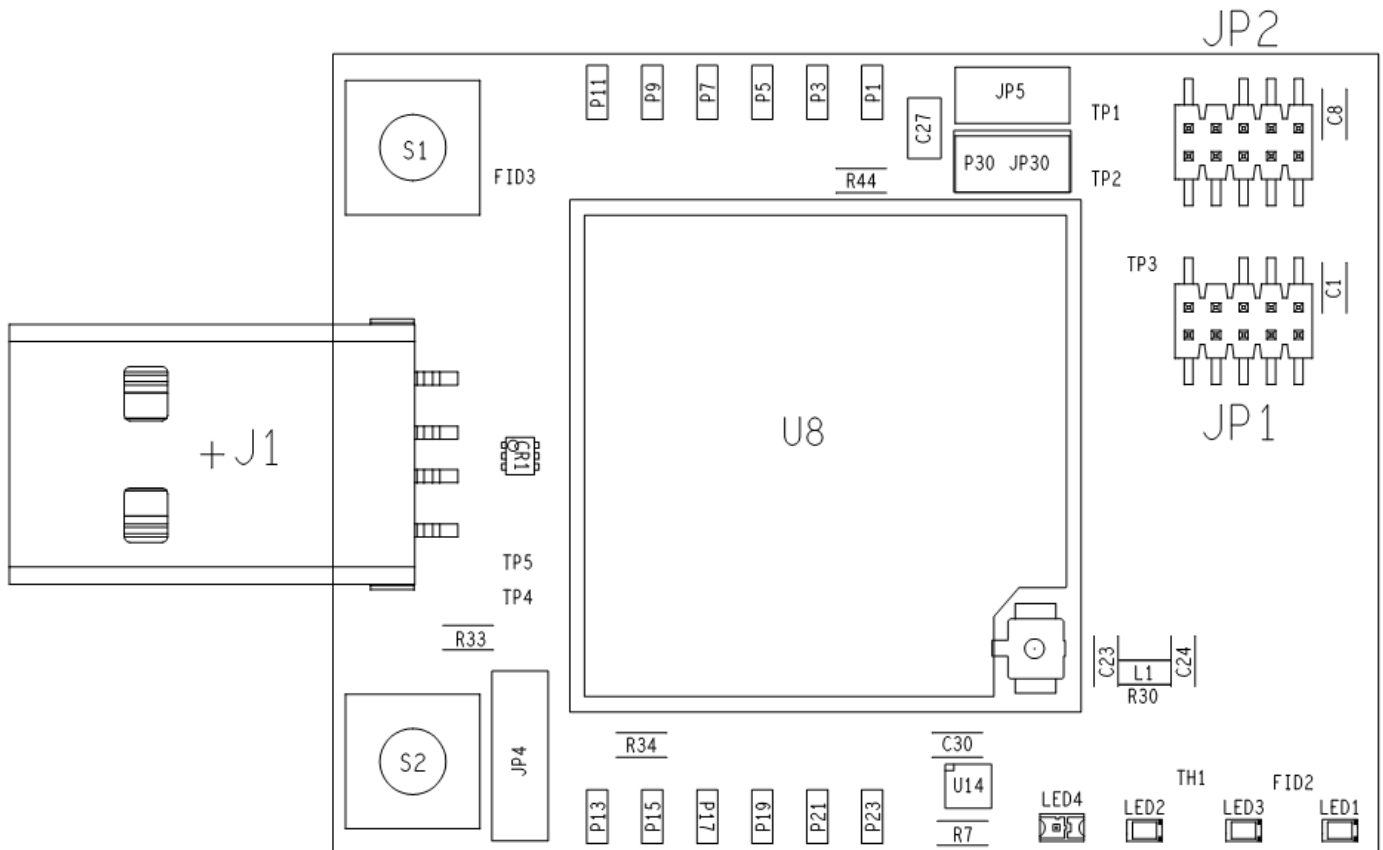

R30 SITS ON L1  
C34 SITS ON L1

Bottom

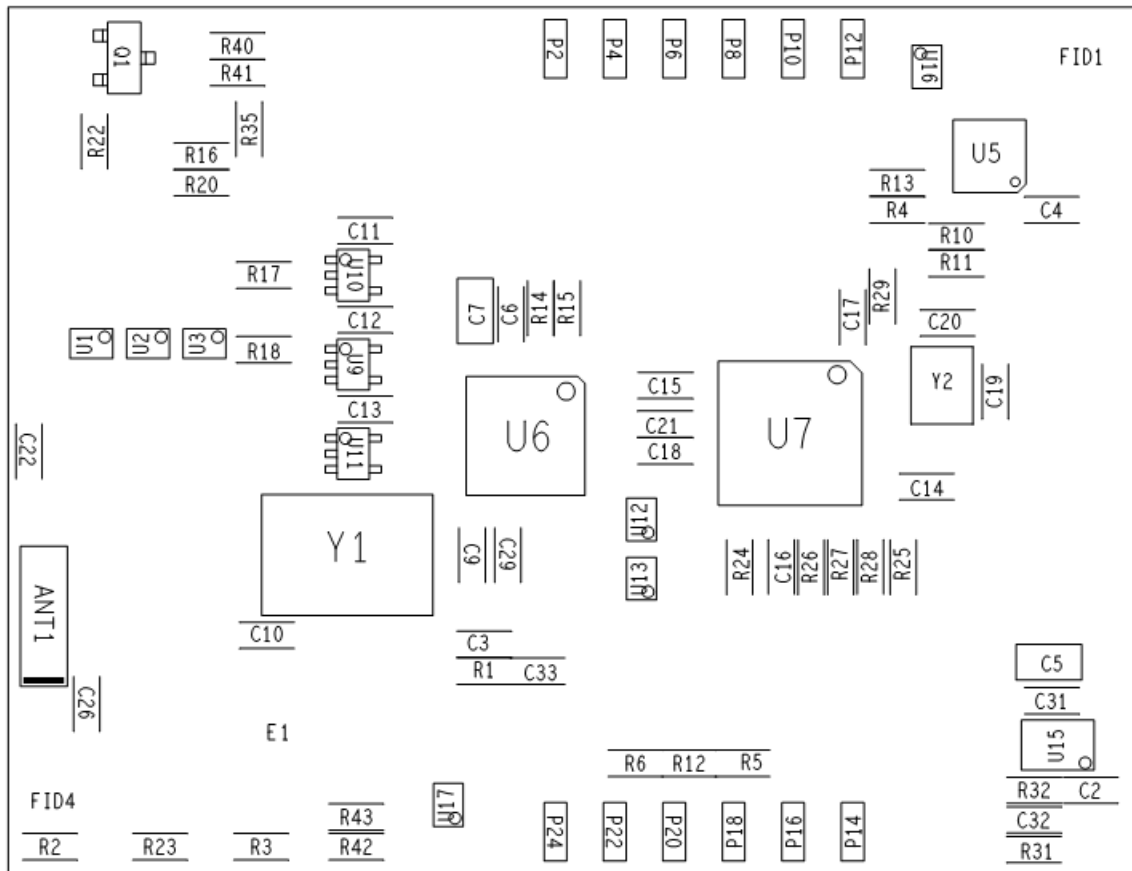

Schematics

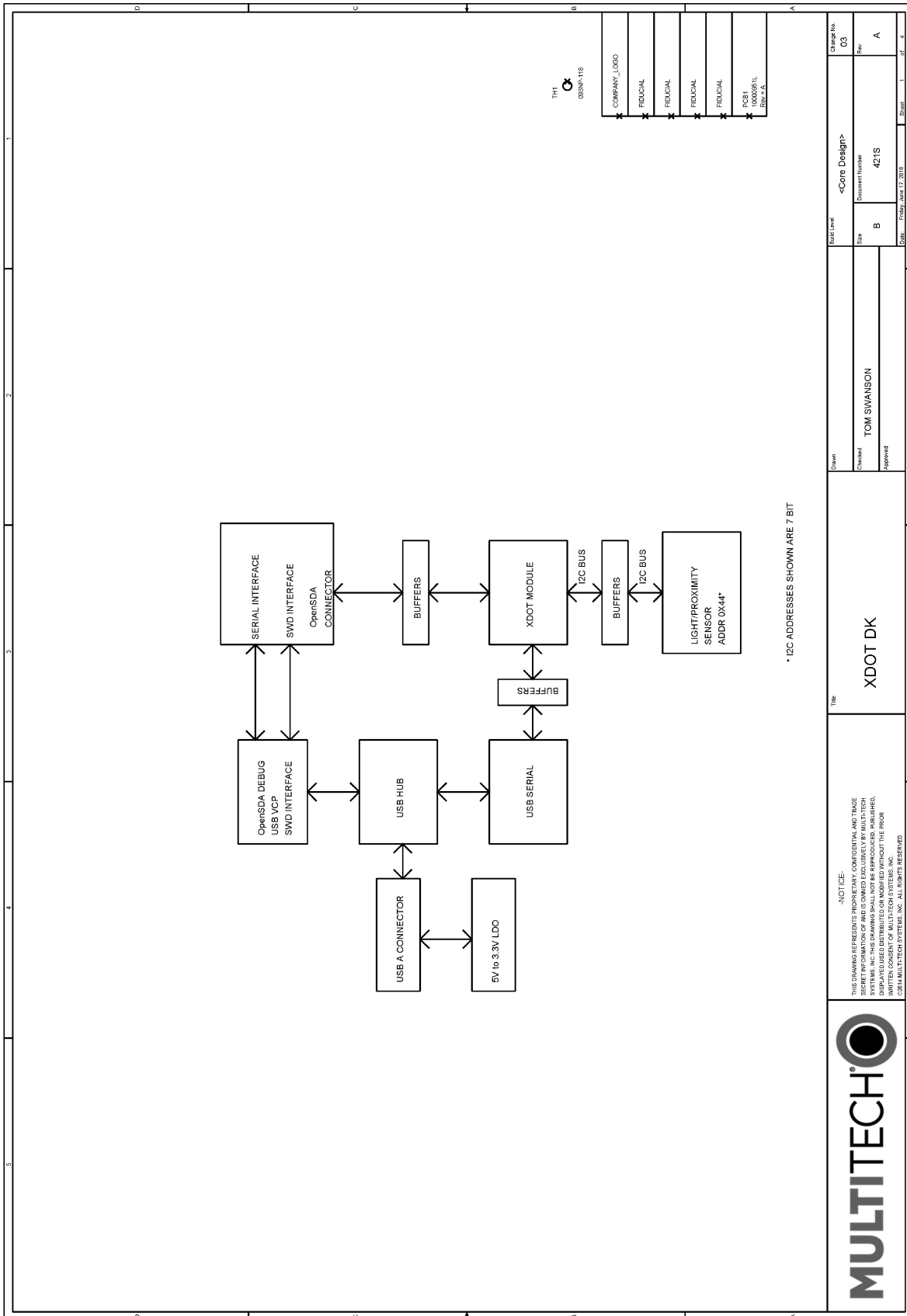

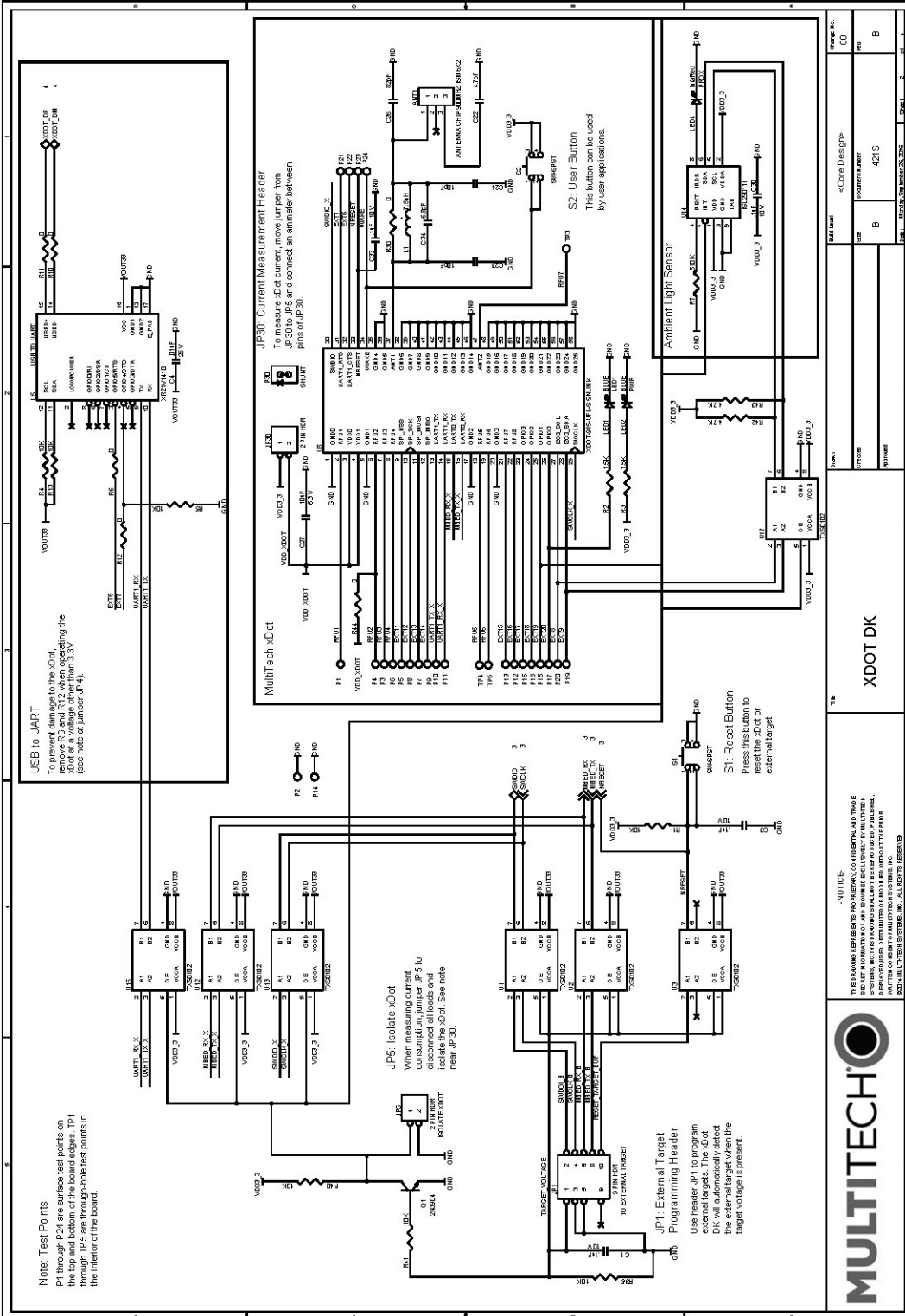



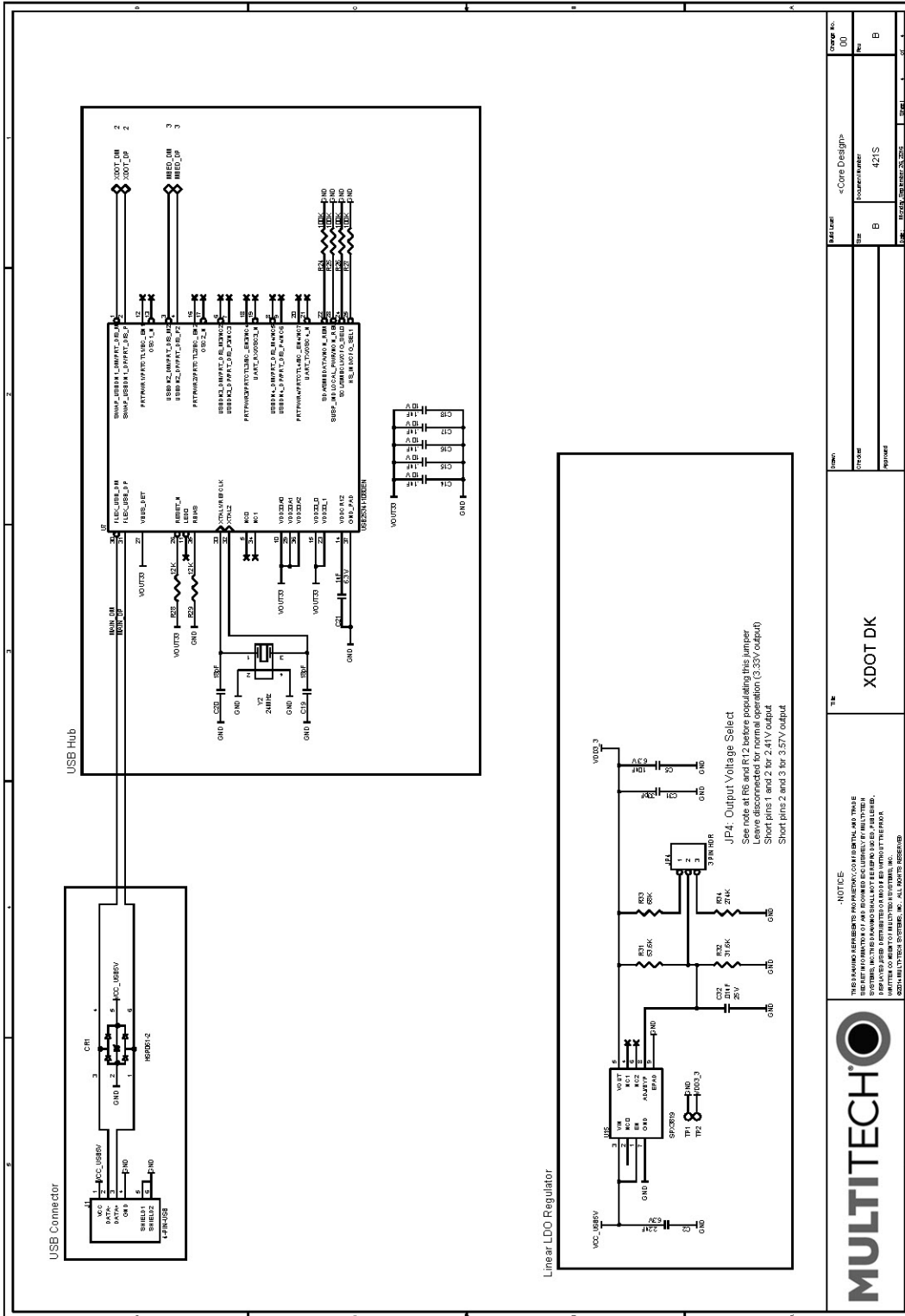

NOTICE: THESE DRAWINGS REPRESENT PRELIMINARY DESIGN. MULTITECH AND THESE REPRESENTATIONS OF AND SHOULD BE CONSIDERED AS PRELIMINARY. MULTITECH AND THESE REPRESENTATIONS OF AND SHOULD BE CONSIDERED AS PRELIMINARY. MULTITECH AND THESE REPRESENTATIONS OF AND SHOULD BE CONSIDERED AS PRELIMINARY.

XDOT DK

Part List	<Core Design>	Change No.	00
Rev	B	Rev	B
Rev	421S	Rev	B
Rev	421S	Rev	B

# Chapter 12 – Design Considerations

## Noise Suppression Design

Adhere to engineering noise-suppression practices when designing a printed circuit board (PCB). Noise suppression is essential to the proper operation and performance of the modem and surrounding equipment.

Any OEM board design must consider both on-board and off-board generated noise that can affect digital signal processing. Both on-board and off-board generated noise that is coupled on-board can affect interface signal levels and quality. Noise in frequency ranges that affect modem performance is of particular concern.

On-board generated electromagnetic interference (EMI) noise that can be radiated or conducted off-board is equally important. This type of noise can affect the operation of surrounding equipment. Most local government agencies have certification requirements that must be met for use in specific environments.

Proper PC board layout (component placement, signal routing, trace thickness and geometry, and so on) component selection (composition, value, and tolerance), interface connections, and shielding are required for the board design to achieve desired modem performance and to attain EMI certification.

Other aspects of proper noise-suppression engineering practices are beyond the scope of this guide. Consult noise suppression techniques described in technical publications and journals, electronics and electrical engineering text books, and component supplier application notes.

## PC Board Layout Guideline

In a 4-layer design, provide adequate ground plane covering the entire board. In 4-layer designs, power and ground are typically on the inner layers. Ensure that all power and ground traces are 0.05 inches wide.

Use spacers to hold the device vertically in place during the wave solder process. For an xDot the recommended landing pad size is the same as the xDot's pad size, 0.28 in (0.71 cm).

## Electromagnetic Interference

The following guidelines are offered specifically to help minimize EMI generation. Some of these guidelines are the same as, or similar to, the general guidelines. To minimize the contribution of device-based design to EMI, you must understand the major sources of EMI and how to reduce them to acceptable levels.

- Keep traces carrying high frequency signals as short as possible.
- Provide a good ground plane or grid. In some cases, a multilayer board may be required with full layers for ground and power distribution.
- Decouple power from ground with decoupling capacitors as close to the device's power pins as possible.
- Eliminate ground loops, which are unexpected current return paths to the power source and ground.
- Decouple the telephone line cables at the telephone line jacks. Typically, use a combination of series inductors, common mode chokes, and shunt capacitors. Methods to decouple telephone lines are similar to decoupling power lines; however, telephone line decoupling may be more difficult and deserves additional attention. A commonly used design aid is to place footprints for these components and populate as necessary during performance/EMI testing and certification.
- Decouple the power cord at the power cord interface with decoupling capacitors. Methods to decouple power lines are similar to decoupling telephone lines.

- Locate high frequency circuits in a separate area to minimize capacitive coupling to other circuits.
- Locate cables and connectors to avoid coupling from high frequency circuits.
- Lay out the highest frequency signal traces next to the ground grid.
- If using a multilayer board design, make no cuts in the ground or power planes and be sure the ground plane covers all traces.
- Minimize the number of through-hole connections on traces carrying high frequency signals.
- Avoid right angle turns on high frequency traces. Forty-five degree corners are good; however, radius turns are better.
- On 2-layer boards with no ground grid, provide a shadow ground trace on the opposite side of the board to traces carrying high frequency signals. This will be effective as a high frequency ground return if it is three times the width of the signal traces.
- Distribute high frequency signals continuously on a single trace rather than several traces radiating from one point.

## Electrostatic Discharge Control

Handle all electronic devices with precautions to avoid damage due to the static charge accumulation.

See the ANSI/ESD Association Standard (ANSI/ESD S20.20-1999) – a document “for the Development of an Electrostatic Discharge Control for Protection of Electrical and Electronic Parts, Assemblies and Equipment.” This document covers ESD Control Program Administrative Requirements, ESD Training, ESD Control Program Plan Technical Requirements (grounding/bonding systems, personnel grooming, protected areas, packaging, marking, equipment, and handling), and Sensitivity Testing.

MultiTech strives to follow these recommendations. Input protection circuitry is incorporated in MultiTech devices to minimize the effect of static buildup. Take precautions to avoid exposure to electrostatic discharge during handling.

MultiTech uses and recommends that others use anti-static boxes that create a faraday cage (packaging designed to exclude electromagnetic fields). MultiTech recommends that you use our packaging when returning a product and when you ship your products to your customers.

# Chapter 13 – Mounting xDots and Programming External Targets

## Mounting the Device on Your Board

A footprint diagram is included on the [xDot Mechanical Diagram](#).

## Solder Profile

Solder Paste: AIM M8 Lead-Free

**Note:** Calculate slope over 120 seconds

Name	Low Limit	High Limit	Units
Max Rising Slope (Target=1.0)	0	2	Degrees/Second
Max Falling Slope	-2	-0.1	Degrees/Second
Soak Time 150-170C	15	45	Seconds
Peak Temperature	235	250	Degrees Celsius
Total Time Above 218C	30	90	Seconds

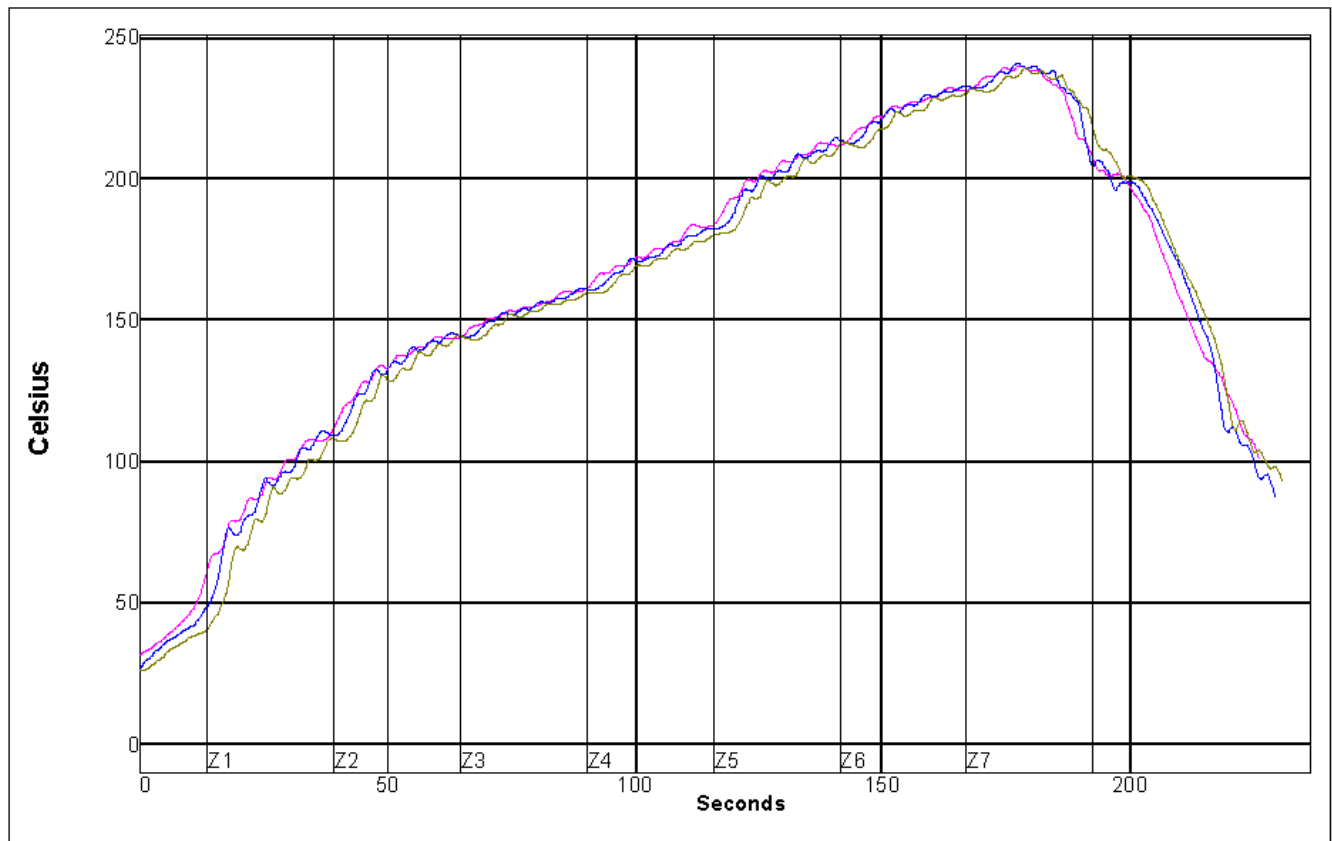

## Setpoints (Celsius)

Zone	1	2	3	4	5	6	7
<b>Top</b>	130	160	170	190	230	245	255
<b>Bottom</b>	130	160	170	190	230	245	255
<b>Conveyer Speed</b>	32.0 inch/minute						

TC	Position	Max Rising Slope		Max Falling Slope		Soak Time 150-170C		Peak Temp		Total Time /218C	
		Slope	PWI	Slope	PWI	Time	PWI	Temp	PWI	Time	PWI
1	<TC2>	1.38	38%	-0.63	45%	28.82	-8%	240.22	-30%	43.61	-55%
2	<TC3>	1.38	38%	-0.75	32%	26.75	-22%	241.21	-17%	43.66	-54%
3	<TC4>	1.38	38%	-0.70	36%	29.47	-4%	239.56	-39%	43.29	-56%
Delta		0.00		0.12		2.72		1.65		0.37	

## xDot Packing

xDots ship on 20 piece trays, which you can use for pick and place handling.

**Warning:** Maximum temperature for these trays is 65° C.

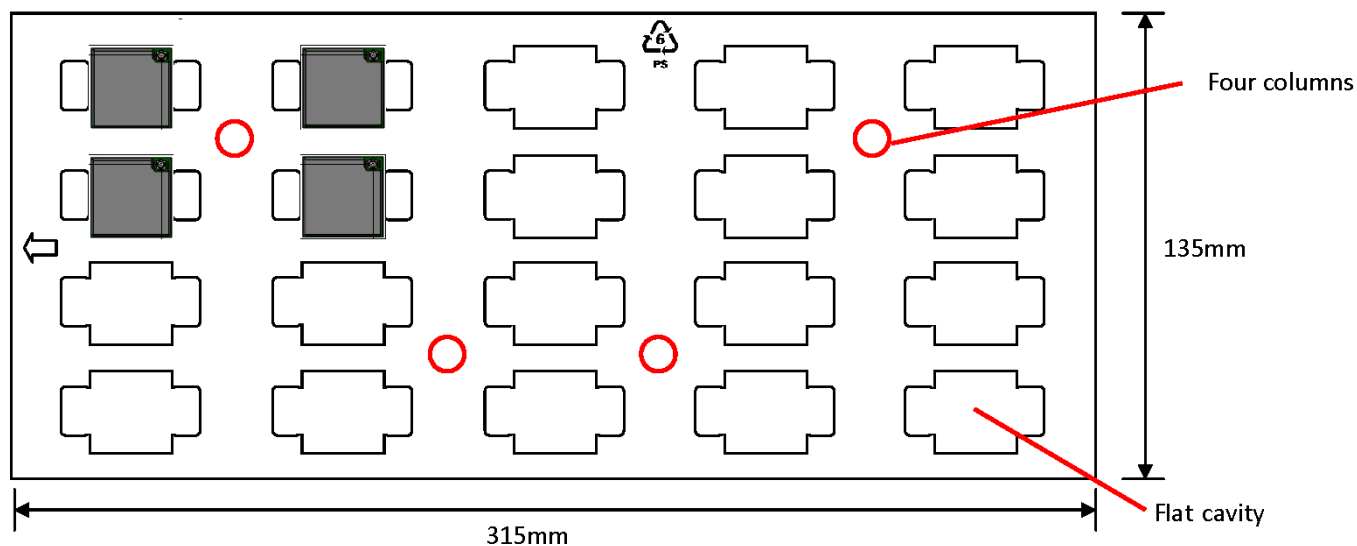

## In-System Programming of xDot

You can use the xDot developer board to in-system program an xDot on your custom board. To do this, your board must implement a 9-pin header for the JTAG SWD and Mbed debug serial signals. See the example schematic in this topic.

When the xDot developer board detects a target voltage on Pin 1 of JP1, it redirects the Mbed programming interface to the external xDot. You can use the Mbed programming environment as normal to program and debug the external xDot.



## JTAG/SWD Connector

The developer board uses an unshrouded 9-pin header.

Suitable connector headers include:

- Harwin: M50-3500542
- Mouser: 855-M50-3500542
- Samtec shrouded header: FTSH-105-01-F-D-K

The Samtec FTSH-105 header dimensions are 0.25"x 0.188" (6.35mm x 4.78mm).

Ensure that you connect your cable correctly, typically by matching the "1" marked on the board to the cable's red stripe.

## Chapter 14 – Appendix A Release Note Archive

### What's New in Firmware Version 3.0

The new release includes the following changes:

- LoRaWAN 1.0.2 Support
- Listen Before Talk
- Separate Channel Plans

For more information on using these features, visit <https://developer.mbed.org/platforms/MTS-xDot-L151CC/>.

#### LoRaWAN 1.0.2 Support

Adds AS923, extending support to Brunei, Cambodia, Hong Kong, Indonesia, Japan, Laos, New Zealand, Singapore, South Korea, Taiwan, Thailand, and Vietnam.

Adds KR920, extending support to South Korea.

#### Listen Before Talk

Listen before talk (LBT) is required in Japan and South Korea. This feature is automatically configured by the channel plan.

- For Japan, the AS923 has LBT enabled by default.
- For all other AS923 countries, LBT is disabled by default.
- For South Korea, KR920 has LBT enabled by default.

#### Separate Channel Plans

Select a channel plan at compile time to integrate the channel plan with the firmware.

### What's New in Firmware Version 3.1

The new release includes the following changes:

- xDot Bootloader
- Power Optimization
- Other Enhancements

#### xDot Bootloader

The xDot bootloader allows firmware upgrades via ymodem over either the command or debug serial ports. For details, refer to [Updating Firmware Using the xDot Bootloader](#).

#### Power Optimization

To reduce power consumption during Class A transactions, Version 3.1 firmware includes a new auto sleep feature. When enabled, the microcontroller automatically goes into a stop sleep mode after an uplink transmit ends and in between two receive windows. In the stop sleep mode, RAM and register contents are retained, but all peripheral clocks are gated, so timers will not count during these intervals. Refer to the microcontroller datasheet for information regarding microcontroller sleep mode states.

New AT Command: +AS - Auto Sleep

## Other Enhancements

- Adaptive Data Rate (ADR) is now enabled by default.
- Public Network command, +PN, has been updated to include an MTS network in addition to the LoRaWAN public or private network options. This includes changes to parameter values. Refer to the +PN command in [S000643 DOT Series AT Command Reference Guide](#) for details.

*For an archive of release notes, go to Appendix A.*

# Index

schematics	
Developer Board .....	55
<b>A</b>	
antenna .....	31 32
developer board .....	34
antenna design guidelines .....	37
assembly diagrams	
Developer Board .....	55
AT command	
port .....	11
<b>B</b>	
battery draw down .....	22
baud rate .....	28
board components	
Micro Developer Board .....	54
bootloader .....	12
build options .....	10
<b>C</b>	
cable	
coaxial .....	33
certifications .....	15
Chinese hazardous substances	
Chinese version .....	50
English version .....	49
Class B .....	45
Industry Canada .....	46
COM ports .....	11
Conduit .....	8
<b>D</b>	
data bits .....	28
debug port .....	11
design guidelines	
antenna .....	37
device	
maintenance .....	43
dimensions .....	14
documentation .....	8
<b>E</b>	
electrical characteristics .....	22
electromagnetic interference .....	61
electrostatic discharge .....	62
EMI .....	61
ESD .....	62
EUI .....	9
external targets .....	64
<b>F</b>	
FCC	
grant notes .....	40
FCC Notice	
Class B .....	45
firmware update .....	12
flow control .....	28
<b>G</b>	
ground plane .....	61
<b>H</b>	
handling precautions due to ESD .....	62
hazardous substances .....	47
host labeling .....	40
<b>I</b>	
Industry Canada	
Class B .....	46
interférence des radiofréquences .....	42
<b>J</b>	
JTAG connector .....	66
<b>K</b>	
KDB 447498 Section 8 .....	40
<b>L</b>	
labeling	

host .....	40	receive sensitivity.....	15
labels .....	51	related products.....	8
Linux .....	11	reset .....	30
LoRa		ribbon cable .....	64
range.....	28	RoHS.....	47
		RSMA-to-UFL cable .....	33
<b>M</b>			
Mac .....	11	<b>S</b>	
maintenance .....	43	safety	
mbed .....	8	RF interference .....	42
mechanical drawings.....	14	safety standards.....	61
Micro Developer Board.....	53	serial settings .....	28
MTAC-LORA.....	8	solder profile.....	63
MTCDT.....	8	specifications.....	15
MultiConnect .....	8	static.....	42
		stop bits.....	28
<b>N</b>		sécurité	
network, connecting .....	9	interférences RF.....	42
noise suppression.....	61		
		<b>T</b>	
<b>P</b>		timing characteristics .....	22
packing list .....	52	trace antenna.....	31
parity .....	28	transmission .....	15
PC board layout.....	61		
pin information .....	24	<b>U</b>	
pinout notes.....	28	U.FL antenna .....	31
ports .....	11	user responsibility.....	44
power .....	22		
power draw		<b>W</b>	
measuring .....	23	Windows .....	11
processor.....	8		
programming external targets.....	64	<b>X</b>	
		xDot packing.....	64
<b>R</b>			
radio frequency interference .....	42		
range .....	28		