



**KSZ9031RNXIA-TR**  
MICROCHIP TECHNOLOGY

[Buy Now](#)



Looking for a discount?

[Check out our current promotions!](#)

Give us a call

**1-855-837-4225**

International: 1-415-281-3866

## Email Us

Sales and New Orders: [sales@verical.com](mailto:sales@verical.com)

Order Support: [support@verical.com](mailto:support@verical.com)

Suppliers: [Visit our seller page](#)

## Company Address

Arrow Electronics, Inc  
9201 East Dry Creek Road  
Centennial, CO 80112

---

## Gigabit Ethernet Transceiver with RGMII Support

---

### Features

- Single-Chip 10/100/1000 Mbps Ethernet Transceiver Suitable for IEEE 802.3 Applications
- RGMII Timing Supports On-Chip Delay According to RGMII Version 2.0, with Programming Options for External Delay and Making Adjustments and Corrections to TX and RX Timing Paths
- RGMII with 3.3V/2.5V/1.8V Tolerant I/Os
- Auto-Negotiation to Automatically Select the Highest Link-Up Speed (10/100/1000 Mbps) and Duplex (Half/Full)
- On-Chip Termination Resistors for the Differential Pairs
- On-Chip LDO Controller to Support Single 3.3V Supply Operation – Requires Only One External FET to Generate 1.2V for the Core
- Jumbo Frame Support up to 16 KB
- 125 MHz Reference Clock Output
- Energy Detect Power-Down Mode for Reduced Power Consumption When the Cable is Not Attached
- Wake-On-LAN (WOL) Support with Robust Custom-Packet Detection
- Programmable LED Outputs for Link, Activity, and Speed
- Baseline Wander Correction
- LinkMD TDR-Based Cable Diagnostic to Identify Faulty Copper Cabling
- Parametric NAND Tree Support to Detect Faults Between Chip I/Os and Board
- Loopback Modes for Diagnostics
- Automatic MDI/MDI-X Crossover to Detect and Correct Pair Swap at all Speeds of Operation
- Automatic Detection and Correction of Pair Swaps, Pair Skew, and Pair Polarity
- MDC/MDIO Management Interface for PHY Register Configuration
- Interrupt Pin Option
- Power-Down and Power-Saving Modes

- Operating Voltages
  - Core (DVDDL, AVDDL, AVDDL\_PLL): 1.2V (External FET or Regulator)
  - VDD I/O (DVDDH): 3.3V, 2.5V, or 1.8V
  - Transceiver (AVDDH): 3.3V or 2.5V (Commercial Temp.)
- AEC-Q100 Grade 3 (KSZ9031RNXUA/UB) and Grade 2 (KSZ9031RNXVA/VB) Qualified for Automotive Applications
- 48-pin QFN (7 mm × 7 mm) Package

### Target Applications

- Laser/Network Printer
- Network Attached Storage (NAS)
- Network Server
- Gigabit LAN on Motherboard (GLOM)
- Broadband Gateway
- Gigabit SOHO/SMB Router
- IPTV
- IP Set-Top Box
- Game Console
- Triple-Play (Data, Voice, Video) Media Center
- Industrial Control
- Automotive In-Vehicle Networking

## TO OUR VALUED CUSTOMERS

It is our intention to provide our valued customers with the best documentation possible to ensure successful use of your Microchip products. To this end, we will continue to improve our publications to better suit your needs. Our publications will be refined and enhanced as new volumes and updates are introduced.

If you have any questions or comments regarding this publication, please contact the Marketing Communications Department via E-mail at [docerrors@microchip.com](mailto:docerrors@microchip.com). We welcome your feedback.

### Most Current Data Sheet

To obtain the most up-to-date version of this data sheet, please register at our Worldwide Web site at:

<http://www.microchip.com>

You can determine the version of a data sheet by examining its literature number found on the bottom outside corner of any page. The last character of the literature number is the version number, (e.g., DS30000000A is version A of document DS30000000).

### Errata

An errata sheet, describing minor operational differences from the data sheet and recommended workarounds, may exist for current devices. As device/documentation issues become known to us, we will publish an errata sheet. The errata will specify the revision of silicon and revision of document to which it applies.

To determine if an errata sheet exists for a particular device, please check with one of the following:

- Microchip's Worldwide Web site; <http://www.microchip.com>
- Your local Microchip sales office (see last page)

When contacting a sales office, please specify which device, revision of silicon and data sheet (include -literature number) you are using.

### Customer Notification System

Register on our web site at [www.microchip.com](http://www.microchip.com) to receive the most current information on all of our products.

## Table of Contents

1.0 Introduction .....	4
2.0 Pin Description and Configuration .....	5
3.0 Functional Description .....	13
4.0 Register Descriptions .....	31
5.0 Operational Characteristics .....	52
6.0 Electrical Characteristics .....	53
7.0 Timing Diagrams .....	57
8.0 Reset Circuit .....	63
9.0 Reference Circuits — LED Strap-In Pins .....	65
10.0 Reference Clock - Connection and Selection .....	66
11.0 On-Chip LDO Controller - MOSFET Selection .....	66
12.0 Magnetic - Connection and Selection .....	67
13.0 Package Outlines .....	69
Appendix A: Data Sheet Revision History .....	78
The Microchip Web Site .....	80
Customer Change Notification Service .....	80
Customer Support .....	80
Product Identification System .....	81

# KSZ9031RNX

## 1.0 INTRODUCTION

### 1.1 General Description

The KSZ9031RNX is a completely integrated triple-speed (10BASE-T/100BASE-TX/1000BASE-T) Ethernet physical-layer transceiver for transmission and reception of data on standard CAT-5 unshielded twisted pair (UTP) cable.

The KSZ9031RNX provides the Reduced Gigabit Media Independent Interface (RGMII) for direct connection to RGMII MACs in Gigabit Ethernet processors and switches for data transfer at 10/100/1000 Mbps.

The KSZ9031RNX reduces board cost and simplifies board layout by using on-chip termination resistors for the four differential pairs and by integrating an LDO controller to drive a low-cost MOSFET to supply the 1.2V core.

The KSZ9031RNX offers diagnostic features to facilitate system bring-up and debugging in production testing and in product deployment. Parametric NAND tree support enables fault detection between KSZ9031 I/Os and the board. The LinkMD<sup>®</sup> TDR-based cable diagnostic identifies faulty copper cabling. Remote and local loopback functions verify analog and digital data paths.

The standard KSZ9031RNX is available in a 48-pin, lead-free QFN package, and the AEC-Q100 automotive qualified parts, KSZ9031RNXUA/UB and KSZ9031RNXVA/VB, are available in a 48-pin lead-free VQFN (wetable) package.

**FIGURE 1-1: SYSTEM BLOCK DIAGRAM**

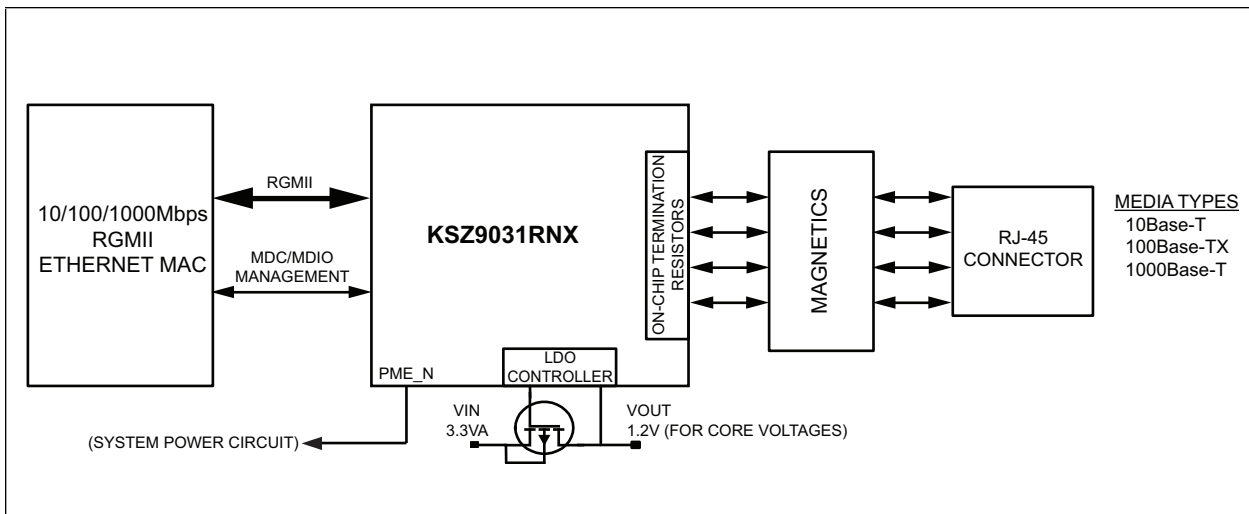

## 2.0 PIN DESCRIPTION AND CONFIGURATION

FIGURE 2-1: 48-QFN PIN ASSIGNMENT (TOP VIEW)

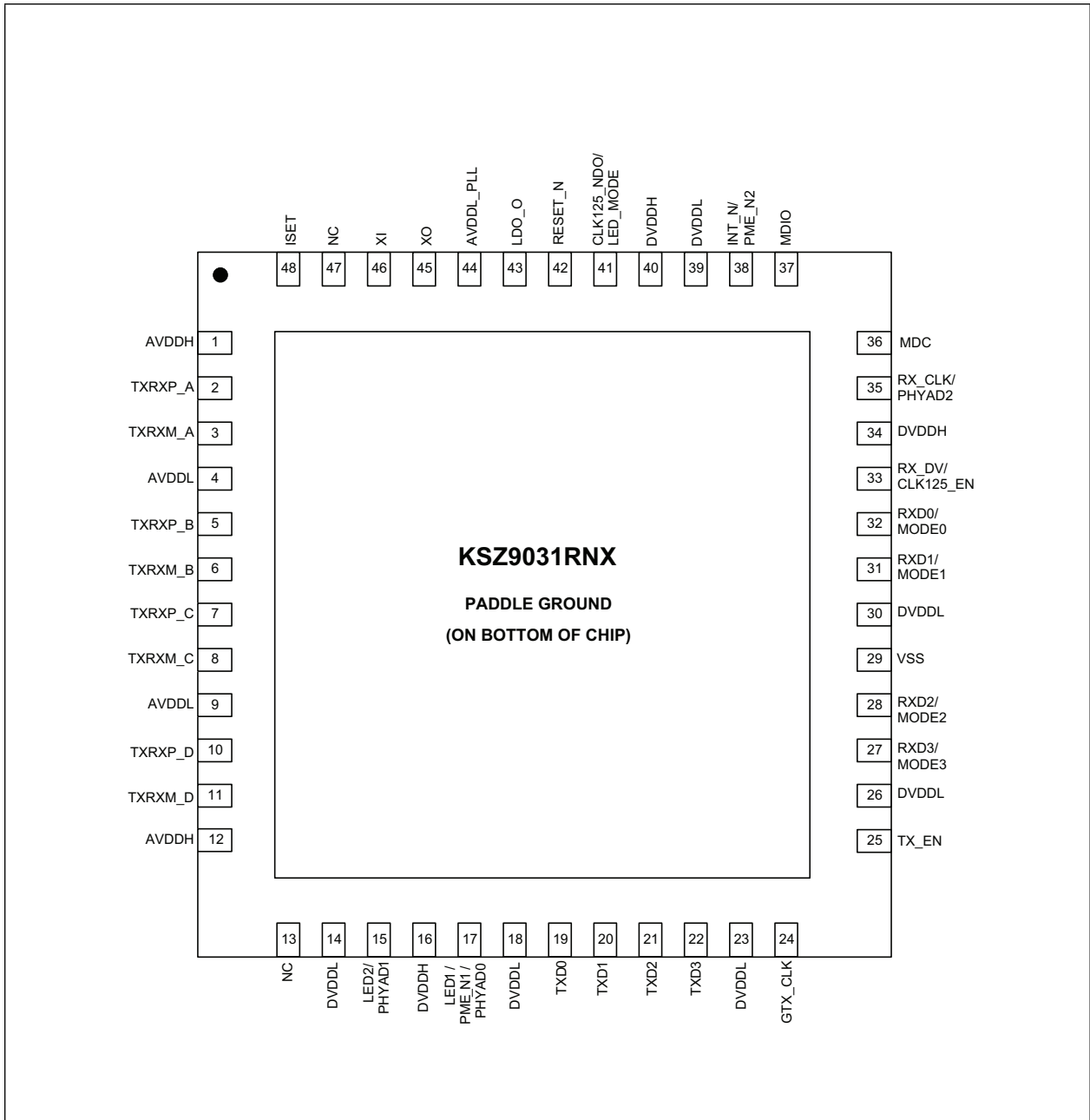

# KSZ9031RNX

TABLE 2-1: SIGNALS - KSZ9031RNX

Pin Number	Pin Name	Type Note 2-1	Description
1	AVDDH	P	3.3V/2.5V (commercial temp only) analog $V_{DD}$
2	TXRXP_A	I/O	Media Dependent Interface[0], positive signal of differential pair 1000BASE-T mode: TXRXP_A corresponds to BI_DA+ for MDI configuration and BI_DB+ for MDI-X configuration, respectively. 10BASE-T/100BASE-TX mode: TXRXP_A is the positive transmit signal (TX+) for MDI configuration and the positive receive signal (RX+) for MDI-X configuration, respectively.
3	TXRXM_A	I/O	Media Dependent Interface[0], negative signal of differential pair 1000BASE-T mode: TXRXM_A corresponds to BI_DA- for MDI configuration and BI_DB- for MDI-X configuration, respectively. 10BASE-T/100BASE-TX mode: TXRXM_A is the negative transmit signal (TX-) for MDI configuration and the negative receive signal (RX-) for MDI-X configuration, respectively.
4	AVDDL	P	1.2V analog $V_{DD}$
5	TXRXP_B	I/O	Media Dependent Interface[1], positive signal of differential pair 1000BASE-T mode: TXRXP_B corresponds to BI_DB+ for MDI configuration and BI_DA+ for MDI-X configuration, respectively. 10BASE-T/100BASE-TX mode: TXRXP_B is the positive receive signal (RX+) for MDI configuration and the positive transmit signal (TX+) for MDI-X configuration, respectively.
6	TXRXM_B	I/O	Media Dependent Interface[1], negative signal of differential pair 1000BASE-T mode: TXRXM_B corresponds to BI_DB- for MDI configuration and BI_DA- for MDI-X configuration, respectively. 10BASE-T/100BASE-TX mode: TXRXM_B is the negative receive signal (RX-) for MDI configuration and the negative transmit signal (TX-) for MDI-X configuration, respectively.
7	TXRXP_C	I/O	Media Dependent Interface[2], positive signal of differential pair 1000BASE-T mode: TXRXP_C corresponds to BI_DC+ for MDI configuration and BI_DD+ for MDI-X configuration, respectively. 10BASE-T/100BASE-TX mode: TXRXP_C is not used.
8	TXRXM_C	I/O	Media Dependent Interface[2], negative signal of differential pair 1000BASE-T mode: TXRXM_C corresponds to BI_DC- for MDI configuration and BI_DD- for MDI-X configuration, respectively. 10BASE-T/100BASE-TX mode: TXRXM_C is not used.
9	AVDDL	P	1.2V analog $V_{DD}$

TABLE 2-1: SIGNALS - KSZ9031RNX (CONTINUED)

Pin Number	Pin Name	Type Note 2-1	Description
10	TXRXP_D	I/O	Media Dependent Interface[3], positive signal of differential pair 1000BASE-T mode: TXRXP_D corresponds to BI_DD+ for MDI configuration and BI_DC+ for MDI-X configuration, respectively. 10BASE-T/100BASE-TX mode: TXRXP_D is not used.
11	TXRXM_D	I/O	Media Dependent Interface[3], negative signal of differential pair 1000BASE-T mode: TXRXM_D corresponds to BI_DD- for MDI configuration and BI_DC- for MDI-X configuration, respectively. 10BASE-T/100BASE-TX mode: TXRXM_D is not used.
12	AVDDH	P	3.3V/2.5V (commercial temp only) analog V <sub>DD</sub>
13	NC	—	No connect. This pin is not bonded and can be connected to digital ground for footprint compatibility with the KSZ9021RN Gigabit PHY.
14	DVDDL	P	1.2V digital V <sub>DD</sub>

# KSZ9031RNX

TABLE 2-1: SIGNALS - KSZ9031RNX (CONTINUED)

Pin Number	Pin Name	Type Note 2-1	Description			
15	LED2/ PHYAD1	I/O	LED output: Programmable LED2 output Config mode: The pull-up/pull-down value is latched as PHYAD[1] during power-up/reset. See the <a href="#">Strap-In Options - KSZ9031RNX</a> section for details. The LED2 pin is programmed by the LED_MODE strapping option (Pin 41), and is defined as follows: <b>Single-LED Mode</b>			
			<b>Link</b>	<b>Pin State</b>	<b>LED Definition</b>	
			Link Off	H	OFF	
			Link On (any speed)	L	ON	
			<b>Tri-Color Dual-LED Mode</b>			
			<b>Link/Activity</b>	<b>Pin State</b>		<b>LED Definition</b>
				<b>LED2</b>	<b>LED1</b>	<b>LED2</b> <b>LED1</b>
			Link Off	H	H	OFF    OFF
			1000 Link/No Activity	L	H	ON    OFF
			1000 Link/Activity (RX, TX)	Toggle	H	Blinking    OFF
			100 Link/No Activity	H	L	OFF    ON
			100 Link/Activity (RX, TX)	H	Toggle	OFF    Blinking
			10 Link/No Activity	L	L	ON    ON
			10 Link/Activity (RX, TX)	Toggle	Toggle	Blinking    Blinking
For tri-color dual-LED mode, LED2 works in conjunction with LED1 (Pin 17) to indicate 10 Mbps link and activity.						
16	DVDDH	P	3.3V, 2.5V, or 1.8V digital V <sub>DD_I/O</sub>			

**TABLE 2-1: SIGNALS - KSZ9031RNX (CONTINUED)**

Pin Number	Pin Name	Type Note 2-1	Description			
17	LED1/ PHYAD0/ PME_N1	I/O	<p>LED1 output: Programmable LED1 output</p> <p>Config mode: The voltage on this pin is sampled and latched during the power-up/reset process to determine the value of PHYAD[0]. See the <a href="#">Strap-In Options - KSZ9031RNX</a> section for details.</p> <p>PME_N output: Programmable PME_N output (pin option 1). This pin function requires an external pull-up resistor to DVDDH (digital <math>V_{DD\_I/O}</math>) in a range from 1.0 k<math>\Omega</math> to 4.7 k<math>\Omega</math>. When asserted low, this pin signals that a WOL event has occurred.</p> <p>This pin is not an open-drain for all operating modes.</p> <p>The LED1 pin is programmed by the LED_MODE strapping option (Pin 41), and is defined as follows:</p>			
			<b>Single-LED Mode</b>			
			<b>Activity</b>	<b>Pin State</b>	<b>LED Definition</b>	
			No Activity	H	OFF	
			Activity (RX, TX)	Toggle	Blinking	
			<b>Tri-Color Dual-LED Mode</b>			
			<b>Link/Activity</b>	<b>Pin State</b>		<b>LED Definition</b>
				<b>LED2</b>	<b>LED1</b>	<b>LED2</b> <b>LED1</b>
			Link Off	H	H	OFF    OFF
			1000 Link/No Activity	L	H	ON    OFF
			1000 Link/Activity (RX, TX)	Toggle	H	Blinking    OFF
			100 Link/No Activity	H	L	OFF    ON
			100 Link/Activity (RX, TX)	H	Toggle	OFF    Blinking
			10 Link/No Activity	L	L	ON    ON
			10 Link/Activity (RX, TX)	Toggle	Toggle	Blinking    Blinking
For tri-color dual-LED mode, LED1 works in conjunction with LED2 (Pin 15) to indicate 10 Mbps link and activity.						
18	DVDDL	P	1.2V digital $V_{DD}$			
19	TXD0	I	RGMII mode: RGMII TD0 (Transmit Data 0) input			
20	TXD1	I	RGMII mode: RGMII TD1 (Transmit Data 1) input			
21	TXD2	I	RGMII mode: RGMII TD2 (Transmit Data 2) input			
22	TXD3	I	RGMII mode: RGMII TD3 (Transmit Data 3) input			
23	DVDDL	P	1.2V digital $V_{DD}$			
24	GTX_CLK	I	RGMII mode: RGMII TXC (Transmit Reference Clock) input			

# KSZ9031RNX

TABLE 2-1: SIGNALS - KSZ9031RNX (CONTINUED)

Pin Number	Pin Name	Type Note 2-1	Description
25	TX_EN	I	RGMII mode: RGMII TX_CTL (Transmit Control) input
26	DVDDL	P	1.2V digital V <sub>DD</sub>
27	RXD3/ MODE3	I/O	RGMII mode: RGMII RD3 (Receive Data 3) output Config mode: The pull-up/pull-down value is latched as MODE3 during power-up/reset. See the <a href="#">Strap-In Options - KSZ9031RNX</a> section for details.
28	RXD2/ MODE2	I/O	RGMII mode: RGMII RD2 (Receive Data 2) output Config mode: The pull-up/pull-down value is latched as MODE2 during power-up/reset. See the <a href="#">Strap-In Options - KSZ9031RNX</a> section for details.
29	VSS	GND	Digital ground
30	DVDDL	P	1.2V digital V <sub>DD</sub>
31	RXD1/ MODE1	I/O	RGMII mode: RGMII RD1 (Receive Data 1) output Config mode: The pull-up/pull-down value is latched as MODE1 during power-up/reset. See the <a href="#">Strap-In Options - KSZ9031RNX</a> section for details.
32	RXD0/ MODE0	I/O	RGMII mode: RGMII RD0 (Receive Data 0) output Config mode: The pull-up/pull-down value is latched as MODE0 during power-up/reset. See the <a href="#">Strap-In Options - KSZ9031RNX</a> section for details.
33	RX_DV/ CLK125_EN	I/O	RGMII mode: RGMII RX_CTL (Receive Control) output Config mode: Latched as CLK125_NDO Output Enable during power-up/reset. See the <a href="#">Strap-In Options - KSZ9031RNX</a> section for details.
34	DVDDH	P	3.3V, 2.5V, or 1.8V digital V <sub>DD_I/O</sub>
35	RX_CLK/ PHYAD2	I/O	RGMII mode: RGMII RXC (Receive Reference Clock) output Config mode: The pull-up/pull-down value is latched as PHYAD[2] during power-up/reset. See the <a href="#">Strap-In Options - KSZ9031RNX</a> section for details.
36	MDC	Ipu	Management data clock input This pin is the input reference clock for MDIO (Pin 37).
37	MDIO	Ipu/O	Management data input/output This pin is synchronous to MDC (Pin 36) and requires an external pull-up resistor to DVDDH (digital V <sub>DD_I/O</sub> ) in a range from 1.0 kΩ to 4.7 kΩ.
38	INT_N/ PME_N2	O	Interrupt output: Programmable interrupt output, with Register 1Bh as the Interrupt Control/Status register, for programming the interrupt conditions and reading the interrupt status. Register 1Fh, Bit [14] sets the interrupt output to active low (default) or active high. PME_N output: Programmable PME_N output (pin option 2). When asserted low, this pin signals that a WOL event has occurred. For Interrupt (when active low) and PME functions, this pin requires an external pull-up resistor to DVDDH (digital V <sub>DD_I/O</sub> ) in a range from 1.0 kΩ to 4.7 kΩ. This pin is not an open-drain for all operating modes.
39	DVDDL	P	1.2V digital V <sub>DD</sub>
40	DVDDH	P	3.3V, 2.5V, or 1.8V digital V <sub>DD_I/O</sub>

**TABLE 2-1: SIGNALS - KSZ9031RNX (CONTINUED)**

Pin Number	Pin Name	Type Note 2-1	Description
41	CLK125_NDO/ LED_MODE	I/O	125 MHz clock output This pin provides a 125 MHz reference clock output option for use by the MAC. Config mode: The pull-up/pull-down value is latched as LED_MODE during power-up/reset. See the <a href="#">Strap-In Options - KSZ9031RNX</a> section for details.
42	RESET_N	Ipu	Chip reset (active low) Hardware pin configurations are strapped-in at the de-assertion (rising edge) of RESET_N. See the <a href="#">Strap-In Options - KSZ9031RNX</a> section for details.
43	LDO_O	O	On-chip 1.2V LDO controller output This pin drives the input gate of a P-channel MOSFET to generate 1.2V for the chip's core voltages. If the system provides 1.2V and this pin is not used, it can be left floating. <b>Note:</b> This pin should never be driven externally.
44	AVDDL_PLL	P	1.2V analog V <sub>DD</sub> for PLL
45	XO	O	25 MHz crystal feedback This pin is a no connect if an oscillator or external clock source is used.
46	XI	I	Crystal/Oscillator/External Clock input 25 MHz ±50 ppm tolerance
47	NC	—	No connect This pin is not bonded and can be connected to AVDDH power for footprint compatibility with the KSZ9021RN Gigabit PHY.
48	ISET	I/O	Set the transmit output level Connect a 12.1 kΩ 1% resistor to ground on this pin.
Paddle	P_GND	GND	Exposed paddle on bottom of chip Connect P_GND to ground.

**Note 2-1**

P = power supply

GND = ground

I = input

O = output

I/O = bi-directional

Ipu = Input with internal pull-up (see [Section 6.0, "Electrical Characteristics"](#) for value).

Ipu/O = Input with internal pull-up (see [Section 6.0, "Electrical Characteristics"](#) for value) during power-up/reset; output pin otherwise.

# KSZ9031RNX

Pin strap-ins are latched during power-up or reset. In some systems, the MAC receive input pins may be driven during power-up or reset, and consequently cause the PHY strap-in pins on the RGMII signals to be latched to an incorrect configuration. In this case, external pull-up or pull-down resistors should be added on the PHY strap-in pins to ensure the PHY is configured to the correct pin strap-in mode.

**TABLE 2-2: STRAP-IN OPTIONS - KSZ9031RNX**

Pin Number	Pin Name	Type Note 2-2	Description																																		
35 15 17	PHYAD2 PHYAD1 PHYAD0	I/O I/O I/O	The PHY address, PHYAD[2:0], is sampled and latched at power-up/reset and is configurable to any value from 0 to 7. Each PHY address bit is configured as follows: Pull-up = 1 Pull-down = 0 PHY Address Bits [4:3] are always set to '00'.																																		
27 28 31 32	MODE3 MODE2 MODE1 MODE0	I/O I/O I/O I/O	<p>The MODE[3:0] strap-in pins are sampled and latched at power-up/reset and are defined as follows:</p> <table border="1"> <thead> <tr> <th>MODE[3:0]</th> <th>Mode</th> </tr> </thead> <tbody> <tr><td>0000</td><td>Reserved - not used</td></tr> <tr><td>0001</td><td>Reserved - not used</td></tr> <tr><td>0010</td><td>Reserved - not used</td></tr> <tr><td>0011</td><td>Reserved - not used</td></tr> <tr><td>0100</td><td>NAND tree mode</td></tr> <tr><td>0101</td><td>Reserved - not used</td></tr> <tr><td>0110</td><td>Reserved - not used</td></tr> <tr><td>0111</td><td>Chip power-down mode</td></tr> <tr><td>1000</td><td>Reserved - not used</td></tr> <tr><td>1001</td><td>Reserved - not used</td></tr> <tr><td>1010</td><td>Reserved - not used</td></tr> <tr><td>1011</td><td>Reserved - not used</td></tr> <tr><td>1100</td><td>RGMII mode - Advertise 1000BASE-T full-duplex only</td></tr> <tr><td>1101</td><td>RGMII mode - Advertise 1000BASE-T full- and half-duplex only</td></tr> <tr><td>1110</td><td>RGMII mode - Advertise all capabilities (10/100/1000 speed half-/full-duplex), except 1000BASE-T half-duplex</td></tr> <tr><td>1111</td><td>RGMII mode - Advertise all capabilities (10/100/1000 speed half-/full-duplex)</td></tr> </tbody> </table>	MODE[3:0]	Mode	0000	Reserved - not used	0001	Reserved - not used	0010	Reserved - not used	0011	Reserved - not used	0100	NAND tree mode	0101	Reserved - not used	0110	Reserved - not used	0111	Chip power-down mode	1000	Reserved - not used	1001	Reserved - not used	1010	Reserved - not used	1011	Reserved - not used	1100	RGMII mode - Advertise 1000BASE-T full-duplex only	1101	RGMII mode - Advertise 1000BASE-T full- and half-duplex only	1110	RGMII mode - Advertise all capabilities (10/100/1000 speed half-/full-duplex), except 1000BASE-T half-duplex	1111	RGMII mode - Advertise all capabilities (10/100/1000 speed half-/full-duplex)
MODE[3:0]	Mode																																				
0000	Reserved - not used																																				
0001	Reserved - not used																																				
0010	Reserved - not used																																				
0011	Reserved - not used																																				
0100	NAND tree mode																																				
0101	Reserved - not used																																				
0110	Reserved - not used																																				
0111	Chip power-down mode																																				
1000	Reserved - not used																																				
1001	Reserved - not used																																				
1010	Reserved - not used																																				
1011	Reserved - not used																																				
1100	RGMII mode - Advertise 1000BASE-T full-duplex only																																				
1101	RGMII mode - Advertise 1000BASE-T full- and half-duplex only																																				
1110	RGMII mode - Advertise all capabilities (10/100/1000 speed half-/full-duplex), except 1000BASE-T half-duplex																																				
1111	RGMII mode - Advertise all capabilities (10/100/1000 speed half-/full-duplex)																																				
33	CLK125_EN	I/O	CLK125_EN is sampled and latched at power-up/reset and is defined as follows: Pull-up (1) = Enable 125 MHz clock output Pull-down (0) = Disable 125 MHz clock output Pin 41 (CLK125_NDO) provides the 125 MHz reference clock output option for use by the MAC.																																		
41	LED_MODE	I/O	LED_MODE is sampled and latched at power-up/reset and is defined as follows: Pull-up (1) = Single-LED mode Pull-down (0) = Tri-color dual-LED mode																																		

**Note 2-2** I/O = Bi-directional.

## 3.0 FUNCTIONAL DESCRIPTION

The KSZ9031RNX is a completely integrated triple-speed (10BASE-T/100BASE-TX/1000BASE-T) Ethernet physical layer transceiver solution for transmission and reception of data over a standard CAT-5 unshielded twisted pair (UTP) cable.

The KSZ9031RNX reduces board cost and simplifies board layout by using on-chip termination resistors for the four differential pairs and by integrating an LDO controller to drive a low-cost MOSFET to supply the 1.2V core.

On the copper media interface, the KSZ9031RNX can automatically detect and correct for differential pair misplacements and polarity reversals, and correct propagation delays and re-sync timing between the four differential pairs, as specified in the IEEE 802.3 standard for 1000BASE-T operation.

The KSZ9031RNX provides the RGMII interface for connection to RGMII MACs in Gigabit Ethernet processors and switches for data transfer at 10/100/1000 Mbps.

Figure 3-1 shows a high-level block diagram of the KSZ9031RNX.

**FIGURE 3-1: KSZ9031RNX BLOCK DIAGRAM**

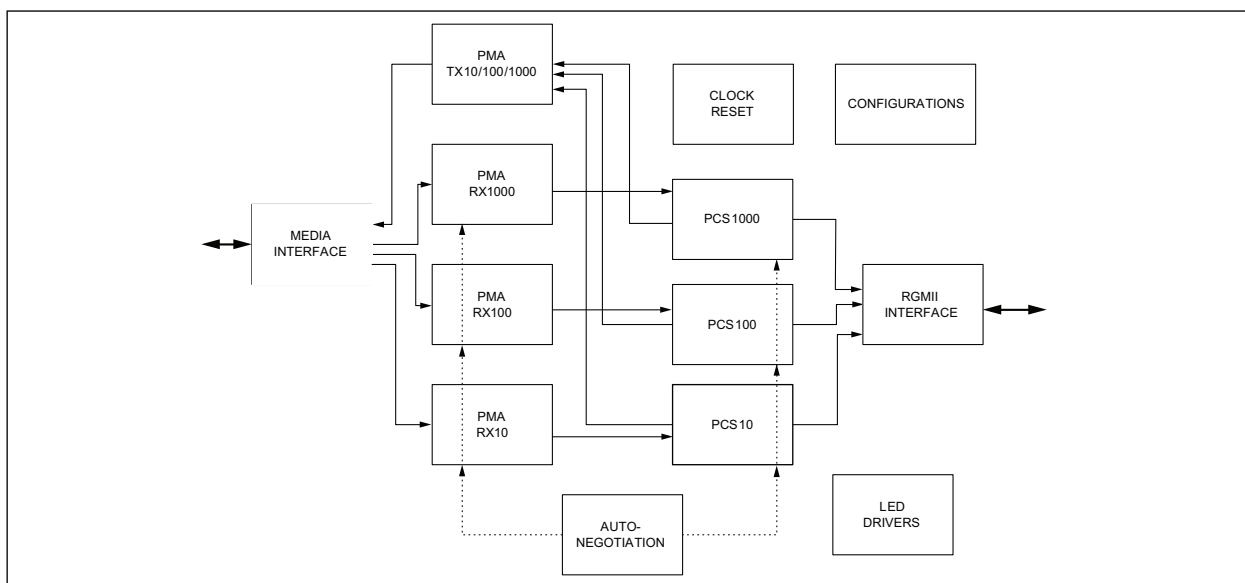

### 3.1 10BASE-T/100BASE-TX Transceiver

#### 3.1.1 100BASE-TX TRANSMIT

The 100BASE-TX transmit function performs parallel-to-serial conversion, 4B/5B coding, scrambling, NRZ-to-NRZI conversion, and MLT-3 encoding and transmission.

The circuitry starts with a parallel-to-serial conversion, which converts the MII data from the MAC into a 125 MHz serial bit stream. The data and control stream is then converted into 4B/5B coding, followed by a scrambler. The serialized data is further converted from NRZ-to-NRZI format, and then transmitted in MLT-3 current output. The output current is set by an external 12.1 kΩ 1% resistor for the 1:1 transformer ratio.

The output signal has a typical rise/fall time of 4 ns and complies with the ANSI TP-PMD standard regarding amplitude balance, and overshoot. The wave-shaped 10BASE-T output is also incorporated into the 100BASE-TX transmitter.

#### 3.1.2 100BASE-TX RECEIVE

The 100BASE-TX receiver function performs adaptive equalization, DC restoration, MLT-3-to-NRZI conversion, data and clock recovery, NRZI-to-NRZ conversion, de-scrambling, 4B/5B decoding, and serial-to-parallel conversion.

The receiving side starts with the equalization filter to compensate for inter-symbol interference (ISI) over the twisted pair cable. Because the amplitude loss and phase distortion are a function of the cable length, the equalizer must adjust its characteristics to optimize performance. In this design, the variable equalizer makes an initial estimation based on comparisons of incoming signal strength against some known cable characteristics, then tunes itself for optimization. This is an ongoing process and self-adjusts against environmental changes such as temperature variations.

# KSZ9031RNX

---

Next, the equalized signal goes through a DC-restoration and data-conversion block. The DC-restoration circuit compensates for the effect of baseline wander and improves the dynamic range. The differential data conversion circuit converts the MLT-3 format back to NRZI. The slicing threshold is also adaptive.

The clock-recovery circuit extracts the 125 MHz clock from the edges of the NRZI signal. This recovered clock is then used to convert the NRZI signal into the NRZ format. This signal is sent through the de-scrambler followed by the 4B/5B decoder. Finally, the NRZ serial data is converted to the RGMII format and provided as the input data to the MAC.

### 3.1.3 SCRAMBLER/DE-SCRAMBLER (100BASE-TX ONLY)

The purpose of the scrambler is to spread the power spectrum of the signal to reduce electromagnetic interference (EMI) and baseline wander. Transmitted data is scrambled using an 11-bit wide linear feedback shift register (LFSR). The scrambler generates a 2047-bit non-repetitive sequence, then the receiver de-scrambles the incoming data stream using the same sequence as at the transmitter.

### 3.1.4 10BASE-T TRANSMIT

The 10BASE-T output drivers are incorporated into the 100BASE-TX drivers to allow for transmission with the same magnetic. The drivers perform internal wave-shaping and pre-emphasis, and output signals with typical amplitude of 2.5V peak for standard 10BASE-T mode and 1.75V peak for energy-efficient 10BASE-Te mode. The 10BASE-T/10BASE-Te signals have harmonic contents that are at least 31 dB below the fundamental frequency when driven by an all-ones Manchester-encoded signal.

### 3.1.5 10BASE-T RECEIVE

On the receive side, input buffer and level-detecting squelch circuits are used. A differential input receiver circuit and a phase-locked loop (PLL) perform the decoding function. The Manchester-encoded data stream is separated into clock signal and NRZ data. A squelch circuit rejects signals with levels less than 300 mV or with short pulse widths to prevent noises at the receive inputs from falsely triggering the decoder. When the input exceeds the squelch limit, the PLL locks onto the incoming signal and the KSZ9031RNX decodes a data frame. The receiver clock is maintained active during idle periods between receiving data frames.

The KSZ9031RNX removes all 7 bytes of the preamble and presents the received frame starting with the SFD (start of frame delimiter) to the MAC.

Auto-polarity correction is provided for the receiving differential pair to automatically swap and fix the incorrect +/- polarity wiring in the cabling.

## 3.2 1000BASE-T Transceiver

The 1000BASE-T transceiver is based-on a mixed-signal/digital-signal processing (DSP) architecture, which includes the analog front-end, digital channel equalizers, trellis encoders/decoders, echo cancelers, cross-talk cancelers, precision clock recovery scheme, and power-efficient line drivers.

[Figure 3-2](#) shows a high-level block diagram of a single channel of the 1000BASE-T transceiver for one of the four differential pairs.

**FIGURE 3-2: KSZ9031RNX 1000BASE-T BLOCK DIAGRAM - SINGLE CHANNEL**

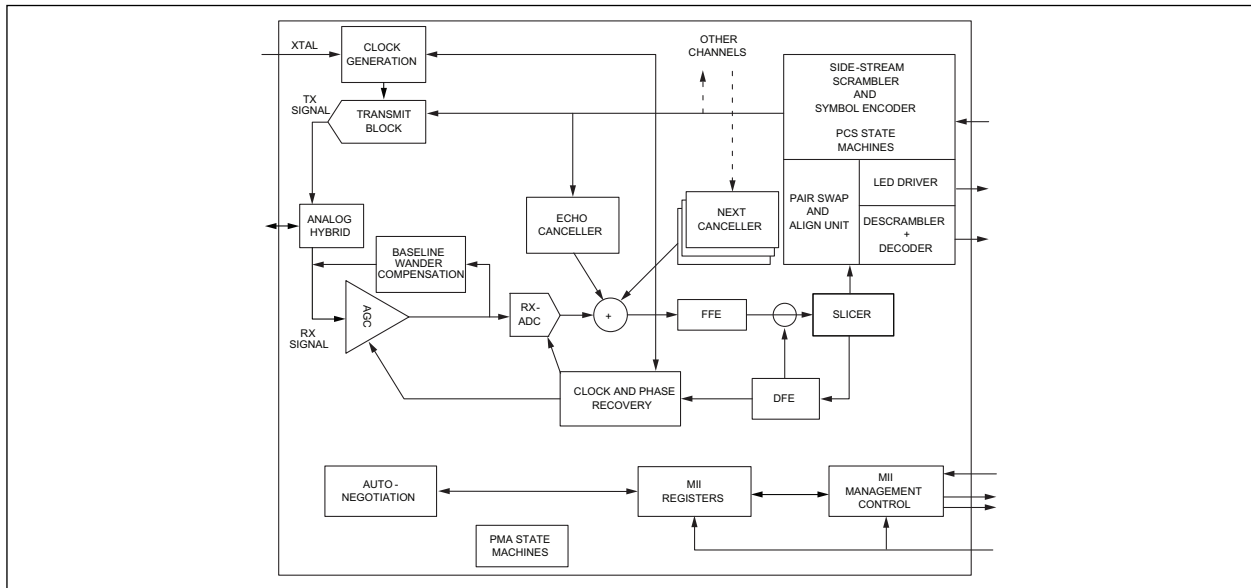

### 3.2.1 ANALOG ECHO-CANCELLATION CIRCUIT

In 1000BASE-T mode, the analog echo-cancellation circuit helps to reduce the near-end echo. This analog hybrid circuit relieves the burden of the ADC and the adaptive equalizer.

This circuit is disabled in 10BASE-T/100BASE-TX mode.

### 3.2.2 AUTOMATIC GAIN CONTROL (AGC)

In 1000BASE-T mode, the automatic gain control (AGC) circuit provides initial gain adjustment to boost up the signal level. This pre-conditioning circuit is used to improve the signal-to-noise ratio of the receive signal.

### 3.2.3 ANALOG-TO-DIGITAL CONVERTER (ADC)

In 1000BASE-T mode, the analog-to-digital converter (ADC) digitizes the incoming signal. ADC performance is essential to the overall performance of the transceiver.

This circuit is disabled in 10BASE-T/100BASE-TX mode.

### 3.2.4 TIMING RECOVERY CIRCUIT

In 1000BASE-T mode, the mixed-signal clock recovery circuit together with the digital phase-locked loop is used to recover and track the incoming timing information from the received data. The digital phase-locked loop has very low long-term jitter to maximize the signal-to-noise ratio of the receive signal.

The 1000BASE-T slave PHY must transmit the exact receive clock frequency recovered from the received data back to the 1000BASE-T master PHY. Otherwise, the master and slave will not be synchronized after long transmission. This also helps to facilitate echo cancellation and NEXT removal.

### 3.2.5 ADAPTIVE EQUALIZER

In 1000BASE-T mode, the adaptive equalizer provides the following functions:

- Detection for partial response signaling
- Removal of NEXT and ECHO noise
- Channel equalization

Signal quality is degraded by residual echo that is not removed by the analog hybrid because of impedance mismatch. The KSZ9031RNX uses a digital echo canceler to further reduce echo components on the receive signal.

In 1000BASE-T mode, data transmission and reception occurs simultaneously on all four pairs of wires (four channels). This results in high-frequency cross-talk coming from adjacent wires. The KSZ9031RNX uses three NEXT cancelers on each receive channel to minimize the cross-talk induced by the other three channels.

# KSZ9031RNX

In 10BASE-T/100BASE-TX mode, the adaptive equalizer needs only to remove the inter-symbol interference and recover the channel loss from the incoming data.

## 3.2.6 TRELLIS ENCODER AND DECODER

In 1000BASE-T mode, the transmitted 8-bit data is scrambled into 9-bit symbols and further encoded into 4D-PAM5 symbols. The initial scrambler seed is determined by the specific PHY address to reduce EMI when more than one KSZ9031RNX is used on the same board. On the receiving side, the idle stream is examined first. The scrambler seed, pair skew, pair order, and polarity must be resolved through the logic. The incoming 4D-PAM5 data is then converted into 9-bit symbols and de-scrambled into 8-bit data.

## 3.3 Auto MDI/MDI-X

The Automatic MDI/MDI-X feature eliminates the need to determine whether to use a straight cable or a crossover cable between the KSZ9031RNX and its link partner. This auto-sense function detects the MDI/MDI-X pair mapping from the link partner, and assigns the MDI/MDI-X pair mapping of the KSZ9031RNX accordingly.

Table 3-1 shows the KSZ9031RNX 10/100/1000 pin configuration assignments for MDI/MDI-X pin mapping.

TABLE 3-1: MDI/MDI-X PIN MAPPING

Pin (RJ-45 Pair)	MDI			MDI-X		
	1000BASE-T	100BASE-T	10BASE-T	1000BASE-T	100BASE-T	10BASE-T
TXRXP/M_A (1, 2)	A+/-	TX+/-	TX+/-	B+/-	RX+/-	RX+/-
TXRXP/M_B (3, 6)	B+/-	RX+/-	RX+/-	A+/-	TX+/-	TX+/-
TXRXP/M_C (4, 5)	C+/-	Not Used	Not Used	D+/-	Not Used	Not Used
TXRXP/M_D (7, 8)	D+/-	Not Used	Not Used	C+/-	Not Used	Not Used

Auto MDI/MDI-X is enabled by default. It is disabled by writing a one to Register 1Ch, Bit [6]. MDI and MDI-X mode is set by Register 1Ch, Bit [7] if Auto MDI/MDI-X is disabled.

An isolation transformer with symmetrical transmit and receive data paths is recommended to support Auto MDI/MDI-X.

## 3.4 Pair-Swap, Alignment, and Polarity Check

In 1000BASE-T mode, the KSZ9031RNX

- Detects incorrect channel order and automatically restores the pair order for the A, B, C, D pairs (four channels).
- Supports 50 ns  $\pm$  10 ns difference in propagation delay between pairs of channels in accordance with the IEEE 802.3 standard, and automatically corrects the data skew so the corrected four pairs of data symbols are synchronized.

Incorrect pair polarities of the differential signals are automatically corrected for all speeds.

## 3.5 Wave Shaping, Slew-Rate Control, and Partial Response

In communication systems, signal transmission encoding methods are used to provide the noise-shaping feature and to minimize distortion and error in the transmission channel.

- For 1000BASE-T, a special partial-response signaling method is used to provide the band-limiting feature for the transmission path.
- For 100BASE-TX, a simple slew-rate control method is used to minimize EMI.
- For 10BASE-T, pre-emphasis is used to extend the signal quality through the cable.

## 3.6 PLL Clock Synthesizer

The KSZ9031RNX generates 125 MHz, 25 MHz, and 10 MHz clocks for system timing. Internal clocks are generated from the external 25 MHz crystal or reference clock.

## 3.7 Auto-Negotiation

The KSZ9031RNX conforms to the auto-negotiation protocol, defined in Clause 28 of the IEEE 802.3 Specification.

Auto-negotiation allows UTP (unshielded twisted pair) link partners to select the highest common mode of operation.

During auto-negotiation, link partners advertise capabilities across the UTP link to each other, and then compare their own capabilities with those they received from their link partners. The highest speed and duplex setting that is common to the two link partners is selected as the operating mode.

The following list shows the speed and duplex operation mode from highest-to-lowest:

- Priority 1: 1000BASE-T, full-duplex
- Priority 2: 1000BASE-T, half-duplex
- Priority 3: 100BASE-TX, full-duplex
- Priority 4: 100BASE-TX, half-duplex
- Priority 5: 10BASE-T, full-duplex
- Priority 6: 10BASE-T, half-duplex

If auto-negotiation is not supported or the KSZ9031RNX link partner is forced to bypass auto-negotiation for 10BASE-T and 100BASE-TX modes, the KSZ9031RNX sets its operating mode by observing the input signal at its receiver. This is known as parallel detection, and allows the KSZ9031RNX to establish a link by listening for a fixed signal protocol in the absence of the auto-negotiation advertisement protocol.

The auto-negotiation link-up process is shown in [Figure 3-3](#).

**FIGURE 3-3: AUTO-NEGOTIATION FLOW CHART**

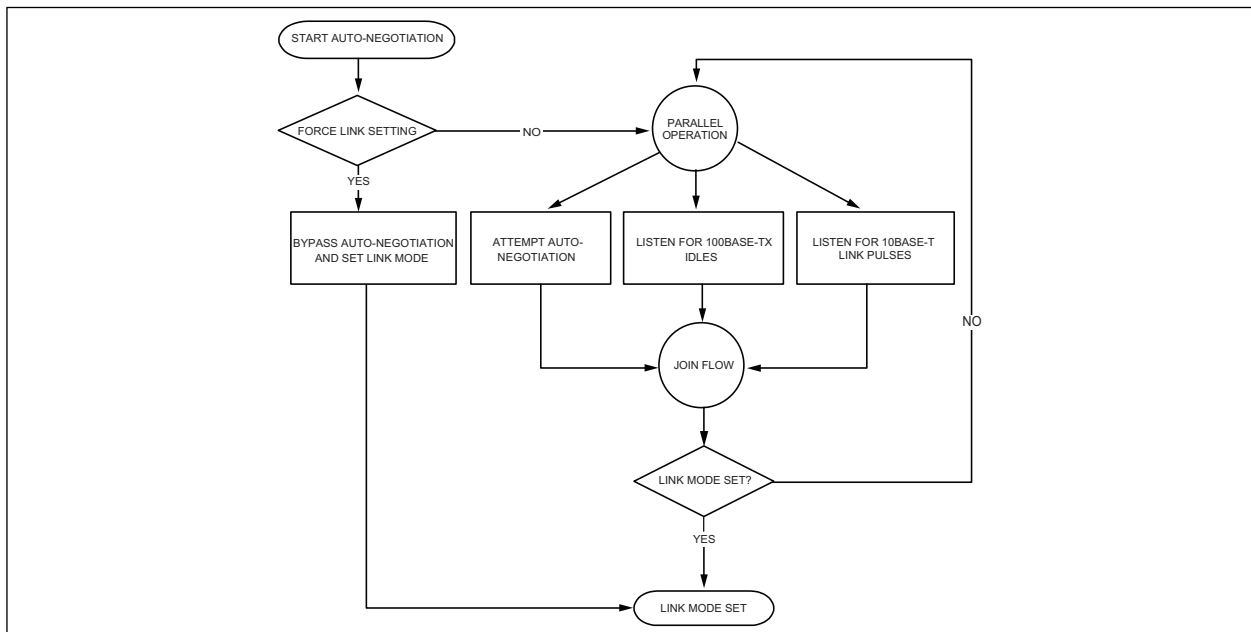

For 1000BASE-T mode, auto-negotiation is required and always used to establish a link. During 1000BASE-T auto-negotiation, the master and slave configuration is first resolved between link partners. Then the link is established with the highest common capabilities between link partners.

Auto-negotiation is enabled by default after power-up or hardware reset. After that, auto-negotiation can be enabled or disabled through Register 0h, Bit [12]. If auto-negotiation is disabled, the speed is set by Register 0h, Bits [6, 13] and the duplex is set by Register 0h, Bit [8].

If the speed is changed on the fly, the link goes down and auto-negotiation and parallel detection initiate until a common speed between KSZ9031RNX and its link partner is re-established for a link.

If the link is already established and there is no change of speed on the fly, the changes (for example, duplex and pause capabilities) will not take effect unless either auto-negotiation is restarted through Register 0h, Bit [9], or a link-down to link-up transition occurs (that is, disconnecting and reconnecting the cable).

# KSZ9031RNX

After auto-negotiation is completed, the link status is updated in Register 1h, Bit [2], and the link partner capabilities are updated in Registers 5h, 6h, 8h, and Ah.

The auto-negotiation finite state machines use interval timers to manage the auto-negotiation process. The duration of these timers under normal operating conditions is summarized in [Table 3-2](#).

**TABLE 3-2: AUTO-NEGOTIATION TIMERS**

Auto-Negotiation Interval Timers	Time Duration
Transmit Burst Interval	16 ms
Transmit Pulse Interval	68 $\mu$ s
FLP Detect Minimum Time	17.2 $\mu$ s
FLP Detect Maximum Time	185 $\mu$ s
Receive Minimum Burst Interval	6.8 ms
Receive Maximum Burst Interval	112 ms
Data Detect Minimum Interval	35.4 $\mu$ s
Data Detect Maximum Interval	95 $\mu$ s
NLP Test Minimum Interval	4.5 ms
NLP Test Maximum Interval	30 ms
Link Loss Time	52 ms
Break Link Time	1480 ms
Parallel Detection Wait Time	830 ms
Link Enable Wait Time	1000 ms

## 3.8 10/100 Mbps Speeds Only

Some applications require link-up to be limited to 10/100 Mbps speeds only.

After power-up/reset, the KSZ9031RNX can be restricted to auto-negotiate and link-up to 10/100 Mbps speeds only by programming the following register settings:

1. Set Register 0h, Bit [6] = '0' to remove 1000 Mbps speed.
2. Set Register 9h, Bits [9:8] = '00' to remove Auto-Negotiation advertisements for 1000 Mbps full-/half-duplex.
3. Write a '1' to Register 0h, Bit [9], a self-clearing bit, to force a restart of Auto-Negotiation.

Auto-Negotiation and 10BASE-T/100BASE-TX speeds use only differential pairs A (pins 2, 3) and B (pins 5, 6). Differential pairs C (pins 7, 8) and D (pins 10, 11) can be left as no connects.

## 3.9 RGMII Interface

The Reduced Gigabit Media Independent Interface (RGMII) supports on-chip data-to-clock delay timing according to the RGMII Version 2.0 Specification, with programming options for external delay timing and to adjust and correct TX and RX timing paths.

RGMII provides a common interface between RGMII PHYs and MACs, and has the following key characteristics:

- Pin count is reduced from 24 pins for the IEEE Gigabit Media Independent Interface (GMII) to 12 pins for RGMII.
- All speeds (10 Mbps, 100 Mbps, and 1000 Mbps) are supported at both half- and full-duplex.
- Data transmission and reception are independent and belong to separate signal groups.
- Transmit data and receive data are each four bits wide, a nibble.

In RGMII operation, the RGMII pins function as follows:

- The MAC sources the transmit reference clock, TXC, at 125 MHz for 1000 Mbps, 25 MHz for 100 Mbps, and 2.5 MHz for 10 Mbps.
- The PHY recovers and sources the receive reference clock, RXC, at 125 MHz for 1000 Mbps, 25 MHz for 100 Mbps, and 2.5 MHz for 10 Mbps.
- For 1000BASE-T, the transmit data, TXD[3:0], is presented on both edges of TXC, and the received data, RXD[3:0], is clocked out on both edges of the recovered 125 MHz clock, RXC.
- For 10BASE-T/100BASE-TX, the MAC holds TX\_CTL low until both PHY and MAC operate at the same speed.

During the speed transition, the receive clock is stretched on either a positive or negative pulse to ensure that no clock glitch is presented to the MAC.

- TX\_ER and RX\_ER are combined with TX\_EN and RX\_DV, respectively, to form TX\_CTL and RX\_CTL. These two RGMII control signals are valid at the falling clock edge.

After power-up or reset, the KSZ9031RNX is configured to RGMII mode if the MODE[3:0] strap-in pins are set to one of the RGMII mode capability options. See the [Strap-In Options - KSZ9031RNX](#) section.

The KSZ9031RNX has the option to output a 125 MHz reference clock on the CLK125\_NDO pin. This clock provides a lower-cost reference clock alternative for RGMII MACs that require a 125 MHz crystal or oscillator. The 125 MHz clock output is enabled after power-up or reset if the CLK125\_EN strap-in pin is pulled high.

### 3.9.1 RGMII SIGNAL DEFINITION

[Table 3-3](#) describes the RGMII signals. Refer to the RGMII Version 2.0 Specification for more detailed information.

**TABLE 3-3: RGMII SIGNAL DEFINITION**

RGMII Signal Name (per spec)	RGMII Signal Name (per KSZ9031RNX)	Pin Type (with respect to PHY)	Pin Type (with respect to MAC)	Description
TXC	GTX_CLK	Input	Output	Transmit Reference Clock (125MHz for 1000Mbps, 25MHz for 100Mbps, 2.5MHz for 10Mbps)
TX_CTL	TX_EN	Input	Output	Transmit Control
TXD[3:0]	TXD[3:0]	Input	Output	Transmit Data[3:0]
RXC	RX_CLK	Output	Input	Receive Reference Clock (125 MHz for 1000 Mbps, 25 MHz for 100 Mbps, 2.5 MHz for 10 Mbps)
RX_CTL	RX_DV	Output	Input	Receive Control
RXD[3:0]	RXD[3:0]	Output	Input	Receive Data[3:0]

### 3.9.2 RGMII SIGNAL DIAGRAM

The KSZ9031RNX RGMII pin connections to the MAC are shown in [Figure 3-4](#).

**FIGURE 3-4: KSZ9031RNX RGMII INTERFACE**

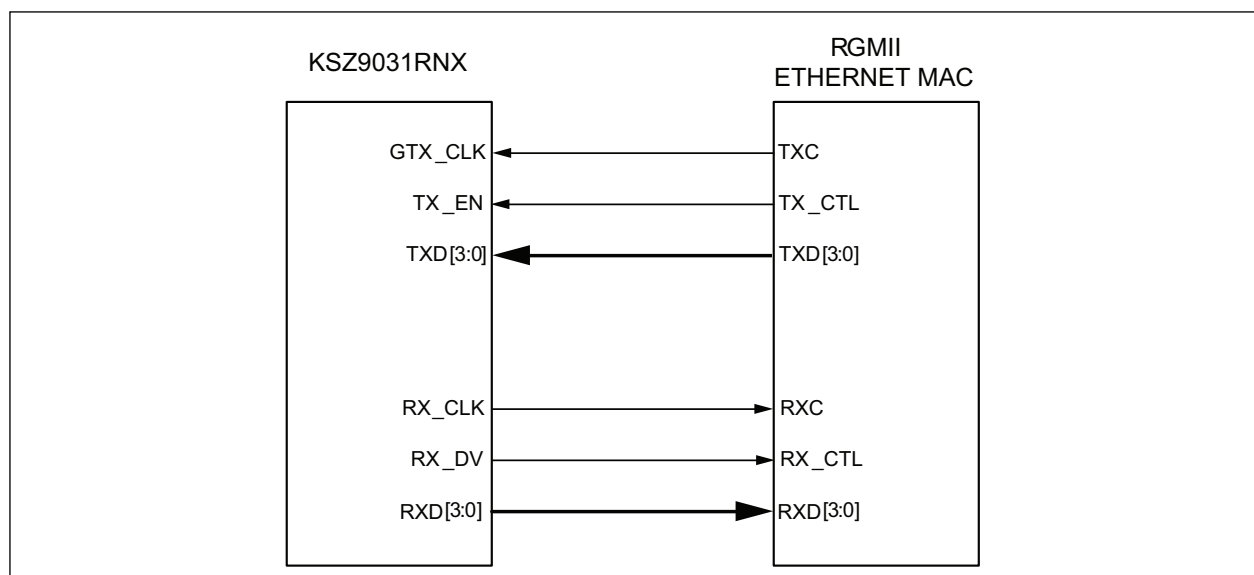

# KSZ9031RNX

## 3.9.3 RGMII PAD SKEW REGISTERS

Pad skew registers are available for all RGMII pins (clocks, control signals, and data bits) to provide programming options to adjust or correct the timing relationship for each RGMII pin. Because RGMII is a source-synchronous bus interface, the timing relationship needs to be maintained only within the RGMII pin's respective timing group.

- RGMII transmit timing group pins: GTX\_CLK, TX\_EN, TXD[3:0]
- RGMII receive timing group pins: RX\_CLK, RX\_DV, RXD[3:0]

Table 3-4 details the four registers located at MMD Address 2h that are provided for pad skew programming.

**TABLE 3-4: RGMII PAD SKEW REGISTERS**

Address	Name	Description	Mode	Default
<b>MMD Address 2h, Register 4h – RGMII Control Signal Pad Skew</b>				
2.4.15:8	Reserved	Reserved	RW	0000_0000
2.4.7:4	RX_DV Pad Skew	RGMII RX_CTL output pad skew control (0.06 ns/step)	RW	0111
2.4.3:0	TX_EN Pad Skew	RGMII TX_CTL input pad skew control (0.06 ns/step)	RW	0111
<b>MMD Address 2h, Register 5h – RGMII RX Data Pad Skew</b>				
2.5.15:12	RXD3 Pad Skew	RGMII RXD3 output pad skew control (0.06 ns/step)	RW	0111
2.5.11:8	RXD2 Pad Skew	RGMII RXD2 output pad skew control (0.06 ns/step)	RW	0111
2.5.7:4	RXD1 Pad Skew	RGMII RXD1 output pad skew control (0.06 ns/step)	RW	0111
2.5.3:0	RXD0 Pad Skew	RGMII RXD0 output pad skew control (0.06 ns/step)	RW	0111
<b>MMD Address 2h, Register 6h – RGMII TX Data Pad Skew</b>				
2.6.15:12	TXD3 Pad Skew	RGMII TXD3 input pad skew control (0.06 ns/step)	RW	0111
2.6.11:8	TXD2 Pad Skew	RGMII TXD2 input pad skew control (0.06 ns/step)	RW	0111
2.6.7:4	TXD1 Pad Skew	RGMII TXD1 input pad skew control (0.06 ns/step)	RW	0111
2.6.3:0	TXD0 Pad Skew	RGMII TXD0 input pad skew control (0.06 ns/step)	RW	0111
<b>MMD Address 2h, Register 8h – RGMII Clock Pad Skew</b>				
2.8.15:10	Reserved	Reserved	RW	0000_00
2.8.9:5	GTX_CLK Pad Skew	RGMII GTX_CLK input pad skew control (0.06 ns/step)	RW	01_111
2.8.4:0	RX_CLK Pad Skew	RGMII RX_CLK output pad skew control (0.06 ns/step)	RW	0_1111

The RGMII control signals and data bits have 4-bit skew settings, while the RGMII clocks have 5-bit skew settings.

Each register bit is approximately a 0.06 ns step change. A single-bit decrement decreases the delay by approximately 0.06 ns, while a single-bit increment increases the delay by approximately 0.06 ns.

Table 3-5 and Table 3-6 list the approximate delay for each pad skew (value) setting.

**TABLE 3-5: DELAY FOR 5-BIT PAD SKEW SETTING**

Pad Skew Value	Delay (ns)
0_0000	-0.90
0_0001	-0.84
0_0010	-0.78
0_0011	-0.72
0_0100	-0.66
0_0101	-0.60
0_0110	-0.54
0_0111	-0.48
0_1000	-0.42
0_1001	-0.36
0_1010	-0.30
0_1011	-0.24
0_1100	-0.18
0_1101	-0.12
0_1110	-0.06
0_1111	No delay adjustment (default value)
1_0000	+0.06
1_0001	+0.12
1_0010	+0.18
1_0011	+0.24
1_0100	+0.30
1_0101	+0.36
1_0110	+0.42
1_0111	+0.48
1_1000	+0.54
1_1001	+0.60
1_1010	+0.66
1_1011	+0.72
1_1100	+0.78
1_1101	+0.84
1_1110	+0.90
1_1111	+0.96

# KSZ9031RNX

**TABLE 3-6: DELAY FOR 4-BIT PAD SKEW SETTING**

Pad Skew Value	Delay (ns)
0000	-0.42
0001	-0.36
0010	-0.30
0011	-0.24
0100	-0.18
0101	-0.12
0110	-0.06
0111	No delay adjustment (default value)
1000	+0.06
1001	+0.12
1010	+0.18
1011	+0.24
1100	+0.30
1101	+0.36
1110	+0.42
1111	+0.48

When computing the RGMII timing relationships, delays along the entire data path must be aggregated to determine the total delay to be used for comparison between RGMII pins within their respective timing group. For the transmit data path, total delay includes MAC output delay, MAC-to-PHY PCB routing delay, and PHY (KSZ9031RNX) input delay and skew setting (if any). For the receive data path, the total delay includes PHY (KSZ9031RNX) output delay, PHY-to-MAC PCB routing delay, and MAC input delay and skew setting (if any).

As the default, after power-up or reset, the KSZ9031RNX RGMII timing conforms to the timing requirements in the RGMII Version 2.0 Specification for internal PHY chip delay.

For the transmit path (MAC to KSZ9031RNX), the KSZ9031RNX does not add any delay locally at its GTX\_CLK, TX\_EN and TXD[3:0] input pins, and expects the GTX\_CLK delay to be provided on-chip by the MAC. If MAC does not provide any delay or insufficient delay for the GTX\_CLK, the KSZ9031RNX has pad skew registers that can provide up to 1.38 ns on-chip delay.

For the receive path (KSZ9031RNX to MAC), the KSZ9031RNX adds 1.2ns typical delay to the RX\_CLK output pin with respect to RX\_DV and RXD[3:0] output pins. If necessary, the KSZ9031RNX has pad skew registers that can adjust the RX\_CLK on-chip delay up to 2.58 ns from the 1.2 ns default delay.

The above default RGMII timings imply:

- RX\_CLK clock skew is set by the KSZ9031RNX default register settings.
- GTX\_CLK clock skew is provided by the MAC.
- No PCB delay is required for GTX\_CLK and RX\_CLK clocks.

The following examples show how to read/write to MMD Address 2h, Register 8h for the RGMII GTX\_CLK and RX\_CLK skew settings. MMD register access is through the direct portal Registers Dh and Eh. For more programming details, refer to the [MMD Registers](#) section.

- Read back value of MMD Address 2h, Register 8h.
  - Write Register 0xD = 0x0002 // Select MMD Device Address 2h
  - Write Register 0xE = 0x0008 // Select Register 8h of MMD Device Address 2h
  - Write Register 0xD = 0x4002 // Select register data for MMD Device Address 2h, Register 8h
  - Read Register 0xE // Read value of MMD Device Address 2h, Register 8h

- Write value 0x03FF (delay GTX\_CLK and RX\_CLK pad skews to their maximum values) to MMD Address 2h, Register 8h
  - Write Register 0xD = 0x0002 // Select MMD Device Address 2h
  - Write Register 0xE = 0x0008 // Select Register 8h of MMD Device Address 2h
  - Write Register 0xD = 0x4002 // Select register data for MMD Device Address 2h, Register 8h
  - Write Register 0xE = 0x03FF // Write value 0x03FF to MMD Device Address 2h, Register 8h

### 3.9.4 RGMII IN-BAND STATUS

The KSZ9031RNX provides in-band status to the MAC during the inter-frame gap when RX\_DV is de-asserted. RGMII in-band status is always enabled after power-up.

The in-band status is sent to the MAC using the RXD[3:0] data pins, and is described in [Table 3-7](#).

**TABLE 3-7: RGMII IN-BAND STATUS**

RX_DV	RXD3	RXD[2:1]	RXD0
0 (valid only when RX_DV is low)	Duplex Status 0 = Half-duplex 1 = Full-duplex	RX_CLK clock speed 00 = 2.5 MHz (10 Mbps) 01 = 25 MHz (100 Mbps) 10 = 125 MHz (1000 Mbps) 11 = Reserved	Link Status 0 = Link down 1 = Link up

### 3.10 MII Management (MIIM) Interface

The KSZ9031RNX supports the IEEE 802.3 MII management interface, also known as the Management Data Input/Output (MDIO) interface. This interface allows upper-layer devices to monitor and control the state of the KSZ9031RNX. An external device with MIIM capability is used to read the PHY status and/or configure the PHY settings. More details about the MIIM interface can be found in Clause 22.2.4 of the IEEE 802.3 Specification.

The MIIM interface consists of the following:

- A physical connection that incorporates the clock line (MDC) and the data line (MDIO).
- A specific protocol that operates across the physical connection mentioned earlier, which allows an external controller to communicate with one or more KSZ9031RNX devices. Each KSZ9031RNX device is assigned a unique PHY address between 0h and 7h by the PHYAD[2:0] strapping pins.
- A 32-register address space for direct access to IEEE-defined registers and vendor-specific registers, and for indirect access to MMD addresses and registers. See the [Register Map](#) section.

PHY Address 0h is supported as the unique PHY address only; it is not supported as the broadcast PHY address, which allows for a single write command to simultaneously program an identical PHY register for two or more PHY devices (for example, using PHY Address 0h to set Register 0h to a value of 0x1940 to set Bit [11] to a value of one to enable software power-down). Instead, separate write commands are used to program each PHY device.

[Table 3-8](#) shows the MII management frame format for the KSZ9031RNX.

**TABLE 3-8: MII MANAGEMENT FRAME FORMAT FOR THE KSZ9031RNX**

	Preamble	Start of Frame	Read/Write OP Code	PHY Address Bits [4:0]	REG Address Bits [4:0]	TA	Data Bits [15:0]	Idle
<b>Read</b>	32 1's	01	10	00AAA	RRRRR	Z0	DDDDDDDD_DDDDDDDD	Z
<b>Write</b>	32 1's	01	01	00AAA	RRRRR	10	DDDDDDDD_DDDDDDDD	Z

### 3.11 Interrupt (INT\_N)

The INT\_N pin is an optional interrupt signal that is used to inform the external controller that there has been a status update in the KSZ9031RNX PHY register. Bits [15:8] of Register 1Bh are the interrupt control bits that enable and disable the conditions for asserting the INT\_N signal. Bits [7:0] of Register 1Bh are the interrupt status bits that indicate which interrupt conditions have occurred. The interrupt status bits are cleared after reading Register 1Bh.

Bit [14] of Register 1Fh sets the interrupt level to active high or active low. The default is active low.

# KSZ9031RNX

The MII management bus option gives the MAC processor complete access to the KSZ9031RNX control and status registers. Additionally, an interrupt pin eliminates the need for the processor to poll the PHY for status change.

## 3.12 LED Mode

The KSZ9031RNX provides two programmable LED output pins, LED2 and LED1, which are configurable to support two LED modes. The LED mode is configured by the LED\_MODE strap-in (Pin 41). It is latched at power-up/reset and is defined as follows:

- Pull-Up: Single-LED Mode
- Pull-Down: Tri-Color Dual-LED Mode

Each LED output pin can directly drive an LED with a series resistor (typically 220Ω to 470Ω).

### 3.12.1 SINGLE-LED MODE

In single-LED mode, the LED2 pin indicates the link status while the LED1 pin indicates the activity status, as shown in [Table 3-9](#).

**TABLE 3-9: SINGLE-LED MODE - PIN DEFINITION**

LED Pin	Pin State	LED Definition	Link/Activity
LED2	H	OFF	Link Off
	L	ON	Link On (any speed)
LED1	H	OFF	No Activity
	Toggle	Blinking	Activity (RX, TX)

### 3.12.2 TRI-COLOR DUAL-LED MODE

In tri-color dual-LED mode, the link and activity status are indicated by the LED2 pin for 1000BASE-T; by the LED1 pin for 100BASE-TX; and by both LED2 and LED1 pins, working in conjunction, for 10BASE-T. This is summarized in [Table 3-10](#).

**TABLE 3-10: TRI-COLOR DUAL-LED MODE - PIN DEFINITION**

LED Pin (State)		LED Pin (Definition)		Link/Activity
LED2	LED1	LED2	LED1	
H	H	OFF	OFF	Link Off
L	H	ON	OFF	1000 Link/No Activity
Toggle	H	Blinking	OFF	1000 Link/Activity (RX, TX)
H	L	OFF	ON	100 Link/No Activity
H	Toggle	OFF	Blinking	100 Link/Activity (RX, TX)
L	L	ON	ON	10 Link/No Activity
Toggle	Toggle	Blinking	Blinking	10 Link/Activity (RX, TX)

## 3.13 Loopback Mode

The KSZ9031RNX supports the following loopback operations to verify analog and/or digital data paths.

- Local (digital) loopback
- Remote (analog) loopback

### 3.13.1 LOCAL (DIGITAL) LOOPBACK

This loopback mode checks the RGMII transmit and receive data paths between KSZ9031RNX and external MAC, and is supported for all three speeds (10/100/1000 Mbps) at full-duplex.

The loopback data path is shown in [Figure 3-5](#).

1. RGMII MAC transmits frames to KSZ9031RNX.
2. Frames are wrapped around inside KSZ9031RNX.
3. KSZ9031RNX transmits frames back to RGMII MAC.

**FIGURE 3-5: LOCAL (DIGITAL) LOOPBACK**

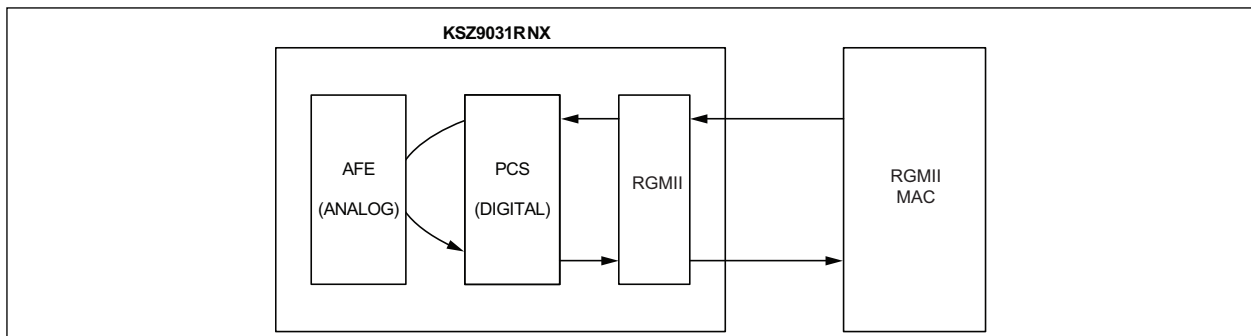

The following programming steps and register settings are used for local loopback mode.

For 1000 Mbps loopback,

1. Set Register 0h,
  - Bit [14] = 1 // Enable local loopback mode
  - Bits [6, 13] = 10 // Select 1000 Mbps speed
  - Bit [12] = 0 // Disable auto-negotiation
  - Bit [8] = 1 // Select full-duplex mode
2. Set Register 9h,
  - Bit [12] = 1 // Enable master-slave manual configuration
  - Bit [11] = 0 // Select slave configuration (required for loopback mode)

For 10/100 Mbps loopback,

1. Set Register 0h,
  - Bit [14] = 1 // Enable local loopback mode
  - Bits [6, 13] = 00 / 01 // Select 10 Mbps/100 Mbps speed
  - Bit [12] = 0 // Disable auto-negotiation
  - Bit [8] = 1 // Select full-duplex mode

### 3.13.2 REMOTE (ANALOG) LOOPBACK

This loopback mode checks the line (differential pairs, transformer, RJ-45 connector, Ethernet cable) transmit and receive data paths between KSZ9031RNX and its link partner, and is supported for 1000BASE-T full-duplex mode only.

The loopback data path is shown in [Figure 3-6](#).

1. The Gigabit PHY link partner transmits frames to KSZ9031RNX.
2. Frames are wrapped around inside KSZ9031RNX.
3. KSZ9031RNX transmits frames back to the Gigabit PHY link partner.

# KSZ9031RNX

**FIGURE 3-6: REMOTE (ANALOG) LOOPBACK**

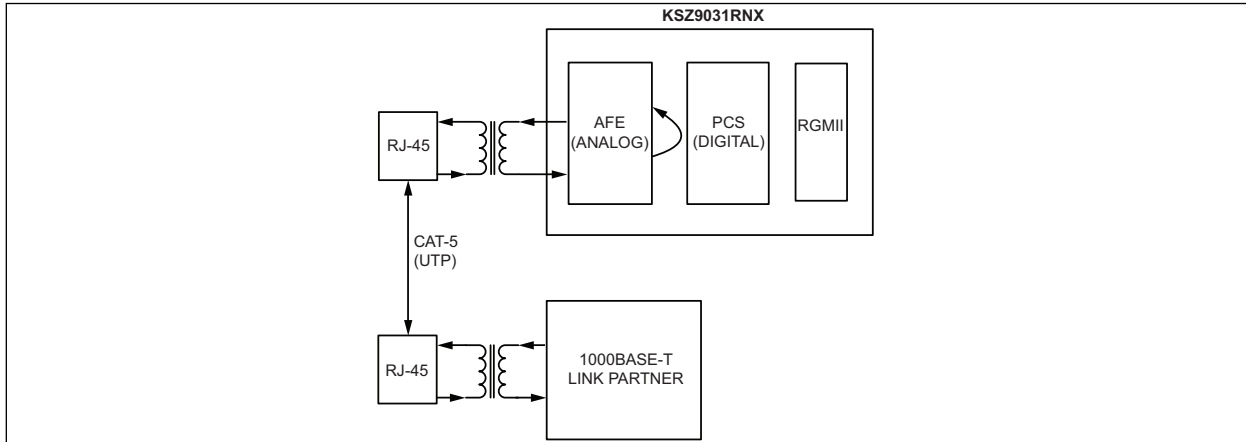

The following programming steps and register settings are used for remote loopback mode.

1. Set Register 0h,
  - Bits [6, 13] = 10 // Select 1000 Mbps speed
  - Bit [12] = 0 // Disable auto-negotiation
  - Bit [8] = 1 // Select full-duplex mode
 Or just auto-negotiate and link up at 1000BASE-T full-duplex mode with the link partner.
2. Set Register 11h,
  - Bit [8] = 1 // Enable remote loopback mode

### 3.14 LinkMD<sup>®</sup> Cable Diagnostic

The LinkMD function uses Time Domain Reflectometry (TDR) to analyze the cabling plant for common cabling problems, such as open circuits, short circuits, and impedance mismatches.

LinkMD operates by sending a pulse of known amplitude and duration down the selected differential pair, then analyzing the polarity and shape of the reflected signal to determine the type of fault: open circuit for a positive/non-inverted amplitude reflection and short circuit for a negative/inverted amplitude reflection. The time duration for the reflected signal to return provides the approximate distance to the cabling fault. The LinkMD function processes this TDR information and presents it as a numerical value that can be translated to a cable distance.

LinkMD is initiated by accessing Register 12h, the LinkMD Cable Diagnostic register, in conjunction with Register 1Ch, the Auto MDI/MDI-X register. The latter register is needed to disable the Auto MDI/MDI-X function before running the LinkMD test. Additionally, a software reset (Reg. 0h, Bit [15] = 1) should be performed before and after running the LinkMD test. The reset helps to ensure the KSZ9031RNX is in the normal operating state before and after the test.

### 3.15 NAND Tree Support

The KSZ9031RNX provides parametric NAND tree support for fault detection between chip I/Os and board. NAND tree mode is enabled at power-up/reset with the MODE[3:0] strap-in pins set to '0100'. [Table 3-11](#) lists the NAND tree pin order.

**TABLE 3-11: NAND TREE TEST PIN ORDER FOR KSZ9031RNX**

Pin	Description
LED2	Input
LED1/PME_N1	Input
TXD0	Input
TXD1	Input
TXD2	Input
TXD3	Input

**TABLE 3-11: NAND TREE TEST PIN ORDER FOR KSZ9031RNX (CONTINUED)**

Pin	Description
GTX_CLK	Input
TX_EN	Input
RX_DV	Input
RX_CLK	Input
INT_/PME_N2	Input
MDC	Input
MDIO	Input
CLK125_NDO	Output

## 3.16 Power Management

The KSZ9031RNX incorporates a number of power-management modes and features that provide methods to consume less energy. These are discussed in the following sections.

### 3.16.1 ENERGY-DETECT POWER-DOWN MODE

Energy-detect power-down (EDPD) mode is used to further reduce the transceiver power consumption when the cable is unplugged. It is enabled by writing a one to MMD Address 1Ch, Register 23h, Bit [0], and is in effect when auto-negotiation mode is enabled and the cable is disconnected (no link).

In EDPD Mode, the KSZ9031RNX shuts down all transceiver blocks, except for the transmitter and energy detect circuits. Power can be reduced further by extending the time interval between the transmissions of link pulses to check for the presence of a link partner. The periodic transmission of link pulses is needed to ensure the KSZ9031RNX and its link partner, when operating in the same low-power state and with Auto MDI/MDI-X disabled, can wake up when the cable is connected between them. By default, EDPD mode is disabled after power-up.

### 3.16.2 SOFTWARE POWER-DOWN MODE

This mode is used to power down the KSZ9031RNX device when it is not in use after power-up. Software power-down (SPD) mode is enabled by writing a one to Register 0h, Bit [11]. In the SPD state, the KSZ9031RNX disables all internal functions, except for the MII management interface. The KSZ9031RNX exits the SPD state after a zero is written to Register 0h, Bit [11].

### 3.16.3 CHIP POWER-DOWN MODE

This mode provides the lowest power state for the KSZ9031RNX device when it is mounted on the board but not in use. Chip power-down (CPD) mode is enabled after power-up/reset with the MODE[3:0] strap-in pins set to '0111'. The KSZ9031RNX exits CPD mode after a hardware reset is applied to the RESET\_N pin (Pin 42) with the MODE[3:0] strap-in pins set to an operating mode other than CPD.

## 3.17 Wake-On-LAN

Wake-On-LAN (WOL) is normally a MAC-based function to wake up a host system (for example, an Ethernet end device, such as a PC) that is in standby power mode. Wake-up is triggered by receiving and detecting a special packet (commonly referred to as the "magic packet") that is sent by the remote link partner. The KSZ9031RNX can perform the same WOL function if the MAC address of its associated MAC device is entered into the KSZ9031RNX PHY registers for magic-packet detection. When the KSZ9031RNX detects the magic packet, it wakes up the host by driving its power management event (PME) output pin low.

By default, the WOL function is disabled. It is enabled by setting the enabling bit and configuring the associated registers for the selected PME wake-up detection method.

The KSZ9031RNX provides three methods to trigger a PME wake-up:

- Magic-packet detection
- Customized-packet detection
- Link status change detection

# KSZ9031RNX

---

## 3.17.1 MAGIC-PACKET DETECTION

The magic packet's frame format starts with 6 bytes of 0xFFh and is followed by 16 repetitions of the MAC address of its associated MAC device (local MAC device).

When the magic packet is detected from its link partner, the KSZ9031RNX asserts its PME output pin low.

The following MMD Address 2h registers are provided for magic-packet detection:

- Magic-packet detection is enabled by writing a '1' to MMD Address 2h, Register 10h, Bit [6]
- The MAC address (for the local MAC device) is written to and stored in MMD Address 2h, Registers 11h – 13h

The KSZ9031RNX does not generate the magic packet. The magic packet must be provided by the external system.

## 3.17.2 CUSTOMIZED-PACKET DETECTION

The customized packet has associated register/bit masks to select which byte, or bytes, of the first 64 bytes of the packet to use in the CRC calculation. After the KSZ9031RNX receives the packet from its link partner, the selected bytes for the received packet are used to calculate the CRC. The calculated CRC is compared to the expected CRC value that was previously written to and stored in the KSZ9031RNX PHY registers. If there is a match, the KSZ9031RNX asserts its PME output pin low.

Four customized packets are provided to support four types of wake-up scenarios. A dedicated set of registers is used to configure and enable each customized packet.

The following MMD registers are provided for customized-packet detection:

- Each of the four customized packets is enabled via MMD Address 2h, Register 10h,
  - Bit [2] // For customized packets, type 0
  - Bit [3] // For customized packets, type 1
  - Bit [4] // For customized packets, type 2
  - Bit [5] // For customized packets, type 3
- 32-bit expected CRCs are written to and stored in:
  - MMD Address 2h, Registers 14h – 15h // For customized packets, type 0
  - MMD Address 2h, Registers 16h – 17h // For customized packets, type 1
  - MMD Address 2h, Registers 18h – 19h // For customized packets, type 2
  - MMD Address 2h, Registers 1Ah – 1Bh // For customized packets, type 3
- Masks to indicate which of the first 64-bytes to use in the CRC calculation are set in:
  - MMD Address 2h, Registers 1Ch – 1Fh // For customized packets, type 0
  - MMD Address 2h, Registers 20h – 23h // For customized packets, type 1
  - MMD Address 2h, Registers 24h – 27h // For customized packets, type 2
  - MMD Address 2h, Registers 28h – 2Bh // For customized packets, type 3

### 3.17.3 LINK STATUS CHANGE DETECTION

If link status change detection is enabled, the KSZ9031RNX asserts its PME output pin low whenever there is a link status change using the following MMD Address 2h registers bits and their enabled (1) or disabled (0) settings:

- MMD Address 2h, Register 10h, Bit [0] // For link-up detection
- MMD Address 2h, Register 10h, Bit [1] // For link-down detection

The PME output signal is available on either LED1/PME\_N1 (Pin 17) or INT\_N/PME\_N2 (Pin 38), and is selected and enabled using MMD Address 2h, Register 2h, Bits [8] and [10], respectively. Additionally, MMD Address 2h, Register 10h, Bits [15:14] defines the output functions for Pins 17 and 38.

The PME output is active low and requires a 1 kΩ pull-up to the VDDIO supply. When asserted, the PME output is cleared by disabling the register bit that enabled the PME trigger source (magic packet, customized packet, link status change).

### 3.18 Typical Current/Power Consumption

Table 3-12, Table 3-13, Table 3-14, and Table 3-15 show the typical current consumption by the core (DVDDL, AVDDL, AVDDL\_PLL), transceiver (AVDDH), and digital I/O (DVDDH) supply pins, and the total typical power for the entire KSZ9031RNX device for various nominal operating voltage combinations.

**TABLE 3-12: TYPICAL CURRENT/POWER CONSUMPTION  
TRANSCEIVER (3.3V), DIGITAL I/O (3.3V)**

Condition	1.2V Core (DVDDL, AVDDL, AVDDL_PLL)	3.3V Transceiver (AVDDH)	3.3V Digital I/O (DVDDH)	Total Chip Power
1000BASE-T Link-Up (no traffic)	210 mA	67.4 mA	19.5 mA	538 mW
1000BASE-T Full-Duplex at 100% Utilization	221 mA	66.3 mA	41.5 mA	621 mW
100BASE-TX Link-Up (no traffic)	63.6 mA	28.7 mA	13.9 mA	217 mW
100BASE-TX Full-Duplex at 100% Utilization	63.8 mA	28.6 mA	17.2 mA	228 mW
10BASE-T Link-Up (no traffic)	7.1 mA	15.9 mA	11.5 mA	99 mW
10BASE-T Full-Duplex at 100% Utilization	7.7 mA	28.6 mA	13.7 mA	149 mW
Software Power-Down Mode (Reg. 0h.11 = 1)	1.0 mA	4.2 mA	9.3 mA	46 mW

**TABLE 3-13: TYPICAL CURRENT/POWER CONSUMPTION  
TRANSCEIVER (3.3V), DIGITAL I/O (1.8V)**

Condition	1.2V Core (DVDDL, AVDDL, AVDDL_PLL)	3.3V Transceiver (AVDDH)	1.8V Digital I/O (DVDDH)	Total Chip Power
1000BASE-T Link-Up (no traffic)	210 mA	67.4 mA	11.2 mA	494 mW
1000BASE-T Full-Duplex at 100% Utilization	221 mA	66.3 mA	23.6 mA	526 mW
100BASE-TX Link-Up (no traffic)	63.6 mA	28.7 mA	8.4 mA	186 mW
100BASE-TX Full-Duplex at 100% Utilization	63.8 mA	28.6 mA	9.8 mA	189 mW
10BASE-T Link-Up (no traffic)	7.1 mA	15.9 mA	3.6 mA	67 mW
10BASE-T Full-Duplex at 100% Utilization	7.7 mA	28.6 mA	5.6 mA	114 mW
Software Power-Down Mode (Reg. 0h.11 = 1)	1.0 mA	4.2 mA	5.5 mA	25 mW

# KSZ9031RNX

**TABLE 3-14: TYPICAL CURRENT/POWER CONSUMPTION  
TRANSCEIVER (2.5V; [Note 3-1](#)), DIGITAL I/O (2.5V)**

Condition	1.2V Core (DVDDL, AVDDL, AVDDL_PLL)	2.5V Transceiver (AVDDH)	2.5V Digital I/O (DVDDH)	Total Chip Power
1000BASE-T Link-Up (no traffic)	210 mA	58.8 mA	14.7 mA	435 mW
1000BASE-T Full-Duplex at 100% Utilization	221 mA	57.9 mA	31.5 mA	488 mW
100BASE-TX Link-Up (no traffic)	63.6 mA	24.9 mA	10.5 mA	165 mW
100BASE-TX Full-Duplex at 100% Utilization	63.8 mA	24.9 mA	13.0 mA	171 mW
10BASE-T Link-Up (no traffic)	7.1 mA	11.5 mA	6.3 mA	53 mW
10BASE-T Full-Duplex at 100% Utilization	7.7 mA	25.3 mA	9.0 mA	95 mW
Software Power-Down Mode (Reg. 0h.11 = 1)	1.0 mA	3.1 mA	6.7 mA	26 mW

**Note 3-1** 2.5V AVDDH is recommended for commercial temperature range (0°C to +70°C) operation only.

**TABLE 3-15: TYPICAL CURRENT/POWER CONSUMPTION  
TRANSCEIVER (2.5V; [Note 3-2](#)), DIGITAL I/O (1.8V)**

Condition	1.2V Core (DVDDL, AVDDL, AVDDL_PLL)	2.5V Transceiver (AVDDH)	1.8V Digital I/O (DVDDH)	Total Chip Power
1000BASE-T Link-Up (no traffic)	210 mA	58.8 mA	11.2 mA	419 mW
1000BASE-T Full-Duplex at 100% Utilization	221 mA	57.9 mA	23.6 mA	452 mW
100BASE-TX Link-Up (no traffic)	63.6 mA	24.9 mA	8.4 mA	154 mW
100BASE-TX Full-Duplex at 100% Utilization	63.8 mA	24.9 mA	9.8 mA	156 mW
10BASE-T Link-Up (no traffic)	7.1 mA	11.5 mA	3.6 mA	44 mW
10BASE-T Full-Duplex at 100% Utilization	7.7 mA	25.3 mA	5.6 mA	83 mW
Software Power-Down Mode (Reg. 0h.11 = 1)	1.0 mA	3.1 mA	5.5 mA	19 mW

**Note 3-2** 2.5V AVDDH is recommended for commercial temperature range (0°C to +70°C) operation only.

## 4.0 REGISTER DESCRIPTIONS

This chapter describes the various control and status registers (CSRs).

### 4.1 Register Map

The register space within the KSZ9031RNX consists of two distinct areas.

- Standard registers // Direct register access
- MDIO Manageable device (MMD) registers // Indirect register access

The KSZ9031RNX supports the following standard registers.

**TABLE 4-1: STANDARD REGISTERS SUPPORTED BY KSZ9031RNX**

Register Number (hex)	Description
<b>IEEE-Defined Registers</b>	
0h	Basic Control
1h	Basic Status
2h	PHY Identifier 1
3h	PHY Identifier 2
4h	Auto-Negotiation Advertisement
5h	Auto-Negotiation Link Partner Ability
6h	Auto-Negotiation Expansion
7h	Auto-Negotiation Next Page
8h	Auto-Negotiation Link Partner Next Page Ability
9h	1000BASE-T Control
Ah	1000BASE-T Status
Bh - Ch	Reserved
Dh	MMD Access – Control
Eh	MMD Access – Register/Data
Fh	Extended Status
<b>Vendor-Specific Registers</b>	
10h	Reserved
11h	Remote Loopback
12h	LinkMD Cable Diagnostic
13h	Digital PMA/PCS Status
14h	Reserved
15h	RXER Counter
16h - 1Ah	Reserved
1Bh	Interrupt Control/Status
1Ch	Auto MDI/MDI-X
1Dh - 1Eh	Reserved
1Fh	PHY Control

The KSZ9031RNX supports the following MMD device addresses and their associated register addresses, which make up the indirect MMD registers. These can be seen in [Table 4-2](#).

# KSZ9031RNX

**TABLE 4-2: MMD REGISTERS SUPPORTED BY KSZ9031RNX**

Device Address (hex)	Register Address (hex)	Description
0h	3h	AN FLP Burst Transmit – LO
	4h	AN FLP Burst Transmit – HI
1h	5Ah	1000BASE-T Link-Up Time Control
2h	0h	Common Control
	1h	Strap Status
	2h	Operation Mode Strap Override
	3h	Operation Mode Strap Status
	4h	RGMII Control Signal Pad Skew
	5h	RGMII RX Data Pad Skew
	6h	RGMII TX Data Pad Skew
	8h	GMII Clock Pad Skew
	10h	Wake-On-LAN – Control
	11h	Wake-On-LAN – Magic Packet, MAC-DA-0
	12h	Wake-On-LAN – Magic Packet, MAC-DA-1
	13h	Wake-On-LAN – Magic Packet, MAC-DA-2
	14h	Wake-On-LAN – Customized Packet, Type 0, Expected CRC 0
	15h	Wake-On-LAN – Customized Packet, Type 0, Expected CRC 1
	16h	Wake-On-LAN – Customized Packet, Type 1, Expected CRC 0
	17h	Wake-On-LAN – Customized Packet, Type 1, Expected CRC 1
	18h	Wake-On-LAN – Customized Packet, Type 2, Expected CRC 0
	19h	Wake-On-LAN – Customized Packet, Type 2, Expected CRC 1
	1Ah	Wake-On-LAN – Customized Packet, Type 3, Expected CRC 0
	1Bh	Wake-On-LAN – Customized Packet, Type 3, Expected CRC 1
	1Ch	Wake-On-LAN – Customized Packet, Type 0, Mask 0
	1Dh	Wake-On-LAN – Customized Packet, Type 0, Mask 1
	1Eh	Wake-On-LAN – Customized Packet, Type 0, Mask 2
1Fh	Wake-On-LAN – Customized Packet, Type 0, Mask 3	
20h	Wake-On-LAN – Customized Packet, Type 1, Mask 0	
21h	Wake-On-LAN – Customized Packet, Type 1, Mask 1	
22h	Wake-On-LAN – Customized Packet, Type 1, Mask 2	
23h	Wake-On-LAN – Customized Packet, Type 1, Mask 3	

**TABLE 4-2: MMD REGISTERS SUPPORTED BY KSZ9031RNX (CONTINUED)**

Device Address (hex)	Register Address (hex)	Description
2h	24h	Wake-On-LAN – Customized Packet, Type 2, Mask 0
	25h	Wake-On-LAN – Customized Packet, Type 2, Mask 1
	26h	Wake-On-LAN – Customized Packet, Type 2, Mask 2
	27h	Wake-On-LAN – Customized Packet, Type 2, Mask 3
	28h	Wake-On-LAN – Customized Packet, Type 3, Mask 0
	29h	Wake-On-LAN – Customized Packet, Type 3, Mask 1
	2Ah	Wake-On-LAN – Customized Packet, Type 3, Mask 2
	2Bh	Wake-On-LAN – Customized Packet, Type 3, Mask 3
1Ch	4h	Analog Control 4
	23h	EDPD Control

## 4.2 Standard Registers

Standard registers provide direct read/write access to a 32-register address space, as defined in Clause 22 of the IEEE 802.3 Specification. Within this address space, the first 16 registers (Registers 0h to Fh) are defined according to the IEEE specification, while the remaining 16 registers (Registers 10h to 1Fh) are defined specific to the PHY vendor.

**TABLE 4-3: IEEE-DEFINED REGISTER DESCRIPTIONS**

Address	Name	Description	Mode <a href="#">Note 4-1</a>	Default
<b>Register 0h – Basic Control</b>				
0.15	Reset	1 = Software PHY reset 0 = Normal operation This bit is self-cleared after a '1' is written to it.	RW/SC	0
0.14	Loopback	1 = Loopback mode 0 = Normal operation	RW	0
0.13	Speed Select (LSB)	[0.6, 0.13] [1,1] = Reserved [1,0] = 1000 Mbps [0,1] = 100 Mbps [0,0] = 10 Mbps This bit is ignored if auto-negotiation is enabled (Reg. 0.12 = 1).	RW	0
0.12	Auto-Negotiation Enable	1 = Enable auto-negotiation process 0 = Disable auto-negotiation process If enabled, auto-negotiation result overrides settings in Reg. 0.13, 0.8 and 0.6. If disabled, Auto MDI-X is also automatically disabled. Use Register 1Ch to set MDI/MDI-X.	RW	1
0.11	Power-Down	1 = Power-down mode 0 = Normal operation When this bit is set to '1', the link-down status might not get updated in the PHY register. Software should note link is down and should not rely on the PHY register link status. After this bit is changed from '1' to '0', an internal global reset is automatically generated. Wait a minimum of 1 ms before read/write access to the PHY registers.	RW	0

# KSZ9031RNX

**TABLE 4-3: IEEE-DEFINED REGISTER DESCRIPTIONS (CONTINUED)**

Address	Name	Description	Mode Note 4-1	Default
0.10	Isolate	1 = Electrical isolation of PHY from RGMII 0 = Normal operation	RW	0
0.9	Restart Auto-Negotiation	1 = Restart auto-negotiation process 0 = Normal operation This bit is self-cleared after a '1' is written to it.	RW/SC	0
0.8	Duplex Mode	1 = Full-duplex 0 = Half-duplex	RW	1
0.7	Reserved	Reserved	RW	0
0.6	Speed Select (MSB)	[0.6, 0.13] [1,1] = Reserved [1,0] = 1000 Mbps [0,1] = 100 Mbps [0,0] = 10 Mbps This bit is ignored if auto-negotiation is enabled (Reg. 0.12 = 1).	RW	Set by MODE[3:0] strapping pins. See the <a href="#">Strap-In Options - KSZ9031RNX</a> section for details.
0.5:0	Reserved	Reserved	RO	00_0000
<b>Register 1h - Basic Status</b>				
1.15	100BASE-T4	1 = T4 capable 0 = Not T4 capable	RO	0
1.14	100BASE-TX Full-Duplex	1 = Capable of 100 Mbps full-duplex 0 = Not capable of 100 Mbps full-duplex	RO	1
1.13	100BASE-TX Half-Duplex	1 = Capable of 100 Mbps half-duplex 0 = Not capable of 100 Mbps half-duplex	RO	1
1.12	10BASE-T Full-Duplex	1 = Capable of 10 Mbps full-duplex 0 = Not capable of 10 Mbps full-duplex	RO	1
1.11	10BASE-T Half-Duplex	1 = Capable of 10 Mbps half-duplex 0 = Not capable of 10 Mbps half-duplex	RO	1
1.10:9	Reserved	Reserved	RO	00
1.8	Extended Status	1 = Extended status info in Reg. 15h. 0 = No extended status info in Reg. 15h.	RO	1
1.7	Reserved	Reserved	RO	0
1.6	No Preamble	1 = Preamble suppression 0 = Normal preamble	RO	1
1.5	Auto-Negotiation Complete	1 = Auto-negotiation process completed 0 = Auto-negotiation process not completed	RO	0
1.4	Remote Fault	1 = Remote fault 0 = No remote fault	RO/LH	0
1.3	Auto-Negotiation Ability	1 = Can perform auto-negotiation 0 = Cannot perform auto-negotiation	RO	1
1.2	Link Status	1 = Link is up 0 = Link is down	RO/LL	0
1.1	Jabber Detect	1 = Jabber detected 0 = Jabber not detected (default is low)	RO/LH	0
1.0	Extended Capability	1 = Supports extended capability registers	RO	1
<b>Register 2h - PHY Identifier 1</b>				

**TABLE 4-3: IEEE-DEFINED REGISTER DESCRIPTIONS (CONTINUED)**

Address	Name	Description	Mode Note 4-1	Default
2.15:0	PHY ID Number	Assigned to Bits [3:18] of the organizationally unique identifier (OUI). KENDIN Communication's OUI is 0010A1h.	RO	0022h
<b>Register 3h - PHY Identifier 2</b>				
3.15:10	PHY ID Number	Assigned to Bits [19:24] of the organizationally unique identifier (OUI). KENDIN Communication's OUI is 0010A1h.	RO	0001_01
3.9:4	Model Number	Six-bit manufacturer's model number	RO	10_0010
3.3:0	Revision Number	Four-bit manufacturer's revision number	RO	Indicates silicon revision
<b>Register 4h - Auto-Negotiation Advertisement</b>				
4.15	Next Page	1 = Next page capable 0 = No next page capability	RW	0
4.14	Reserved	Reserved	RO	0
4.13	Remote Fault	1 = Remote fault supported 0 = No remote fault	RW	0
4.12	Reserved	Reserved	RO	0
4.11:10	Pause	[4.11, 4.10] [0,0] = No pause [1,0] = Asymmetric pause (link partner) [0,1] = Symmetric pause [1,1] = Symmetric and asymmetric pause (local device)	RW	00
4.9	100BASE-T4	1 = T4 capable 0 = No T4 capability	RO	0
4.8	100BASE-TX Full-Duplex	1 = 100 Mbps full-duplex capable 0 = No 100 Mbps full-duplex capability	RW	1
4.7	100BASE-TX Half-Duplex	1 = 100 Mbps half-duplex capable 0 = No 100 Mbps half-duplex capability	RW	1
4.6	10BASE-T Full-Duplex	1 = 10 Mbps full-duplex capable 0 = No 10 Mbps full-duplex capability	RW	1
4.5	10BASE-T Half-Duplex	1 = 10 Mbps half-duplex capable 0 = No 10 Mbps half-duplex capability	RW	1
4.4:0	Selector Field	[00001] = IEEE 802.3	RW	0_0001
<b>Register 5h - Auto-Negotiation Link Partner Ability</b>				
5.15	Next Page	1 = Next page capable 0 = No next page capability	RO	0
5.14	Acknowledge	1 = Link code word received from partner 0 = Link code word not yet received	RO	0
5.13	Remote Fault	1 = Remote fault detected 0 = No remote fault	RO	0
5.12	Reserved	Reserved	RO	0

# KSZ9031RNX

**TABLE 4-3: IEEE-DEFINED REGISTER DESCRIPTIONS (CONTINUED)**

Address	Name	Description	Mode Note 4-1	Default
5.11:10	Pause	[5.11, 5.10] [0,0] = No pause [1,0] = Asymmetric Pause (link partner) [0,1] = Symmetric pause [1,1] = Symmetric and asymmetric pause (local device)	RW	00
5.9	100BASE-T4	1 = T4 capable 0 = No T4 capability	RO	0
5.8	100BASE-TX Full-Duplex	1 = 100 Mbps full-duplex capable 0 = No 100 Mbps full-duplex capability	RO	0
5.7	100BASE-TX Half-Duplex	1 = 100 Mbps half-duplex capable 0 = No 100 Mbps half-duplex capability	RO	0
5.6	10BASE-T Full-Duplex	1 = 10 Mbps full-duplex capable 0 = No 10 Mbps full-duplex capability	RO	0
5.5	10BASE-T Half-Duplex	1 = 10 Mbps half-duplex capable 0 = No 10 Mbps half-duplex capability	RO	0
5.4:0	Selector Field	[00001] = IEEE 802.3	RO	0_0000
<b>Register 6h - Auto-Negotiation Expansion</b>				
6.15:5	Reserved	Reserved	RO	0000_0000_000
6.4	Parallel Detection Fault	1 = Fault detected by parallel detection 0 = No fault detected by parallel detection	RO/LH	0
6.3	Link Partner Next Page Able	1 = Link partner has next page capability 0 = Link partner does not have next page capability	RO	0
6.2	Next Page Able	1 = Local device has next page capability 0 = Local device does not have next page capability	RO	1
6.1	Page Received	1 = New page received 0 = New page not received	RO/LH	0
6.0	Link Partner Auto-Negotiation Able	1 = Link partner has auto-negotiation capability 0 = Link partner does not have auto-negotiation capability	RO	0
<b>Register 7h - Auto-Negotiation Next Page</b>				
7.15	Next Page	1 = Additional next pages will follow 0 = Last page	RW	0
7.14	Reserved	Reserved	RO	0
7.13	Message Page	1 = Message page 0 = Unformatted page	RW	1
7.12	Acknowledge2	1 = Will comply with message 0 = Cannot comply with message	RW	0
7.11	Toggle	1 = Previous value of the transmitted link code word equaled logic one 0 = Logic zero	RO	0
7.10:0	Message Field	11-bit wide field to encode 2048 messages	RW	000_0000_0001
<b>Register 8h - Link Partner Next Page Ability</b>				

**TABLE 4-3: IEEE-DEFINED REGISTER DESCRIPTIONS (CONTINUED)**

Address	Name	Description	Mode Note 4-1	Default
8.15	Next Page	1 = Additional next pages will follow 0 = Last page	RO	0
8.14	Acknowledge	1 = Successful receipt of link word 0 = No successful receipt of link word	RO	0
8.13	Message Page	1 = Message page 0 = Unformatted page	RO	0
8.12	Acknowledge2	1 = Able to act on the information 0 = Not able to act on the information	RO	0
8.11	Toggle	1 = Previous value of transmitted link code word equal to logic zero 0 = Previous value of transmitted link code word equal to logic one	RO	0
8.10:0	Message Field	—	RO	000_0000_0000
<b>Register 9h – 1000BASE-T Control</b>				
9.15:13	Test Mode Bits	Transmitter test mode operations [9.15:13] Mode [000] Normal operation [001] Test mode 1 –Transmit waveform test [010] Test mode 2 –Transmit jitter test in master mode [011] Test mode 3 –Transmit jitter test in slave mode [100] Test mode 4 –Transmitter distortion test [101] Reserved, operations not identified [110] Reserved, operations not identified [111] Reserved, operations not identified To enable 1000BASE-T Test Mode: 1) Set Register 0h = 0x0140 to disable auto-negotiation and select 1000 Mbps speed. 2) Set Register 9h, bits [15:13] = 001, 010, 011, or 100 to select one of the 1000BASE-T Test Modes. After the above settings, the test waveform for the selected test mode is transmitted onto each of the 4 differential pairs. No link partner is needed.	RW	000
9.12	Master-Slave Manual Configuration Enable	1 = Enable master-slave manual configuration value 0 = Disable master-slave manual configuration value	RW	0
9.11	Master-Slave Manual Configuration Value	1 = Configure PHY as master during master-slave negotiation 0 = Configure PHY as slave during master-slave negotiation This bit is ignored if master-slave manual configuration is disabled (Reg. 9.12 = 0).	RW	0
9.10	Port Type	1 = Indicate the preference to operate as multi-port device (master) 0 = Indicate the preference to operate as single-port device (slave) This bit is valid only if master-slave manual configuration is disabled (Reg. 9.12 = 0).	RW	0

# KSZ9031RNX

**TABLE 4-3: IEEE-DEFINED REGISTER DESCRIPTIONS (CONTINUED)**

Address	Name	Description	Mode Note 4-1	Default
9.9	1000BASE-T Full-Duplex	1 = Advertise PHY is 1000BASE-T full-duplex capable 0 = Advertise PHY is not 1000BASE-T full-duplex capable	RW	1
9.8	1000BASE-T Half-Duplex	1 = Advertise PHY is 1000BASE-T half-duplex capable 0 = Advertise PHY is not 1000BASE-T half-duplex capable	RW	Set by MODE[3:0] strapping pins. See the <a href="#">Strap-In Options - KSZ9031RNX</a> section for details.
9.7:0	Reserved	Write as 0, ignore on read	RO	—
<b>Register Ah – 1000BASE-T Status</b>				
A.15	Master-Slave Configuration Fault	1 = Master-slave configuration fault detected 0 = No master-slave configuration fault detected	RO/LH/SC	0
A.14	Master-Slave Configuration Resolution	1 = Local PHY configuration resolved to master 0 = Local PHY configuration resolved to slave	RO	0
A.13	Local Receiver Status	1 = Local receiver OK (loc_rcvr_status = 1) 0 = Local receiver not OK (loc_rcvr_status = 0)	RO	0
A.12	Remote Receiver Status	1 = Remote receiver OK (rem_rcvr_status = 1) 0 = Remote receiver not OK (rem_rcvr_status = 0)	RO	0
A.11	Link Partner 1000BASE-T Full-Duplex Capability	1 = Link partner is capable of 1000BASE-T full-duplex 0 = Link partner is not capable of 1000BASE-T full-duplex	RO	0
A.10	Link Partner 1000BASE-T Half-Duplex Capability	1 = Link partner is capable of 1000BASE-T half-duplex 0 = Link Partner is not capable of 1000BASE-T half-duplex	RO	0
A.9:8	Reserved	Reserved	RO	00
A.7:0	Idle Error Count	Cumulative count of errors detected when receiver is receiving idles and PMA_TXMODE.indicate = SEND_N. The counter is incremented every symbol period that rxerror_status = ERROR.	RO/SC	0000_0000
<b>Register Dh - MMD Access – Control</b>				
D.15:14	MMD – Operation Mode	For the selected MMD device address (Bits [4:0] of this register), these two bits select one of the following register or data operations and the usage for MMD Access – Register/Data (Reg. Eh). 00 = Register 01 = Data, no post increment 10 = Data, post increment on reads and writes 11 = Data, post increment on writes only	RW	00
D.13:5	Reserved	Reserved	RW	00_0000_000

**TABLE 4-3: IEEE-DEFINED REGISTER DESCRIPTIONS (CONTINUED)**

Address	Name	Description	Mode Note 4-1	Default
D.4:0	MMD – Device Address	These five bits set the MMD device address.	RW	0_0000
<b>Register Eh - MMD Access – Register/Data</b>				
E.15:0	MMD – Register/Data	For the selected MMD device address (Reg. Dh, Bits [4:0]), When Reg. Dh, Bits [15:14] = 00, this register contains the read/write register address for the MMD device address. Otherwise, this register contains the read/write data value for the MMD device address and its selected register address. See also Reg. Dh, Bits [15:14], for descriptions of post increment reads and writes of this register for data operation.	RW	0000_0000_0000_0000
<b>Register Fh – Extended Status</b>				
F.15	1000BASE-X Full-Duplex	1 = PHY can perform 1000BASE-X full-duplex 0 = PHY cannot perform 1000BASE-X full-duplex	RO	0
F.14	1000BASE-X Half-Duplex	1 = PHY can perform 1000BASE-X half-duplex 0 = PHY cannot perform 1000BASE-X half-duplex	RO	0
F.13	1000BASE-T Full-Duplex	1 = PHY can perform 1000BASE-T full-duplex 0 = PHY cannot perform 1000BASE-T full-duplex	RO	1
F.12	1000BASE-T Half-Duplex	1 = PHY can perform 1000BASE-T half-duplex 0 = PHY cannot perform 1000BASE-T half-duplex	RO	1
F.11:0	Reserved	Ignore when read	RO	—

**Note 4-1** RW = Read/Write; RO = Read Only; SC = Self-Cleared; LH = Latch High; LL = Latch Low.

**TABLE 4-4: VENDOR-SPECIFIC REGISTER DESCRIPTIONS**

Address	Name	Description	Mode Note 4-1	Default
<b>Register 11h – Remote Loopback</b>				
11.15:9	Reserved	Reserved	RW	0000_000
11.8	Remote Loopback	1 = Enable remote loopback 0 = Disable remote loopback	RW	0
11.7:1	Reserved	Reserved	RW	1111_010
11.0	Reserved	Reserved	RO	0
<b>Register 12h – LinkMD – Cable Diagnostic</b>				
12.15	Cable Diagnostic Test Enable	Write value: 1 = Enable cable diagnostic test. After test has completed, this bit is self-cleared. 0 = Disable cable diagnostic test. Read value: 1 = Cable diagnostic test is in progress. 0 = Indicates cable diagnostic test (if enabled) has completed and the status information is valid for read.	RW/SC	0
12.14	Reserved	This bit should always be set to '0'.	RW	0

# KSZ9031RNX

**TABLE 4-4: VENDOR-SPECIFIC REGISTER DESCRIPTIONS (CONTINUED)**

Address	Name	Description	Mode Note 4-1	Default
12.13:12	Cable Diagnostic Test Pair	These two bits select the differential pair for testing: 00 = Differential pair A (Pins 2, 3) 01 = Differential pair B (Pins 5, 6) 10 = Differential pair C (Pins 7, 8) 11 = Differential pair D (Pins 10, 11)	RW	00
12.11:10	Reserved	These two bits should always be set to '00'.	RW	00
12.9:8	Cable Diagnostic Status	These two bits represent the test result for the selected differential pair in Bits [13:12] of this register. 00 = Normal cable condition (no fault detected) 01 = Open cable fault detected 10 = Short cable fault detected 11 = Reserved	RO	00
12.7:0	Cable Diagnostic Fault Data	For the open or short cable fault detected in Bits [9:8] of this register, this 8-bit value represents the distance to the cable fault.	RO	0000_0000
<b>Register 13h – Digital PMA/PCS Status</b>				
13.15:3	Reserved	Reserved	RO/LH	0000_0000_0000_0
13.2	1000BASE-T Link Status	1000BASE-T link status 1 = Link status is OK 0 = Link status is not OK	RO	0
13.1	100BASE-TX Link Status	100BASE-TX link status 1 = Link status is OK 0 = Link status is not OK	RO	0
13.0	Reserved	Reserved	RO	0
<b>Register 15h – RXER Counter</b>				
15.15:0	RXER Counter	Receive error counter for symbol error frames	RO/RC	0000_0000_0000_0000
<b>Register 1Bh – Interrupt Control/Status</b>				
1B.15	Jabber Interrupt Enable	1 = Enable jabber interrupt 0 = Disable jabber interrupt	RW	0
1B.14	Receive Error Interrupt Enable	1 = Enable receive error interrupt 0 = Disable receive error interrupt	RW	0
1B.13	Page Received Interrupt Enable	1 = Enable page received interrupt 0 = Disable page received interrupt	RW	0
1B.12	Parallel Detect Fault Interrupt Enable	1 = Enable parallel detect fault interrupt 0 = Disable parallel detect fault interrupt	RW	0
1B.11	Link Partner Acknowledge Interrupt Enable	1 = Enable link partner acknowledge interrupt 0 = Disable link partner acknowledge interrupt	RW	0
1B.10	Link-Down Interrupt Enable	1 = Enable link-down interrupt 0 = Disable link-down interrupt	RW	0

**TABLE 4-4: VENDOR-SPECIFIC REGISTER DESCRIPTIONS (CONTINUED)**

Address	Name	Description	Mode Note 4-1	Default
1B.9	Remote Fault Interrupt Enable	1 = Enable remote fault interrupt 0 = Disable remote fault interrupt	RW	0
1B.8	Link-Up Interrupt Enable	1 = Enable link-up interrupt 0 = Disable link-up interrupt	RW	0
1B.7	Jabber Interrupt	1 = Jabber occurred 0 = Jabber did not occur	RO/RC	0
1B.6	Receive Error Interrupt	1 = Receive error occurred 0 = Receive error did not occur	RO/RC	0
1B.5	Page Receive Interrupt	1 = Page receive occurred 0 = Page receive did not occur	RO/RC	0
1B.4	Parallel Detect Fault Interrupt	1 = Parallel detect fault occurred 0 = Parallel detect fault did not occur	RO/RC	0
1B.3	Link Partner Acknowledge Interrupt	1 = Link partner acknowledge occurred 0 = Link partner acknowledge did not occur	RO/RC	0
1B.2	Link-Down Interrupt	1 = Link-down occurred 0 = Link-down did not occur	RO/RC	0
1B.1	Remote Fault Interrupt	1 = Remote fault occurred 0 = Remote fault did not occur	RO/RC	0
1B.0	Link-Up Interrupt	1 = Link-up occurred 0 = Link-up did not occur	RO/RC	0
<b>Register 1Ch – Auto MDI/MDI-X</b>				
1C.15:8	Reserved	Reserved	RW	0000_0000
1C.7	MDI Set	When Swap-Off (Bit [6] of this register) is asserted (1), 1 = PHY is set to operate as MDI mode 0 = PHY is set to operate as MDI-X mode This bit has no function when Swap-Off is de-asserted (0).	RW	0
1C.6	Swap-Off	1 = Disable Auto MDI/MDI-X function 0 = Enable Auto MDI/MDI-X function	RW	0
1C.5:0	Reserved	Reserved	RW	00_0000
<b>Register 1Fh – PHY Control</b>				
1F.15	Reserved	Reserved	RW	0
1F.14	Interrupt Level	1 = Interrupt pin active high 0 = Interrupt pin active low	RW	0
1F.13:12	Reserved	Reserved	RW	00
1F.11:10	Reserved	Reserved	RO/LH/RC	00
1F.9	Enable Jabber	1 = Enable jabber counter 0 = Disable jabber counter	RW	1
1F.8:7	Reserved	Reserved	RW	00

# KSZ9031RNX

**TABLE 4-4: VENDOR-SPECIFIC REGISTER DESCRIPTIONS (CONTINUED)**

Address	Name	Description	Mode Note 4-1	Default
1F.6	Speed Status 1000BASE-T	1 = Indicate chip final speed status at 1000BASE-T	RO	0
1F.5	Speed Status 100BASE-TX	1 = Indicate chip final speed status at 100BASE-TX	RO	0
1F.4	Speed Status 10BASE-T	1 = Indicate chip final speed status at 10BASE-T	RO	0
1F.3	Duplex Status	Indicate chip duplex status 1 = Full-duplex 0 = Half-duplex	RO	0
1F.2	1000BASE-T Master/Slave Status	Indicate chip master/slave status 1 = 1000BASE-T master mode 0 = 1000BASE-T slave mode	RO	0
1F.1	Reserved	Reserved	RW	0
1F.0	Link Status Check Fail	1 = Fail 0 = Not failing	RO	0

**Note 4-1** RW = Read/Write; RO = Read Only; SC = Self-Cleared; RC = Read-Cleared; LH = Latch High.

## 4.3 MMD Registers

MMD registers provide indirect read/write access to up to 32 MMD device addresses with each device supporting up to 65,536 16-bit registers, as defined in Clause 22 of the IEEE 802.3 Specification. The KSZ9031RNX, however, uses only a small fraction of the available registers. See the [Register Map](#) section for a list of supported MMD device addresses and their associated register addresses.

The following two standard registers serve as the portal registers to access the indirect MMD registers.

- Standard register Dh – MMD Access – Control
- Standard register Eh – MMD Access – Register/Data

**TABLE 4-5: MMD PORTAL REGISTERS**

Address	Name	Description	Mode <a href="#">Note 4-1</a>	Default
<b>Register Dh - MMD Access – Control</b>				
D.15:14	MMD - Operation Mode	For the selected MMD device address (Bits [4:0] of this register), these two bits select one of the following register or data operations and the usage for MMD Access – Register/Data (Reg. Eh). 00 = Register 01 = Data, no post increment 10 = Data, post increment on reads and writes 11 = Data, post increment on writes only	RW	00
D.13:5	Reserved	Reserved	RW	00_0000_000
D.4:0	MMD – Device Address	These five bits set the MMD device address	RW	0_0000
<b>Register Eh - MMD Access – Register/Data</b>				
E.15:0	MMD – Register/Data	For the selected MMD device address (Reg. Dh, Bits [4:0]), When Reg. Dh, Bits [15:14] = 00, this register contains the read/write register address for the MMD device address. Otherwise, this register contains the read/write data value for the MMD device address and its selected register address. See also Register Dh, Bits [15:14] descriptions for post increment reads and writes of this register for data operation.	RW	0000_0000_0000_0000

**Note 4-1** RW = Read/Write.

### Examples:

#### MMD Register Write

Write MMD - Device Address 2h, Register 10h = 0001h to enable link-up detection to trigger PME for WOL.

1. Write Register Dh with 0002h // Set up register address for MMD – Device Address 2h.
2. Write Register Eh with 0010h // Select Register 10h of MMD – Device Address 2h.
3. Write Register Dh with 4002h // Select register data for MMD – Device Address 2h, Register 10h.
4. Write Register Eh with 0001h // Write value 0001h to MMD – Device Address 2h, Register 10h.

#### MMD Register Read

Read MMD - Device Address 2h, Register 11h – 13h for the magic packet's MAC address.

1. Write Register Dh with 0002h // Set up register address for MMD – Device Address 2h.
2. Write Register Eh with 0011h // Select Register 11h of MMD – Device Address 2h.
3. Write Register Dh with 8002h // Select register data for MMD – Device Address 2h, Register 11h.
4. Read Register Eh // Read data in MMD – Device Address 2h, Register 11h.
5. Read Register Eh // Read data in MMD – Device Address 2h, Register 12h.
6. Read Register Eh // Read data in MMD – Device Address 2h, Register 13h.

# KSZ9031RNX

TABLE 4-6: MMD REGISTER DESCRIPTIONS

Address	Name	Description	Mode Note 4-1	Default
<b>MMD Address 0h, Register 3h – AN FLP Burst Transmit – LO</b>				
0.3.15:0	AN FLP Burst Transmit – LO	This register and the following register set the Auto-Negotiation FLP burst transmit timing. The same timing must be set for both registers. 0x4000 = Select 8 ms interval timing (default) 0x1A80 = Select 16 ms interval timing All other values are reserved.	RW	0x4000
<b>MMD Address 0h, Register 4h – AN FLP Burst Transmit – HI</b>				
0.4.15:0	AN FLP Burst Transmit – HI	This register and the previous register set the Auto-Negotiation FLP burst transmit timing. The same timing must be set for both registers. 0x0003 = Select 8 ms interval timing (default) 0x0006 = Select 16 ms interval timing All other values are reserved.	RW	0x0003
<b>MMD Address 1h, Register 5Ah – 1000BASE-T Link-Up Time Control</b>				
1.5A.8:4	Reserved	Reserved	RW	1_0000
1.5A.3:1	1000BASE-T Link-Up Time	When the link partner is another KSZ9031 device, the 1000BASE-T link-up time can be long. These three bits provide an optional setting to reduce the 1000BASE-T link-up time. 100 = Default power-up setting 011 = Optional setting to reduce link-up time when the link partner is a KSZ9031 device. All other settings are reserved and should not be used. The optional setting is safe to use with any link partner. <b>Note:</b> Read/Write access to this register bit is available only when Reg. 0h is set to 0x2100 to disable auto-negotiation and force 100BASE-TX mode.	RW	100
1.5A.0	Reserved	Reserved	RW	0
<b>MMD Address 2h, Register 0h – Common Control</b>				
2.0.15:5	Reserved	Reserved	RW	0000_0000_000
2.0.4	LED Mode Override	Override strap-in for LED_MODE 1 = Single-LED mode 0 = Tri-color dual-LED mode This bit is write-only and always reads back a value of '0'. The updated value is reflected in Bit [3] of this register.	WO	0
2.0.3	LED Mode	LED_MODE Status 1 = Single-LED mode 0 = Tri-color dual-LED mode	RO	Set by LED_MODE strapping pin. See the <a href="#">Strap-In Options - KSZ9031RNX</a> section for details. Can be updated by Bit [4] of this register after reset.
2.0.2	Reserved	Reserved	RW	0

**TABLE 4-6: MMD REGISTER DESCRIPTIONS (CONTINUED)**

Address	Name	Description	Mode Note 4-1	Default
2.0.1	CLK125_EN Status	Override strap-in for CLK125_EN 1 = CLK125_EN strap-in is enabled 0 = CLK125_EN strap-in is disabled	RW	Set by CLK125_EN strapping pin. See the <a href="#">Strap-In Options - KSZ9031RNX</a> section for details.
2.0.0	Reserved	Reserved	RW	0
<b>MMD Address 2h, Register 1h – Strap Status</b>				
2.1.15:8	Reserved	Reserved	RO	0000_0000
2.1.7	LED_MODE Strap-In Status	Strap to 1 = Single-LED mode 0 = Tri-color dual-LED mode	RO	Set by LED_MODE strapping pin. See the <a href="#">Strap-In Options - KSZ9031RNX</a> section for details.
2.1.6	Reserved	Reserved	RO	0
2.1.5	CLK125_EN Strap-In Status	Strap to 1 = CLK125_EN strap-in is enabled 0 = CLK125_EN strap-in is disabled	RO	Set by CLK125_EN strapping pin. See the <a href="#">Strap-In Options - KSZ9031RNX</a> section for details.
2.1.4:3	Reserved	Reserved	RO	00
2.1.2:0	PHYAD[2:0] Strap-In Value	Strap-in value for PHY address Bits [4:3] of PHY address are always set to '00'.	RO	Set by PHYAD[2:0] strapping pin. See the <a href="#">Strap-In Options - KSZ9031RNX</a> section for details.
<b>MMD Address 2h, Register 2h – Operation Mode Strap Override</b>				
2.2.15	RGMII All Capabilities Override	1 = Override strap-in for RGMII to advertise all capabilities	RW	Set by MODE[3:0] strapping pin. See the <a href="#">Strap-In Options - KSZ9031RNX</a> section for details.
2.2.14	RGMII No 1000BT_HD Override	1 = Override strap-in for RGMII to advertise all capabilities except 1000BASE-T half-duplex	RW	
2.2.13	RGMII 1000BT_H/ FD Only Override	1 = Override strap-in for RGMII to advertise 1000BASE-T full- and half-duplex only	RW	
2.2.12	RGMII 1000BT_FD Only Over- ride	1 = Override strap-in for RGMII to advertise 1000BASE-T full-duplex only	RW	
2.2.11	Reserved	Reserved	RW	0
2.2.10	PME_N2 Output Enable	For INT_N/PME_N2 (Pin 38), 1 = Enable PME output 0 = Disable PME output  This bit works in conjunction with MMD Address 2h, Reg. 10h, Bits [15:14] to define the output for Pin 38.	RW	0

# KSZ9031RNX

**TABLE 4-6: MMD REGISTER DESCRIPTIONS (CONTINUED)**

Address	Name	Description	Mode Note 4-1	Default
2.2.9	Reserved	Reserved	RW	0
2.2.8	PME_N1 Output Enable	For LED1/PME_N1 (Pin 17), 1 = Enable PME output 0 = Disable PME output This bit works in conjunction with MMD Address 2h, Reg. 10h, Bits [15:14] to define the output for Pin 17.	RW	0
2.2.7	Chip Power-Down Override	1 = Override strap-in for chip power-down mode	RW	Set by MODE[3:0] strapping pin. See the <a href="#">Strap-In Options - KSZ9031RNX</a> section for details.
2.2.6:5	Reserved	Reserved	RW	00
2.2.4	NAND Tree Override	1 = Override strap-in for NAND Tree mode	RW	Set by MODE[3:0] strapping pin. See the <a href="#">Strap-In Options - KSZ9031RNX</a> section for details.
2.2.3:0	Reserved	Reserved	RW	0000
<b>MMD Address 2h, Register 3h – Operation Mode Strap Status</b>				
2.3.15	RGMII All Capabilities Strap-In Status	1 = Strap to RGMII to advertise all capabilities	RO	Set by MODE[3:0] strapping pin. See the <a href="#">Strap-In Options - KSZ9031RNX</a> section for details.
2.3.14	RGMII No 1000BT_HD Strap-In Status	1 = Strap to RGMII to advertise all capabilities except 1000BASE-T half-duplex	RO	
2.3.13	RGMII Only 1000BT_H/ FD Strap-In Status	1 = Strap to RGMII to advertise 1000BASE-T full- and half-duplex only	RO	
2.3.12	RGMII Only 1000BT_FD Strap-In Status	1 = Strap to RGMII to advertise 1000BASE-T full-duplex only	RO	
2.3.11:8	Reserved	Reserved	RO	0000
2.3.7	Chip Power-Down Strap-In Status	1 = Strap to chip power-down mode	RO	Set by MODE[3:0] strapping pin. See the <a href="#">Strap-In Options - KSZ9031RNX</a> section for details.
2.3.6:5	Reserved	Reserved	RO	00

**TABLE 4-6: MMD REGISTER DESCRIPTIONS (CONTINUED)**

Address	Name	Description	Mode Note 4-1	Default
2.3.4	NAND Tree Strap-In Status	1 = Strap to NAND Tree mode	RO	Set by MODE[3:0] strapping pin. See the <a href="#">Strap-In Options - KSZ9031RNX</a> section for details.
2.3.3:0	Reserved	Reserved	RO	0000
<b>MMD Address 2h, Register 4h – RGMII Control Signal Pad Skew</b>				
2.4.15:8	Reserved	Reserved	RW	0000_0000
2.4.7:4	RX_DV Pad Skew	RGMII RX_CTL output pad skew control (0.06 ns/step)	RW	0111
2.4.3:0	TX_EN Pad Skew	RGMII TX_CTL input pad skew control (0.06 ns/step)	RW	0111
<b>MMD Address 2h, Register 5h – RGMII RX Data Pad Skew</b>				
2.5.15:12	RXD3 Pad Skew	RGMII RXD3 output pad skew control (0.06 ns/step)	RW	0111
2.5.11:8	RXD2 Pad Skew	RGMII RXD2 output pad skew control (0.06 ns/step)	RW	0111
2.5.7:4	RXD1 Pad Skew	RGMII RXD1 output pad skew control (0.06 ns/step)	RW	0111
2.5.3:0	RXD0 Pad Skew	RGMII RXD0 output pad skew control (0.06 ns/step)	RW	0111
<b>MMD Address 2h, Register 6h – RGMII TX Data Pad Skew</b>				
2.6.15:12	TXD3 Pad Skew	RGMII TXD3 input pad skew control (0.06 ns/step)	RW	0111
2.6.11:8	TXD2 Pad Skew	RGMII TXD2 input pad skew control (0.06 ns/step)	RW	0111
2.6.7:4	TXD1 Pad Skew	RGMII TXD1 input pad skew control (0.06 ns/step)	RW	0111
2.6.3:0	TXD0 Pad Skew	RGMII TXD0 input pad skew control (0.06 ns/step)	RW	0111
<b>MMD Address 2h, Register 8h – RGMII Clock Pad Skew</b>				
2.8.15:10	Reserved	Reserved	RW	0000_00
2.8.9:5	GTX_CLK Pad Skew	RGMII GTX_CLK input pad skew control (0.06 ns/step)	RW	01_111
2.8.4:0	RX_CLK Pad Skew	RGMII RX_CLK output pad skew control (0.06 ns/step)	RW	0_1111

# KSZ9031RNX

**TABLE 4-6: MMD REGISTER DESCRIPTIONS (CONTINUED)**

Address	Name	Description	Mode Note 4-1	Default
<b>MMD Address 2h, Register 10h – Wake-On-LAN – Control</b>				
2.10.15:14	PME Output Select	These two bits work in conjunction with MMD Address 2h, Reg. 2h, Bits [8] and [10] for PME_N1 and PME_N2 enable, to define the output for Pins 17 and 38, respectively. LED1/PME_N1 (Pin 17) 00 = PME_N1 output only 01 = LED1 output only 10 = LED1 and PME_N1 output 11 = Reserved INT_N/PME_N2 (Pin 38) 00 = PME_N2 output only 01 = INT_N output only 10 = INT_N and PME_N2 output 11 = Reserved	RW	00
2.10.13:7	Reserved	Reserved	RW	00_0000_0
2.10.6	MagicPacket Detect Enable	1 = Enable magic-packet detection 0 = Disable magic-packet detection	RW	0
2.10.5	Custom-Packet Type 3 Detect Enable	1 = Enable custom-packet, Type 3 detection 0 = Disable custom-packet, Type 3 detection	RW	0
2.10.4	Custom-Packet Type 2 Detect Enable	1 = Enable custom-packet, Type 2 detection 0 = Disable custom-packet, Type 2 detection	RW	0
2.10.3	Custom-Packet Type 1 Detect Enable	1 = Enable custom-packet, Type 1 detection 0 = Disable custom-packet, Type 1 detection	RW	0
2.10.2	Custom-Packet Type 0 Detect Enable	1 = Enable custom-packet, Type 0 detection 0 = Disable custom-packet, Type 0 detection	RW	0
2.10.1	Link-Down Detect Enable	1 = Enable link-down detection 0 = Disable link-down detection	RW	0
2.10.0	Link-Up Detect Enable	1 = Enable link-up detection 0 = Disable link-up detection	RW	0
<b>MMD Address 2h, Register 11h – Wake-On-LAN – Magic Packet, MAC-DA-0</b>				
2.11.15:0	MagicPacket MAC-DA-0	This register stores the lower two bytes of the destination MAC address for the magic packet. Bit [15:8] = Byte 2 (MAC Address [15:8]) Bit [7:0] = Byte 1 (MAC Address [7:0]) The upper four bytes of the destination MAC address are stored in the following two registers.	RW	0000_0000_0000_0000

**TABLE 4-6: MMD REGISTER DESCRIPTIONS (CONTINUED)**

Address	Name	Description	Mode Note 4-1	Default
<b>MMD Address 2h, Register 12h – Wake-On-LAN – Magic Packet, MAC-DA-1</b>				
2.12.15:0	MagicPacket MAC-DA-1	This register stores the middle two bytes of the destination MAC address for the magic packet. Bit [15:8] = Byte 4 (MAC Address [31:24]) Bit [7:0] = Byte 3 (MAC Address [23:16]) The lower two bytes and upper two bytes of the destination MAC address are stored in the previous and following registers, respectively.	RW	0000_0000_0000_0000
<b>MMD Address 2h, Register 13h – Wake-On-LAN – Magic Packet, MAC-DA-2</b>				
2.13.15:0	MagicPacket MAC-DA-2	This register stores the upper two bytes of the destination MAC address for the magic packet. Bit [15:8] = Byte 6 (MAC Address [47:40]) Bit [7:0] = Byte 5 (MAC Address [39:32]) The lower four bytes of the destination MAC address are stored in the previous two registers.	RW	0000_0000_0000_0000
<b>MMD Address 2h, Register 14h – Wake-On-LAN – Customized Packet, Type 0, Expected CRC 0</b> <b>MMD Address 2h, Register 16h – Wake-On-LAN – Customized Packet, Type 1, Expected CRC 0</b> <b>MMD Address 2h, Register 18h – Wake-On-LAN – Customized Packet, Type 2, Expected CRC 0</b> <b>MMD Address 2h, Register 1Ah – Wake-On-LAN – Customized Packet, Type 3, Expected CRC 0</b>				
2.14.15:0 2.16.15:0 2.18.15:0 2.1A.15:0	Custom Packet Type X CRC 0	This register stores the upper two bytes for the expected CRC. Bit [15:8] = Byte 2 (CRC [15:8]) Bit [7:0] = Byte 1 (CRC [7:0]) The lower two bytes for the expected CRC are stored in the following register.	RW	0000_0000_0000_0000
<b>MMD Address 2h, Register 15h – Wake-On-LAN – Customized Packet, Type 0, Expected CRC 1</b> <b>MMD Address 2h, Register 17h – Wake-On-LAN – Customized Packet, Type 1, Expected CRC 1</b> <b>MMD Address 2h, Register 19h – Wake-On-LAN – Customized Packet, Type 2, Expected CRC 1</b> <b>MMD Address 2h, Register 1Bh – Wake-On-LAN – Customized Packet, Type 3, Expected CRC 1</b>				
2.15.15:0 2.17.15:0 2.19.15:0 2.1B.15:0	Custom Packet Type X CRC 1	This register stores the lower two bytes for the expected CRC. Bit [15:8] = Byte 4 (CRC [31:24]) Bit [7:0] = Byte 3 (CRC [23:16]) The upper two bytes for the expected CRC are stored in the previous register.	RW	0000_0000_0000_0000
<b>MMD Address 2h, Register 1Ch – Wake-On-LAN – Customized Packet, Type 0, Mask 0</b> <b>MMD Address 2h, Register 20h – Wake-On-LAN – Customized Packet, Type 1, Mask 0</b> <b>MMD Address 2h, Register 24h – Wake-On-LAN – Customized Packet, Type 2, Mask 0</b> <b>MMD Address 2h, Register 28h – Wake-On-LAN – Customized Packet, Type 3, Mask 0</b>				
2.1C.15:0 2.20.15:0 2.24.15:0 2.28.15:0	Custom Packet Type X Mask 0	This register selects the bytes in the first 16 bytes of the packet (bytes 1 through 16) that will be used for CRC calculation. For each bit in this register, 1 = Byte is selected for CRC calculation 0 = Byte is not selected for CRC calculation The register-bit to packet-byte mapping is as follows: Bit [15]: Byte 16 ..... Bit [2]: Byte 2 Bit [0]: Byte 1	RW	0000_0000_0000_0000

# KSZ9031RNX

**TABLE 4-6: MMD REGISTER DESCRIPTIONS (CONTINUED)**

Address	Name	Description	Mode Note 4-1	Default
<b>MMD Address 2h, Register 1Dh – Wake-On-LAN – Customized Packet, Type 0, Mask 1</b> <b>MMD Address 2h, Register 21h – Wake-On-LAN – Customized Packet, Type 1, Mask 1</b> <b>MMD Address 2h, Register 25h – Wake-On-LAN – Customized Packet, Type 2, Mask 1</b> <b>MMD Address 2h, Register 29h – Wake-On-LAN – Customized Packet, Type 3, Mask 1</b>				
2.1D.15:0 2.21.15:0 2.25.15:0 2.29.15:0	Custom Packet Type X Mask 1	This register selects the bytes in the second 16 bytes of the packet (bytes 17 thru 32) that will be used for CRC calculation. For each bit in this register, 1 = Byte is selected for CRC calculation 0 = Byte is not selected for CRC calculation The register-bit to packet-byte mapping is as follows: Bit [15]: Byte 32 ..... Bit [2]: Byte 18 Bit [0]: Byte 17	RW	0000_0000_0000_0000
<b>MMD Address 2h, Register 1Eh – Wake-On-LAN – Customized Packet, Type 0, Mask 2</b> <b>MMD Address 2h, Register 22h – Wake-On-LAN – Customized Packet, Type 1, Mask 2</b> <b>MMD Address 2h, Register 26h – Wake-On-LAN – Customized Packet, Type 2, Mask 2</b> <b>MMD Address 2h, Register 2Ah – Wake-On-LAN – Customized Packet, Type 3, Mask 2</b>				
2.1E.15:0 2.22.15:0 2.26.15:0 2.2A.15:0	Custom Packet Type X Mask 2	This register selects the bytes in the third 16 bytes of the packet (bytes 33 through 48) that will be used for CRC calculation. For each bit in this register, 1 = Byte is selected for CRC calculation 0 = Byte is not selected for CRC calculation The register-bit to packet-byte mapping is as follows: Bit [15]: Byte 48 ..... Bit [2]: Byte 34 Bit [0]: Byte 33	RW	0000_0000_0000_0000
<b>MMD Address 2h, Register 1Fh – Wake-On-LAN – Customized Packet, Type 0, Mask 3</b> <b>MMD Address 2h, Register 23h – Wake-On-LAN – Customized Packet, Type 1, Mask 3</b> <b>MMD Address 2h, Register 27h – Wake-On-LAN – Customized Packet, Type 2, Mask 3</b> <b>MMD Address 2h, Register 2Bh – Wake-On-LAN – Customized Packet, Type 3, Mask 3</b>				
2.1F.15:0 2.23.15:0 2.27.15:0 2.2B.15:0	Custom Packet Type X Mask 3	This register selects the bytes in the fourth 16 bytes of the packet (bytes 49 through 64) that will be used for CRC calculation. For each bit in this register, 1 = Byte is selected for CRC calculation 0 = Byte is not selected for CRC calculation The register-bit to packet-byte mapping is as follows: Bit [15]: Byte 64 ..... Bit [2]: Byte 50 Bit [0]: Byte 49	RW	0000_0000_0000_0000
<b>MMD Address 1Ch, Register 4h – Analog Control 4</b>				
1C.4.15:11	Reserved	Reserved	RW	0000_0
1C.4.10	10BASE-Te Mode	1 = 10BASE-Te (1.75V TX amplitude) 0 = Standard 10BASE-T (2.5V TX amplitude)	RW	0
1C.4.9:0	Reserved	Reserved	RW	00_1111_1111

**TABLE 4-6: MMD REGISTER DESCRIPTIONS (CONTINUED)**

Address	Name	Description	Mode <a href="#">Note 4-1</a>	Default
<b>MMD Address 1Ch, Register 23h – EDPD Control</b>				
1C.23.15:1	Reserved	Reserved	RW	0000_0000_0000_000
1C.23.0	EDPD Mode Enable	Energy-detect power-down mode 1 = Enable 0 = Disable	RW	0

**Note 4-1** RW = Read/Write; RO = Read Only; WO = Write Only; LH = Latch High.

# KSZ9031RNX

## 5.0 OPERATIONAL CHARACTERISTICS

### 5.1 Absolute Maximum Ratings\*

Supply Voltage ( $V_{IN}$ )	
(DVDDL, AVDDL, AVDDL_PLL) .....	-0.5V to +1.8V
(AVDDH).....	-0.5V to +5.0V
(DVDDH).....	-0.5V to +5.0V
Input Voltage (all inputs).....	-0.5V to +5.0V
Output Voltage (all outputs).....	-0.5V to +5.0V
Lead Temperature (soldering, 10s) .....	+260°C
Storage Temperature ( $T_S$ ).....	-55°C to +150°C

\*Exceeding the absolute maximum rating may damage the device. Stresses greater than the absolute maximum rating may cause permanent damage to the device. Operation of the device at these or any other conditions above those specified in the operating sections of this specification is not implied. Maximum conditions for extended periods may affect reliability.

### 5.2 Operating Ratings\*\*

Supply Voltage	
(DVDDL, AVDDL, AVDDL_PLL) .....	+1.140V to +1.380V
(AVDDH @ 3.3V).....	+3.135V to +3.465V
(AVDDH @ 2.5V; Commercial temp. only).....	+2.375V to +2.625V
(DVDDH @ 3.3V).....	+3.135V to +3.465V
(DVDDH @ 2.5V).....	+2.375V to +2.625V
(DVDDH @ 1.8V).....	+1.710V to +1.890V
Ambient Temperature	
( $T_A$ Commercial: KSZ9031RNXC) .....	0°C to +70°C
( $T_A$ Industrial: KSZ9031RNXI).....	-40°C to +85°C
( $T_A$ Automotive: KSZ9031RNXUA/UB) .....	-40°C to +85°C
( $T_A$ Automotive: KSZ9031RNXVA/VB).....	-40°C to +105°C
Maximum Junction Temperature ( $T_J$ max.) .....	+125°C
Thermal Resistance ( $\Theta_{JA}$ ).....	+36.34°C/W
Thermal Resistance ( $\Theta_{JC}$ ).....	+9.47°C/W

\*\*The device is not guaranteed to function outside its operating ratings.

**Note:** Do not drive input signals without power supplied to the device.

## 6.0 ELECTRICAL CHARACTERISTICS

T<sub>A</sub> = 25°C. Specification is for packaged product only.

**TABLE 6-1: SUPPLY CURRENT - CORE/DIGITAL I/O**

Parameters	Symbol	Min.	Typ.	Max.	Units	Note
1.2V Total of: DVDDL (digital core) + AVDDL (analog core) + AVDDL_PLL (PLL)	I <sub>CORE</sub>	—	210	—	mA	1000BASE-T link-up (no traffic)
		—	221	—		1000BASE-T full-duplex @ 100% utilization
		—	63.6	—		100BASE-TX link-up (no traffic)
		—	63.8	—		100BASE-TX full-duplex @ 100% utilization
		—	7.1	—		10BASE-T link-up (no traffic)
		—	7.7	—		10BASE-T full-duplex @ 100% utilization
		—	1.0	—		Software power-down mode (Reg. 0.11 = 1)
		—	0.7	—		Chip power-down mode (strap-in pins MODE[3:0] = 0111)
1.8V for Digital I/O (RGMII operating @ 1.8V)	I <sub>DVDDH_1.8</sub>	—	11.2	—	mA	1000BASE-T link-up (no traffic)
		—	23.6	—		1000BASE-T full-duplex @ 100% utilization
		—	8.4	—		100BASE-TX link-up (no traffic)
		—	9.8	—		100BASE-TX full-duplex @ 100% utilization
		—	3.6	—		10BASE-T link-up (no traffic)
		—	5.6	—		10BASE-T full-duplex @ 100% utilization
		—	5.5	—		Software power-down mode (Reg. 0.11 = 1)
		—	0.3	—		Chip power-down mode (strap-in pins MODE[3:0] = 0111)
2.5V for Digital I/O (RGMII operating @ 2.5V)	I <sub>DVDDH_2.5</sub>	—	14.7	—	mA	1000BASE-T link-up (no traffic)
		—	31.5	—		1000BASE-T full-duplex @ 100% utilization
		—	10.5	—		100BASE-TX link-up (no traffic)
		—	13.0	—		100BASE-TX full-duplex @ 100% utilization
		—	6.3	—		10BASE-T link-up (no traffic)
		—	9.0	—		10BASE-T full-duplex @ 100% utilization
		—	6.7	—		Software power-down mode (Reg. 0.11 = 1)
		—	0.7	—		Chip power-down mode (strap-in pins MODE[3:0] = 0111)

# KSZ9031RNX

**TABLE 6-1: SUPPLY CURRENT - CORE/DIGITAL I/O (CONTINUED)**

Parameters	Symbol	Min.	Typ.	Max.	Units	Note
3.3V for Digital I/O (RGMII operating @ 3.3V)	I <sub>DVDDH_3.3</sub>	—	19.5	—	mA	1000BASE-T link-up (no traffic)
		—	41.5	—		1000BASE-T full-duplex @ 100% utilization
		—	13.9	—		100BASE-TX link-up (no traffic)
		—	17.2	—		100BASE-TX full-duplex @ 100% utilization
		—	11.5	—		10BASE-T link-up (no traffic)
		—	13.7	—		10BASE-T full-duplex @ 100% utilization
		—	9.3	—		Software power-down mode (Reg. 0.11 = 1)
		—	2.2	—		Chip power-down mode (strap-in pins MODE[3:0] = 0111)

**TABLE 6-2: SUPPLY CURRENT - TRANSCEIVER (Note 6-1)**

Parameters	Symbol	Min.	Typ.	Max.	Units	Note
2.5V for Transceiver (Recommended for commercial temperature range operation only)	I <sub>AVDDH_2.5</sub>	—	58.8	—	mA	1000BASE-T link-up (no traffic)
		—	57.9	—		1000BASE-T full-duplex @ 100% utilization
		—	24.9	—		100BASE-TX link-up (no traffic)
		—	24.9	—		100BASE-TX full-duplex @ 100% utilization
		—	11.5	—		10BASE-T link-up (no traffic)
		—	25.3	—		10BASE-T full-duplex @ 100% utilization
		—	3.1	—		Software power-down mode (Reg. 0.11 = 1)
		—	0.02	—		Chip power-down mode (strap-in pins MODE[3:0] = 0111)
3.3V for Transceiver Parameter	I <sub>AVDDH_3.3</sub>	—	67.4	—	mA	1000BASE-T link-up (no traffic)
		—	66.3	—		1000BASE-T full-duplex @ 100% utilization
		—	28.7	—		100BASE-TX link-up (no traffic)
		—	28.6	—		100BASE-TX full-duplex @ 100% utilization
		—	15.9	—		10BASE-T link-up (no traffic)
		—	28.6	—		10BASE-T full-duplex @ 100% utilization
		—	4.2	—		Software power-down mode (Reg. 0.11 = 1)
		—	0.02	—		Chip power-down mode (strap-in pins MODE[3:0] = 0111)

**Note 6-1** Equivalent to current draw through external transformer center taps for PHY transceivers with current-mode transmit drivers.

**TABLE 6-3: CMOS INPUTS**

Parameters	Symbol	Min.	Typ.	Max.	Units	Note
Input High Voltage	$V_{IH}$	2.0	—	—	V	DVDDH (digital I/O) = 3.3V
		1.5	—	—		DVDDH (digital I/O) = 2.5V
		1.1	—	—		DVDDH (digital I/O) = 1.8V
Input Low Voltage	$V_{IL}$	—	—	1.3	V	DVDDH (digital I/O) = 3.3V
		—	—	1.0		DVDDH (digital I/O) = 2.5V
		—	—	0.7		DVDDH (digital I/O) = 1.8V
Input High Leakage Current	$I_{IHL}$	-2.0	—	2.0	$\mu\text{A}$	DVDDH = 3.3V and $V_{IH}$ = 3.3V All digital input pins
Input Low Leakage Current	$I_{ILL}$	-2.0	—	2.0	$\mu\text{A}$	DVDDH = 3.3V and $V_{IL}$ = 0.0V All digital input pins, except MDC, MDIO, RESET_N.
		-120	—	-40		DVDDH = 3.3V and $V_{IL}$ = 0.0V MDC, MDIO, RESET_N pins with internal pull-ups

**TABLE 6-4: CMOS OUTPUTS**

Parameter	Symbol	Min.	Typ.	Max.	Units	Note
Output High Voltage	$V_{OH}$	2.7	—	—	V	DVDDH (digital I/O) = 3.3V, $I_{OH}$ (min) = 10 mA All digital output pins
		2.0	—	—		DVDDH (digital I/O) = 2.5V, $I_{OH}$ (min) = 10 mA All digital output pins
		1.5	—	—		DVDDH (digital I/O) = 1.8V, $I_{OH}$ (min) = 13 mA All digital output pins, except LED1, LED2
Output Low Voltage	$V_{OL}$	—	—	0.3	V	DVDDH (digital I/O) = 3.3V, $I_{OL}$ (min) = 10 mA All digital output pins
		—	—	0.3		DVDDH (digital I/O) = 2.5V, $I_{OL}$ (min) = 10 mA All digital output pins
		—	—	0.3		DVDDH (digital I/O) = 1.8V, $I_{OL}$ (min) = 13 mA All digital output pins, except LED1, LED2
Output Tri-State Leakage	$ I_{oz} $	—	—	10	$\mu\text{A}$	—

**TABLE 6-5: LED OUTPUTS**

Parameters	Symbol	Min.	Typ.	Max.	Units	Note
Output Drive Current	$I_{LED}$	10	—	—	mA	DVDDH (digital I/O) = 3.3V or 2.5V, and $V_{OL}$ at 0.3V Each LED pin (LED1, LED2)

# KSZ9031RNX

**TABLE 6-6: PULL-UP PINS (Note 6-2)**

Parameters	Symbol	Min.	Typ.	Max.	Units	Note
Internal Pull-Up Resistance (MDC, MDIO, RESET_N pins)	pu	13	22	31	kΩ	DVDDH (digital I/O) = 3.3V
		16	28	39		DVDDH (digital I/O) = 2.5V
		26	44	62		DVDDH (digital I/O) = 1.8V

**Note 6-2** Measured with pin input voltage level at one-half DVDDH.

**TABLE 6-7: 100BASE-TX TRANSMIT (Note 6-3)**

Parameters	Symbol	Min.	Typ.	Max.	Units	Note
Peak Differential Output Voltage	$V_O$	0.95	—	1.05	V	100Ω termination across differential output
Output Voltage Imbalance	$V_{IMB}$	—	—	2	%	100Ω termination across differential output
Rise/Fall Time	$t_r, t_f$	3	—	5	ns	—
Rise/Fall Time Imbalance	—	0	—	0.5	ns	—
Duty Cycle Distortion	—	—	—	±0.25	ns	—
Overshoot	—	—	—	5	%	—
Output Jitter	—	—	0.7	—	ns	Peak-to-peak

**Note 6-3** Measured differentially after 1:1 transformer.

**TABLE 6-8: 10BASE-T TRANSMIT (Note 6-4)**

Parameters	Symbol	Min.	Typ.	Max.	Units	Note
Peak Differential Output Voltage	$V_P$	2.2	—	2.8	V	100Ω termination across differential output
Jitter Added	—	—	—	3.5	ns	Peak-to-peak
Harmonic Rejection	—	—	-31	—	dB	Transmit all-one signal sequence

**Note 6-4** Measured differentially after 1:1 transformer.

**TABLE 6-9: 10BASE-T RECEIVE**

Parameters	Symbol	Min.	Typ.	Max.	Units	Note
Squelch Threshold	$V_{SQ}$	300	400	—	mV	5 MHz square wave

**TABLE 6-10: TRANSMITTER - DRIVE SETTING**

Parameters	Symbol	Min.	Typ.	Max.	Units	Note
Reference Voltage of $I_{SET}$	$V_{SET}$	—	1.2	—	V	$R(I_{SET}) = 12.1 \text{ k}\Omega$

**TABLE 6-11: LDO CONTROLLER - DRIVE RANGE**

Parameters	Symbol	Min.	Typ.	Max.	Units	Note
Output drive range for LDO_O (Pin 43) to gate input of P-channel MOSFET	$V_{LDO\_O}$	0.85	—	2.8	V	AVDDH = 3.3V for MOSFET source voltage
		0.85	—	2.0		AVDDH = 2.5V for MOSFET source voltage (recommended for commercial temperature range operation only)

## 7.0 TIMING DIAGRAMS

### 7.1 RGMII Timing

As the default, after power-up or reset, the KSZ9031RNX RGMII timing conforms to the timing requirements in the RGMII Version 2.0 Specification for internal PHY chip delay.

For the transmit path (MAC to KSZ9031RNX), the KSZ9031RNX does not add any delay locally at its GTX\_CLK, TX\_EN and TXD[3:0] input pins, and expects the GTX\_CLK delay to be provided on-chip by the MAC. If MAC does not provide any delay or insufficient delay for the GTX\_CLK, the KSZ9031RNX has pad skew registers that can provide up to 1.38 ns on-chip delay.

For the receive path (KSZ9031RNX to MAC), the KSZ9031RNX adds 1.2 ns typical delay to the RX\_CLK output pin with respect to RX\_DV and RXD[3:0] output pins. If necessary, the KSZ9031RNX has pad skew registers that can adjust the RX\_CLK on-chip delay up to 2.58 ns from the 1.2 ns default delay.

It is common to implement RGMII PHY-to-MAC designs that either PHY, MAC, or both PHY and MAC are not fully RGMII v2.0 compliant with on-chip clock delay. These combinations of mixed RGMII v1.3/v2.0 designs and plus sometimes non-matching RGMII PCB trace routings require a review of the entire RGMII system timings (PHY on-chip, PCB trace delay, MAC on-chip) to compute the aggregate clock delay and determine if the clock delay timing is met. If timing adjustment is needed, pad skew registers are provided by the KSZ9031RNX. Refer to RGMII Pad Skew Registers section.

The following [Figure 7-1](#), [Figure 7-2](#), and [Table 7-1](#) from the RGMII v2.0 Specification are provided as references to understanding RGMII v1.3 external delay and RGMII v2.0 on-chip delay timings.

**FIGURE 7-1: RGMII V2.0 SPEC (MULTIPLEXING AND TIMING DIAGRAM – ORIGINAL RGMII (V1.3) WITH EXTERNAL DELAY)**

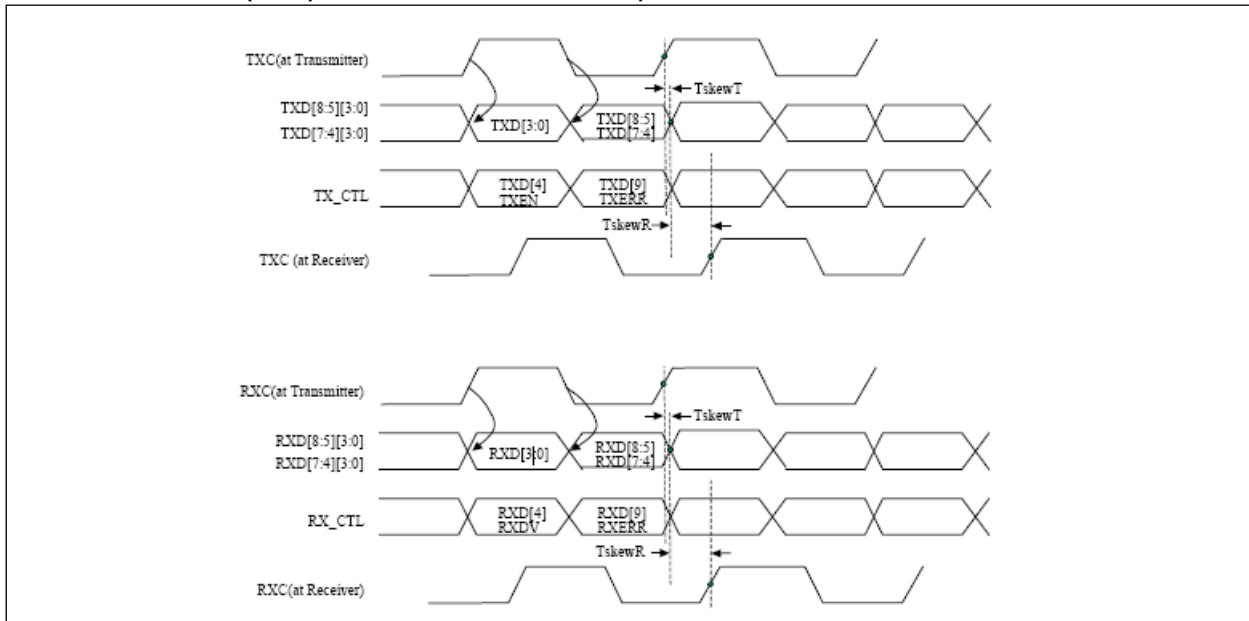

# KSZ9031RNX

**FIGURE 7-2: RGMII V2.0 SPEC (MULTIPLEXING AND TIMING DIAGRAM – RGMII-ID (V2.0) WITH INTERNAL CHIP DELAY)**

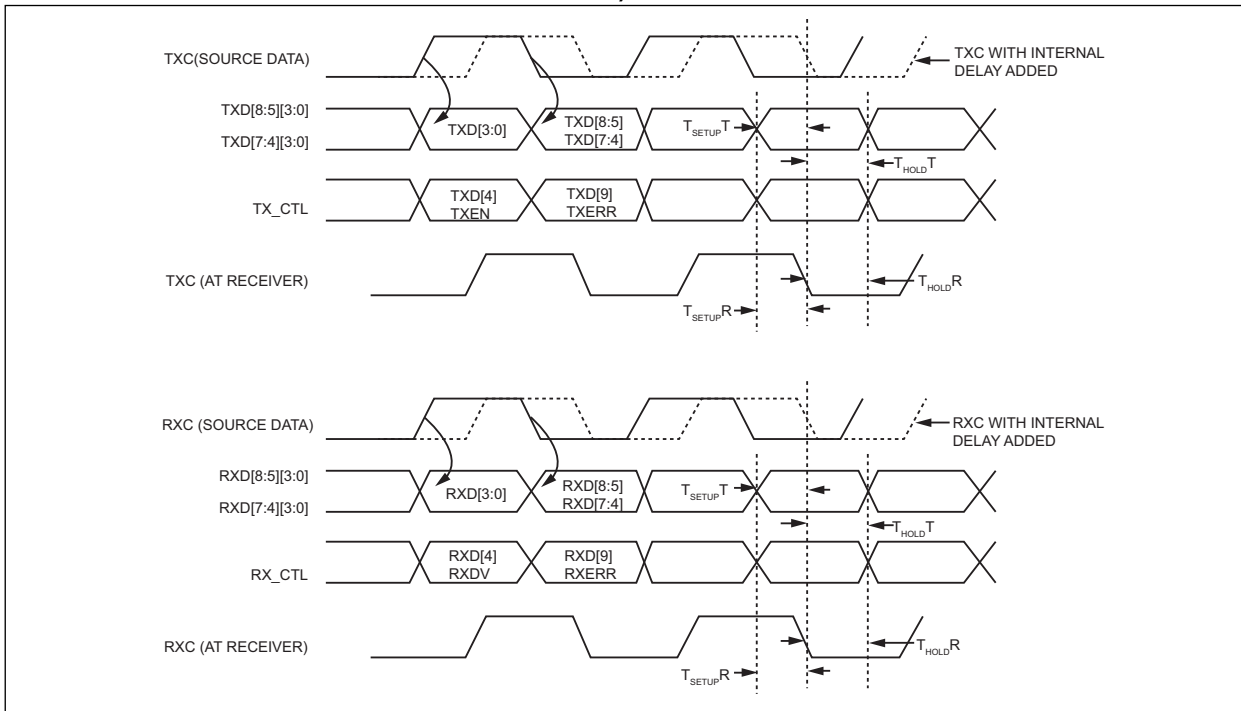

The following notes provide clarification for [Figure 7-2](#).

**TXC (SOURCE DATA)**, solid line, is the MAC GTX\_CLK clock output timing per RGMII v1.3 Specification (PCB delay line required or PHY internal delay required)

**TXC (SOURCE DATA) WITH INTERNAL DELAY ADDED**, dotted line, is the MAC GTX\_CLK clock output timing per RGMII v2.0 Specification (no PCB delay required and no PHY internal delay required)

**RXC (SOURCE DATA)**, solid line, is the PHY RX\_CLK clock output timing per RGMII v1.3 Specification (PCB delay line required or MAC internal delay required)

**RXC (SOURCE DATA) WITH INTERNAL DELAY ADDED**, dotted line, is the PHY RX\_CLK clock output timing per RGMII v2.0 Specification (no PCB delay required and no MAC internal delay required)

**TABLE 7-1: RGMII V2.0 SPECIFICATION**

Parameter	Description	Min.	Typ.	Max.	Units
$T_{skew}^T$	Data-to-clock output skew (at transmitter) per RGMII v1.3 (external delay)	-500	—	500	ps
$T_{skew}^R$	Data-to-clock input skew (at receiver) per RGMII v1.3 (external delay)	1.0	—	2.6	ns
$T_{setup}^T$	Data-to-clock output setup (at transmitter – integrated delay)	1.2	2.0	—	
$T_{hold}^T$	Clock-to-data output hold (at transmitter – integrated delay)	1.2	2.0	—	
$T_{setup}^R$	Data-to-clock input setup (at receiver – integrated delay)	1.0	2.0	—	
$T_{hold}^R$	Clock-to-data input hold (at receiver – integrated delay)	1.0	2.0	—	
$t_{cyc}$ (1000BASE-T)	Clock cycle duration for 1000BASE-T	7.2	8.0	8.8	
$t_{cyc}$ (100BASE-TX)	Clock cycle duration for 100BASE-TX	36	40	44	
$t_{cyc}$ (10BASE-T)	Clock cycle duration for 10BASE-T	360	400	440	

The RGMII Version 2.0 Specification defines the RGMII data-to-clock skews only for 1000 Mbps operation, which uses both clock edges for sampling the data and control signals at the 125 MHz clock frequency (8 ns period). For 10/100 Mbps operations, the data signals are sampled on the rising clock edge and the control signals are sampled on both clock edges. With slower clock frequencies, 2.5 MHz (400 ns period) for 10 Mbps and 25 MHz (40 ns period) for 100 Mbps, the RGMII data-to-clock skews for 10/100 Mbps operations will have greater timing margins than for 1000 Mbps operation, and therefore can be relaxed from 2.6 ns (maximum) for 1000 Mbps to 160 ns (maximum) for 10 Mbps and 16 ns (maximum) for 100 Mbps.

# KSZ9031RNX

**FIGURE 7-3: AUTO-NEGOTIATION FAST LINK PULSE (FLP) TIMING**

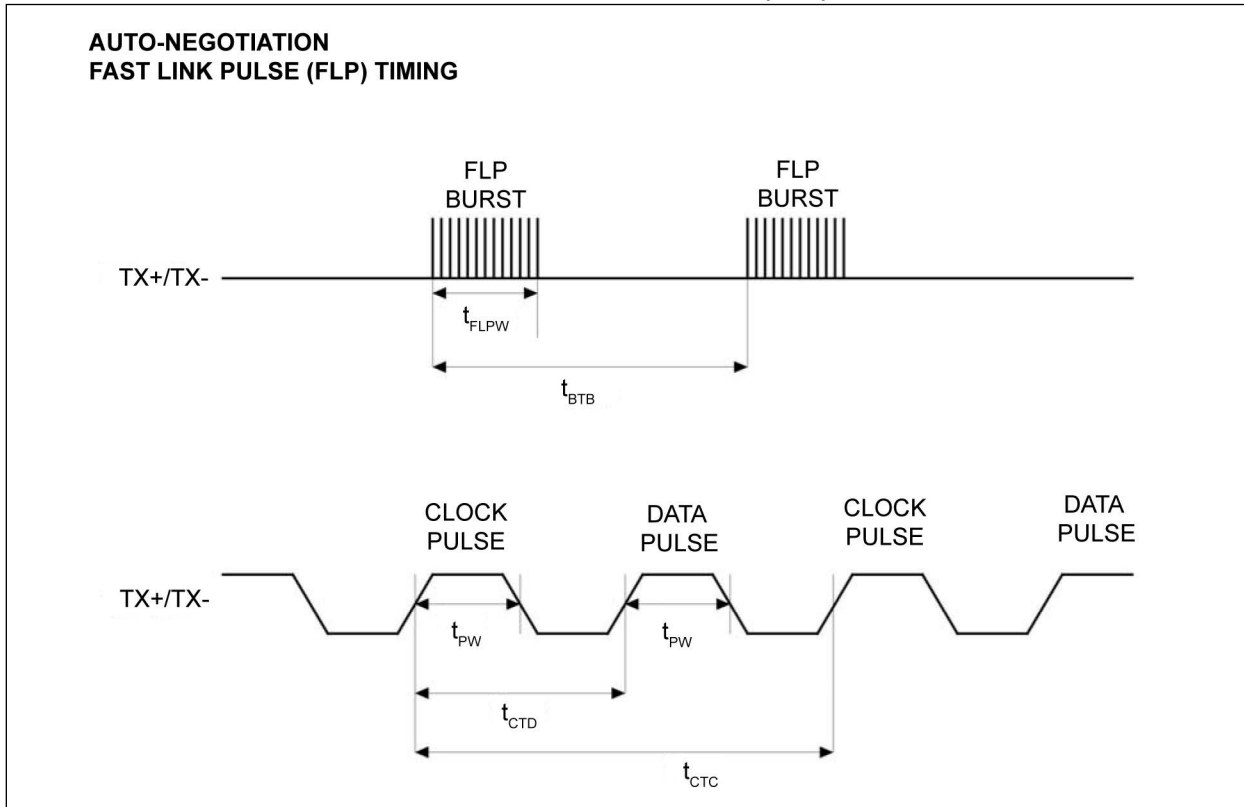

**TABLE 7-2: AUTO-NEGOTIATION FAST LINK PULSE (FLP) TIMING PARAMETERS**

Timing Parameter	Description	Min.	Typ.	Max.	Units
$t_{BTB}$	FLP burst to FLP burst	8	16	24	ms
$t_{FLPW}$	FLP burst width	—	2	—	
$t_{PW}$	Clock/Data pulse width	—	100	—	$\mu$ s
$t_{CTD}$	Clock pulse to data pulse	55.5	64	69.5	
$t_{CTC}$	Clock pulse to clock pulse	111	128	139	
—	Number of clock/data pulses per FLP burst	17	—	33	—

The KSZ9031RNX Fast Link Pulse (FLP) burst-to-burst transmit timing for Auto-Negotiation defaults to 8 ms. IEEE 802.3 Standard specifies this timing to be 16 ms  $\pm$  8 ms. Some PHY link partners need to receive the FLP with 16 ms centered timing; otherwise, there can be intermittent link failures and long link-up times.

After KSZ9031RNX power-up/reset, program the following register sequence to set the FLP timing to 16 ms:

1. Write Register Dh = 0x0000 // Set up register address for MMD – Device Address 0h
2. Write Register Eh = 0x0004 // Select Register 4h of MMD – Device Address 0h
3. Write Register Dh = 0x4000 // Select register data for MMD – Device Address 0h, Register 4h
4. Write Register Eh = 0x0006 // Write value 0x0006 to MMD – Device Address 0h, Register 4h
5. Write Register Dh = 0x0000 // Set up register address for MMD – Device Address 0h
6. Write Register Eh = 0x0003 // Select Register 3h of MMD – Device Address 0h
7. Write Register Dh = 0x4000 // Select register data for MMD – Device Address 0h, Register 3h
8. Write Register Eh = 0x1A80 // Write value 0x1A80 to MMD – Device Address 0h, Register 3h
9. Write Register 0h, Bit [9] = 1 // Restart Auto-Negotiation

The above setting for 16 ms FLP transmit timing is compatible with all PHY link partners.

**FIGURE 7-4: MDC/MDIO TIMING**

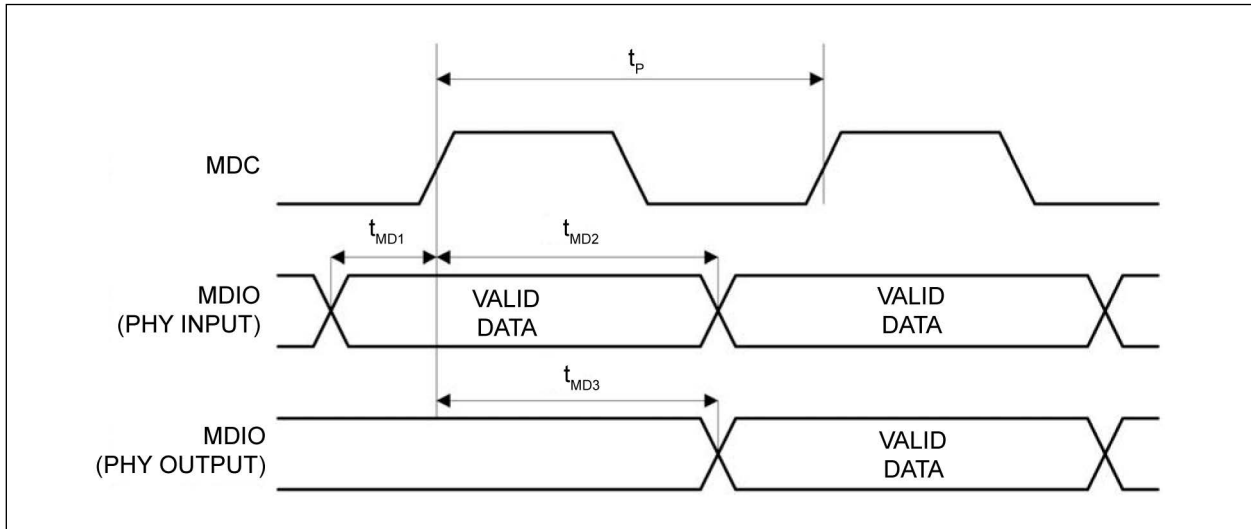

**TABLE 7-3: MDC/MDIO TIMING PARAMETERS**

Timing Parameter	Description	Min.	Typ.	Max.	Units
$t_p$	MDC period	120	400	—	ns
$t_{MD1}$	MDIO (PHY input) setup to rising edge of MDC	10	—	—	
$t_{MD2}$	MDIO (PHY input) hold from rising edge of MDC	10	—	—	
$t_{MD3}$	MDIO (PHY output) delay from rising edge of MDC	0	—	—	

The typical MDC clock frequency is 2.5 MHz (400 ns clock period).

The KSZ9031RNX can operate with MDC clock frequencies generated from bit banging with GPIO pin in the 10s/100s of Hertz and have been tested up to a MDC clock frequency of 8.33 MHz (120 ns clock period). Test condition for 8.33 MHz is for one KSZ9031RNX PHY on the MDIO line with a 1.0 k $\Omega$  pull-up to the DVDDH supply rail.

# KSZ9031RNX

**FIGURE 7-5: POWER-UP/POWER-DOWN/RESET TIMING**

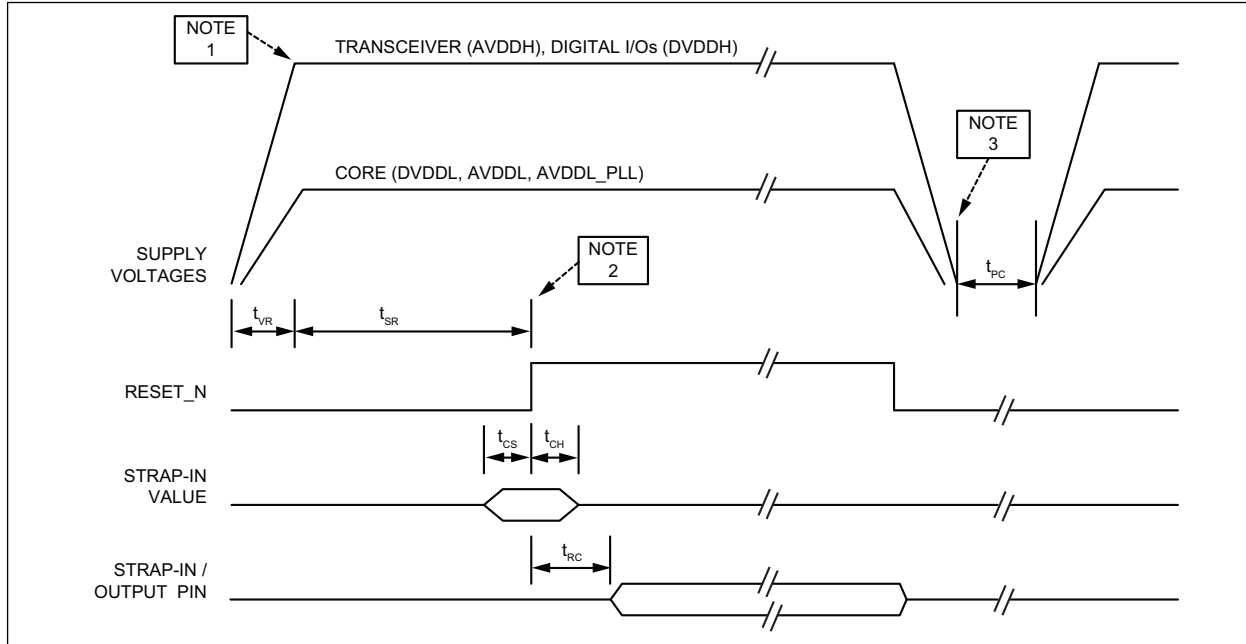

**Note 1:** The recommended power-up sequence is to have the transceiver (AVDDH) and digital I/O (DVDDH) voltages power up before the 1.2V core (DVDDL, AVDDL, AVDDL\_PLL) voltage. If the 1.2V core must power up first, the maximum lead time for the 1.2V core voltage with respect to the transceiver and digital I/O voltages should be 200  $\mu$ s.

There is no power sequence requirement between transceiver (AVDDH) and digital I/O (DVDDH) power rails.

The power-up waveforms should be monotonic for all supply voltages to the KSZ9031RNX.

**Note 2:** After the de-assertion of reset, wait a minimum of 100  $\mu$ s before starting programming on the MIIM (MDC/MDIO) interface.

**Note 3:** The recommended power-down sequence is to have the 1.2V core voltage power-down before powering down the transceiver and digital I/O voltages.

Before the next power-up cycle, all supply voltages to the KSZ9031RNX should reach less than 0.4V and there should be a minimum wait time of 150 ms from power-off to power-on.

**TABLE 7-4: POWER-UP/POWER-DOWN/RESET TIMING PARAMETERS**

Timing Parameter	Description	Min.	Typ.	Max.	Units
$t_{VR}$	Supply voltages rise time (must be monotonic)	200	—	—	$\mu$ s
$t_{SR}$	Stable supply voltages to de-assertion of reset	10	—	—	ms
$t_{CS}$	Strap-in pin configuration setup time	5	—	—	ns
$t_{CH}$	Strap-in pin configuration hold time	5	—	—	
$t_{RC}$	De-assertion of reset to strap-in pin output	6	—	—	
$t_{PC}$	Supply voltages cycle off-to-on time	150	—	—	ms

## 8.0 RESET CIRCUIT

The following are some reset circuit suggestions.

Figure 8-1 illustrates the reset circuit for powering up the KSZ9031RNX if reset is triggered by the power supply.

**FIGURE 8-1: RESET CIRCUIT IF TRIGGERED BY THE POWER SUPPLY**

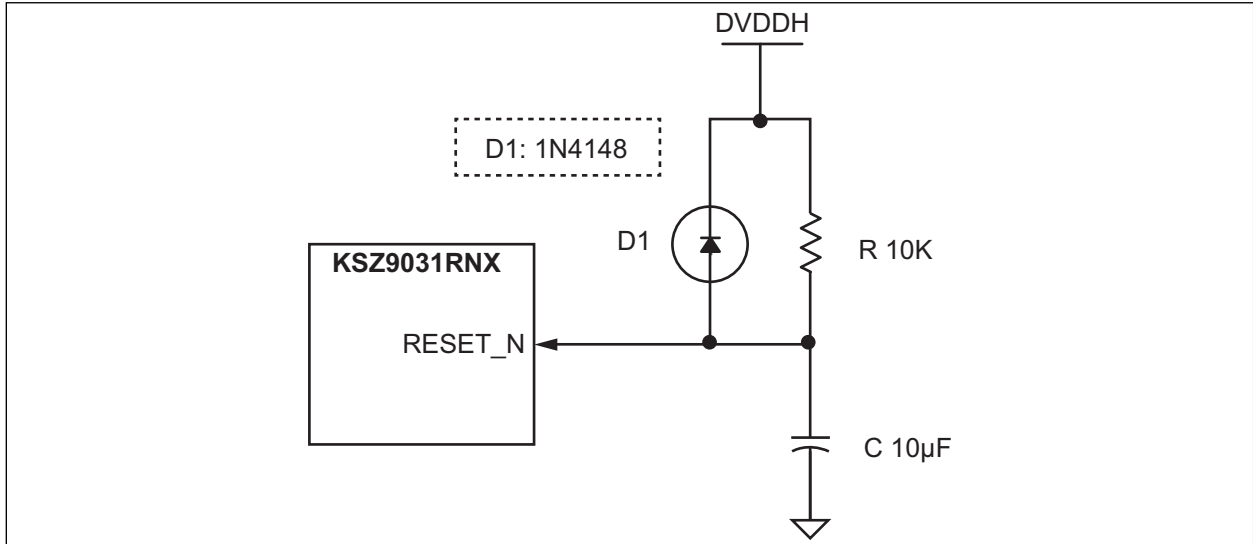

Figure 8-2 illustrates the reset circuit for applications where reset is driven by another device (for example, the CPU or an FPGA). At power-on-reset, R, C, and D1 provide the monotonic rise time to reset the KSZ9031RNX device. The RST\_OUT\_N from the CPU/FPGA provides the warm reset after power-up.

The KSZ9031RNX and CPU/FPGA references the same digital I/O voltage (DVDDH).

**FIGURE 8-2: RECOMMENDED RESET CIRCUIT FOR CPU/FPGA RESET OUTPUT**

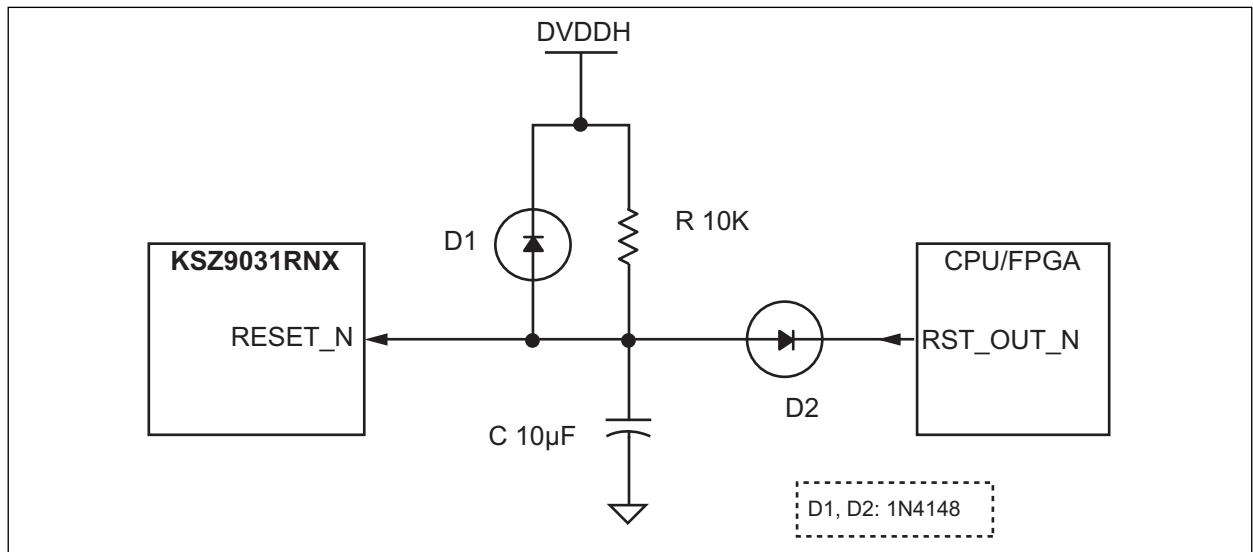
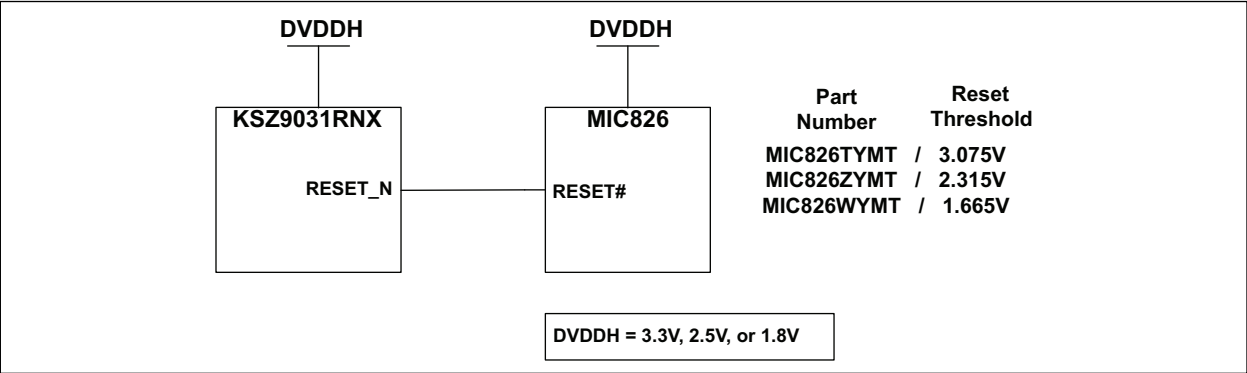

Figure 8-3 illustrates the reset circuit with an MIC826 voltage supervisor driving the KSZ9031RNX reset input.

# KSZ9031RNX

FIGURE 8-3: RESET CIRCUIT WITH MIC826 VOLTAGE SUPERVISOR



## 9.0 REFERENCE CIRCUITS — LED STRAP-IN PINS

The pull-up and pull-down reference circuits for the LED2/PHYAD1 and LED1/PHYAD0 strapping pins are shown in Figure 9-1 for 3.3V and 2.5V DVDDH.

**FIGURE 9-1: REFERENCE CIRCUITS FOR LED STRAPPING PINS**

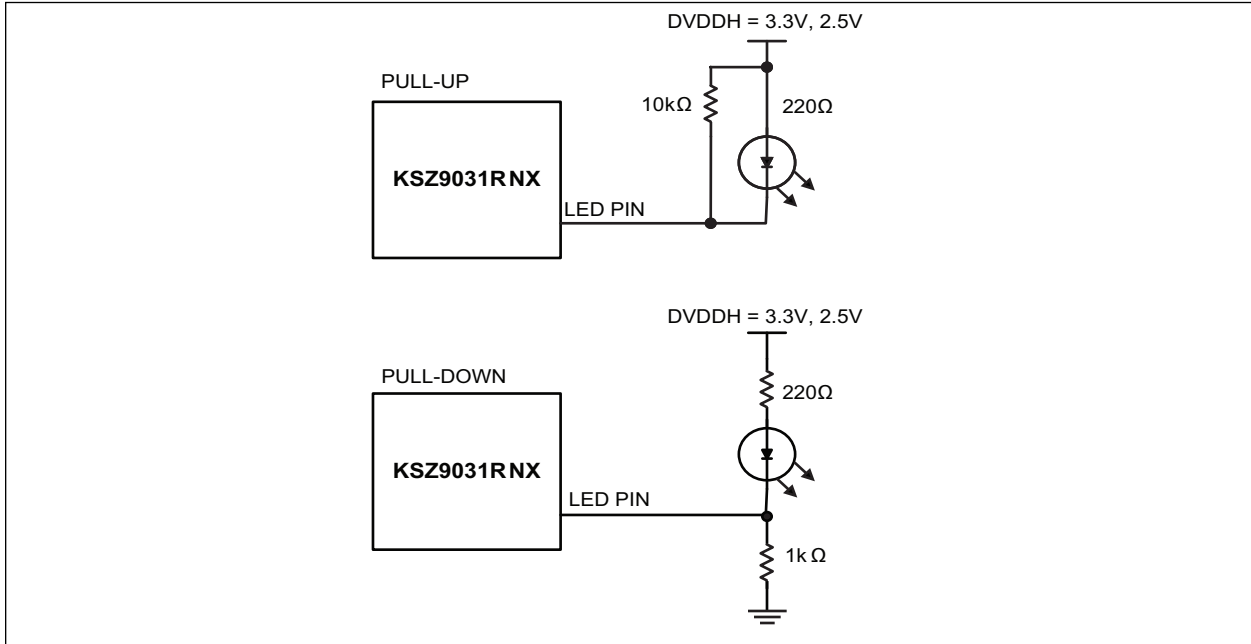

For 1.8V DVDDH, LED indication support requires voltage level shifters between LED[2:1] pins and LED indicator diodes to ensure the multiplexed PHYAD[1:0] strapping pins are latched in high/low correctly. If LED indicator diodes are not implemented, the PHYAD[1:0] strapping pins just need 10 kΩ pull-up to 1.8V DVDDH for a value of 1, and 1.0 kΩ pull-down to ground for a value of 0.

# KSZ9031RNX

## 10.0 REFERENCE CLOCK - CONNECTION AND SELECTION

A crystal or external clock source, such as an oscillator, is used to provide the reference clock for the KSZ9031RNX. The reference clock is 25 MHz for all operating modes of the KSZ9031RNX.

The KSZ9031RNX uses the AVDDH supply, analog 3.3V (or analog 2.5V option for commercial temperature only), for the crystal/clock pins (XI, XO). If the 25 MHz reference clock is provided externally, the XI input pin should have a minimum clock voltage peak-to-peak ( $V_{PP}$ ) swing of 2.5V reference to ground. If  $V_{PP}$  is less than 2.5V, series capacitive coupling is recommended. With capacitive coupling, the  $V_{PP}$  swing can be down to 1.5V. Maximum  $V_{PP}$  swing is 3.3V +5%.

Figure 10-1 and Table 10-1 show the reference clock connection to XI and XO of the KSZ9031RNX, and the reference clock selection criteria.

**FIGURE 10-1: 25 MHZ CRYSTAL/OSCILLATOR REFERENCE CLOCK CONNECTION**

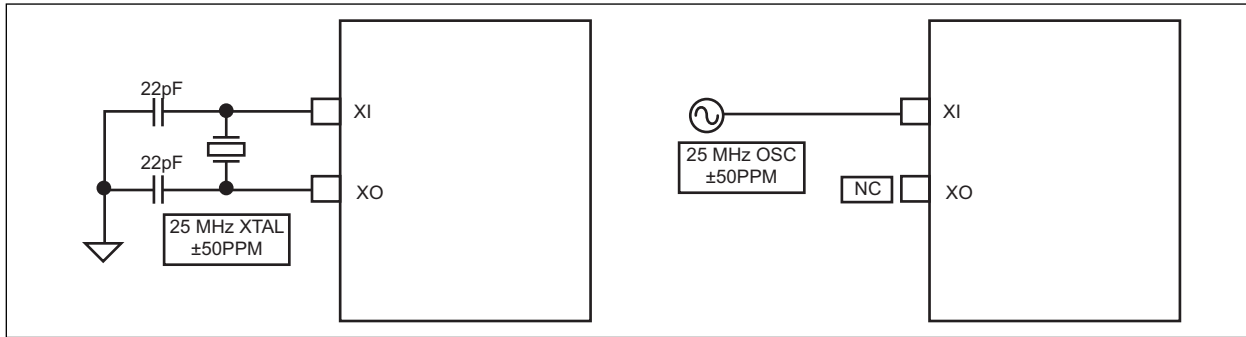

**TABLE 10-1: 25 MHZ CRYSTAL/REFERENCE CLOCK SELECTION CRITERIA**

Characteristics	Value
Frequency	25 MHz
Frequency Tolerance (max.)	±50 ppm
Crystal Series Resistance (typ.)	40Ω
Total Period Jitter (peak-to-peak)	<100 ps

## 11.0 ON-CHIP LDO CONTROLLER - MOSFET SELECTION

If the optional LDO controller is used to generate 1.2V for the core voltage, the selected MOSFET should exceed the following minimum requirements:

- P-channel
- 500 mA (continuous current)
- 3.3V or 2.5V (source – input voltage)
- 1.2V (drain – output voltage)
- $V_{GS}$  in the range of:
  - (-1.2V to -1.5V) @ 500 mA for 3.3V source voltage
  - (-1.0V to -1.1V) @ 500 mA for 2.5V source voltage

The  $V_{GS}$  for the MOSFET needs to be operating in the constant current saturated region, and not towards the  $V_{GS(th)}$ , the threshold voltage for the cut-off region of the MOSFET.

See Table 6-11 for LDO controller output driving range to the gate input of the MOSFET.

Refer to application note ANLAN206 – KSZ9031 Gigabit PHY Optimized Power Scheme for High Efficiency, Low-Power Consumption and Dissipation as a design reference.

## 12.0 MAGNETIC - CONNECTION AND SELECTION

A 1:1 isolation transformer is required at the line interface. Use one with integrated common-mode chokes for designs exceeding FCC requirements. An optional auto-transformer stage following the chokes provides additional common-mode noise and signal attenuation.

The KSZ9031RNX design incorporates voltage-mode transmit drivers and on-chip terminations.

With the voltage-mode implementation, the transmit drivers supply the common-mode voltages to the four differential pairs. Therefore, the four transformer center tap pins on the KSZ9031RNX side should not be connected to any power supply source on the board; rather, the center tap pins should be separated from one another and connected through separate 0.1  $\mu\text{F}$  common-mode capacitors to ground. Separation is required because the common-mode voltage could be different between the four differential pairs, depending on the connected speed mode.

Figure 12-1 shows the typical gigabit magnetic interface circuit for the KSZ9031RNX.

**FIGURE 12-1: TYPICAL GIGABIT MAGNETIC INTERFACE CIRCUIT**

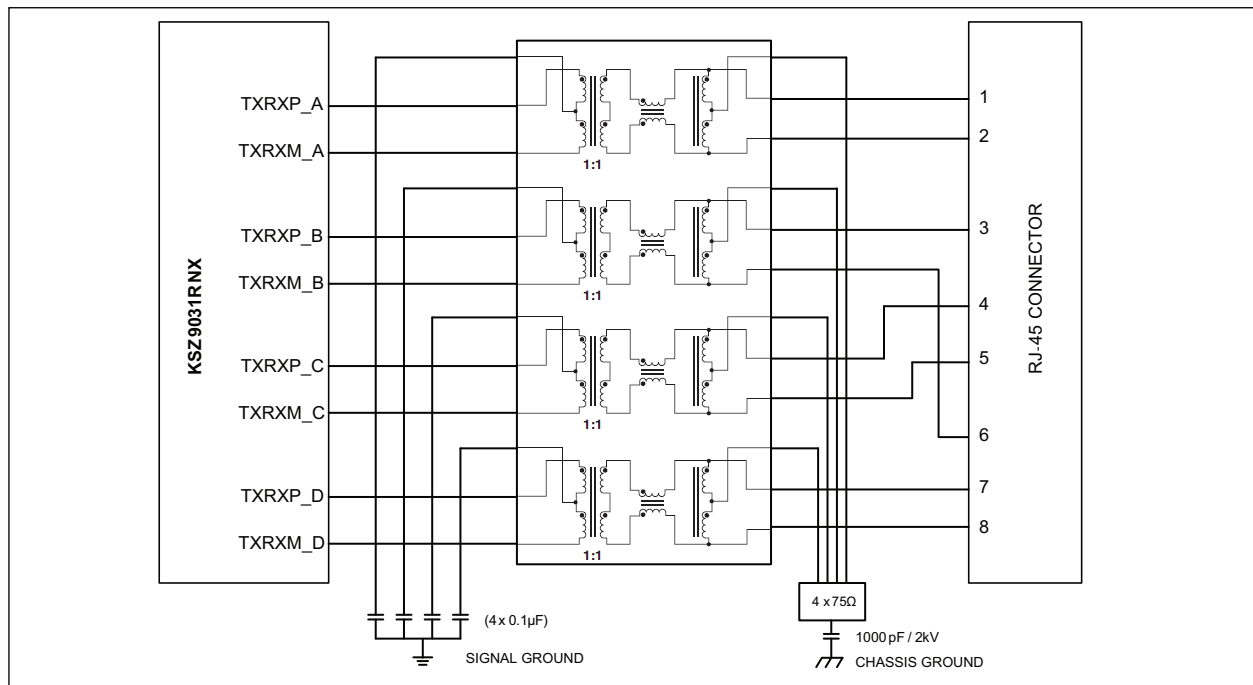

Table 12-1 lists recommended magnetic characteristics.

**TABLE 12-1: MAGNETICS SELECTION CRITERIA**

Parameter	Value	Test Conditions
Turns Ratio	1 CT : 1 CT	—
Open-Circuit Inductance (min.)	350 $\mu\text{H}$	100 mV, 100 kHz, 8 mA
Insertion Loss (max.)	1.0 dB	0 MHz to 100 MHz
HIPOT (min.)	1500 $V_{\text{RMS}}$	—

Table 12-2 is a list of compatible single-port magnetics with separated transformer center tap pins on the G-PHY chip side that can be used with the KSZ9031RNX.

**TABLE 12-2: COMPATIBLE SINGLE-PORT 10/100/1000 MAGNETICS**

Manufacturer	Part Number	Auto-Transformer	Temperature Range	Magnetic + RJ-45
Bel Fuse	0826-1G1T-23-F	Yes	0°C to 70°C	Yes
HALO	TG1G-E001NZRL	No	-40°C to 85°C	No

# KSZ9031RNX

---

---

**TABLE 12-2: COMPATIBLE SINGLE-PORT 10/100/1000 MAGNETICS (CONTINUED)**

<b>Manufacturer</b>	<b>Part Number</b>	<b>Auto-Transformer</b>	<b>Temperature Range</b>	<b>Magnetic + RJ-45</b>
HALO	TG1G-S001NZRL	No	0°C to 70°C	No
HALO	TG1G-S002NZRL	Yes	0°C to 70°C	No
Pulse	H5007NL	Yes	0°C to 70°C	No
Pulse	H5062NL	Yes	0°C to 70°C	No
Pulse	HX5008NL	Yes	-40°C to 85°C	No
Pulse	JK0654219NL	Yes	0°C to 70°C	Yes
Pulse	JK0-0136NL	No	0°C to 70°C	Yes
TDK	TLA-7T101LF	No	0°C to 70°C	No
Würth/Midcom	000-7093-37R-LF1	Yes	0°C to 70°C	No

## 13.0 PACKAGE OUTLINES

**Note:** For the most current package drawings, please see the Microchip Packaging Specification located at <http://www.microchip.com/packaging>

**FIGURE 13-1: 48-LEAD VERY THIN PLASTIC QUAD FLAT, NO LEAD PACKAGE (PVA) - 7 MM X 7 MM X 0.9 MM BODY [VQFN] WITH 3.5 MM X 3.5 MM EXPOSED PAD; MICREL LEGACY PACKAGE MLF77Q-48L (DRAWING)**

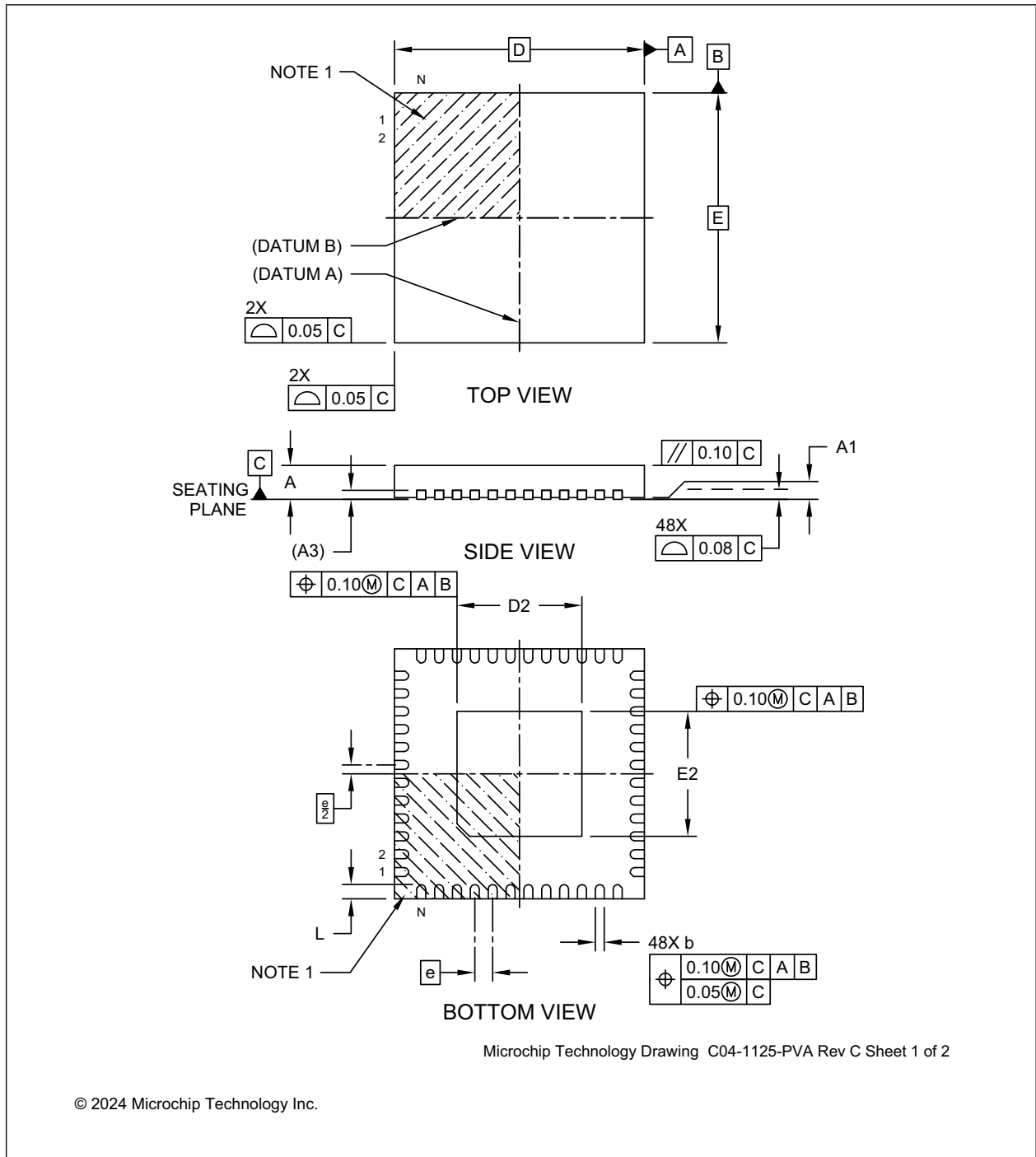

# KSZ9031RNX

**Note:** For the most current package drawings, please see the Microchip Packaging Specification located at <http://www.microchip.com/packaging>

**FIGURE 13-2: 48-LEAD VERY THIN PLASTIC QUAD FLAT, NO LEAD PACKAGE (PVA) - 7 MM X 7 MM X 0.9 MM BODY [VQFN] WITH 3.5 MM X 3.5 MM EXPOSED PAD; MICREL LEGACY PACKAGE MLF77Q-48L (DIMENSIONS)**

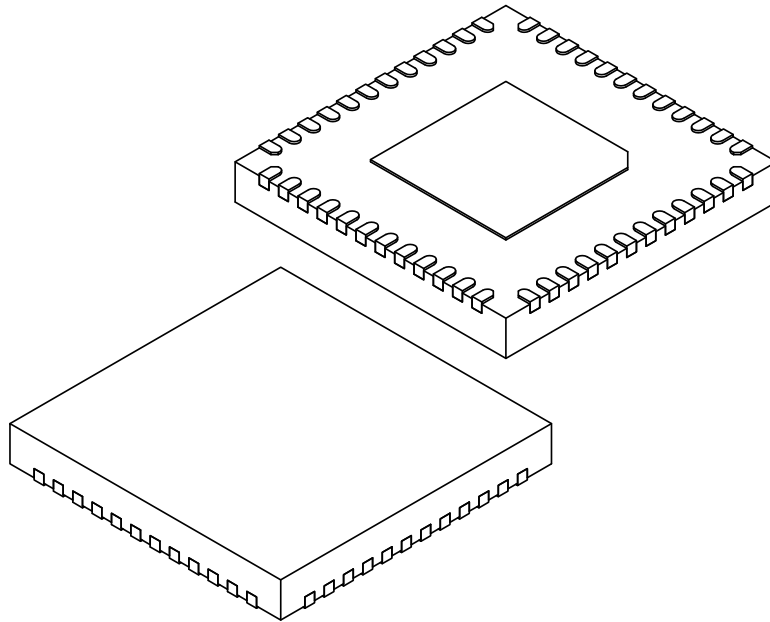

Dimension Limits	Units	MILLIMETERS		
		MIN	NOM	MAX
Number of Terminals	N	48		
Pitch	e	0.50 BSC		
Overall Height	A	0.80	0.90	1.00
Standoff	A1	0.00	0.02	0.05
Terminal Thickness	A3	0.203 REF		
Overall Length	D	7.00 BSC		
Exposed Pad Length	D2	3.40	3.50	3.60
Overall Width	E	7.00 BSC		
Exposed Pad Width	E2	3.40	3.50	3.60
Terminal Width	b	0.18	0.25	0.30
Terminal Length	L	0.30	0.40	0.50

**Notes:**

- Pin 1 visual index feature may vary, but must be located within the hatched area.
- Package is saw singulated
- Dimensioning and tolerancing per ASME Y14.5M  
 BSC: Basic Dimension. Theoretically exact value shown without tolerances.  
 REF: Reference Dimension, usually without tolerance, for information purposes only.

Microchip Technology Drawing C04-1125-PVA Rev C Sheet 2 of 2

© 2024 Microchip Technology Inc.

**Note:** For the most current package drawings, please see the Microchip Packaging Specification located at <http://www.microchip.com/packaging>

**FIGURE 13-3: 48-LEAD VERY THIN PLASTIC QUAD FLAT, NO LEAD PACKAGE (PVA) - 7 MM X 7 MM X 0.9 MM BODY [VQFN] WITH 3.5 MM X 3.5 MM EXPOSED PAD; MICREL LEGACY PACKAGE MLF77Q-48L (LAND PATTERN)**

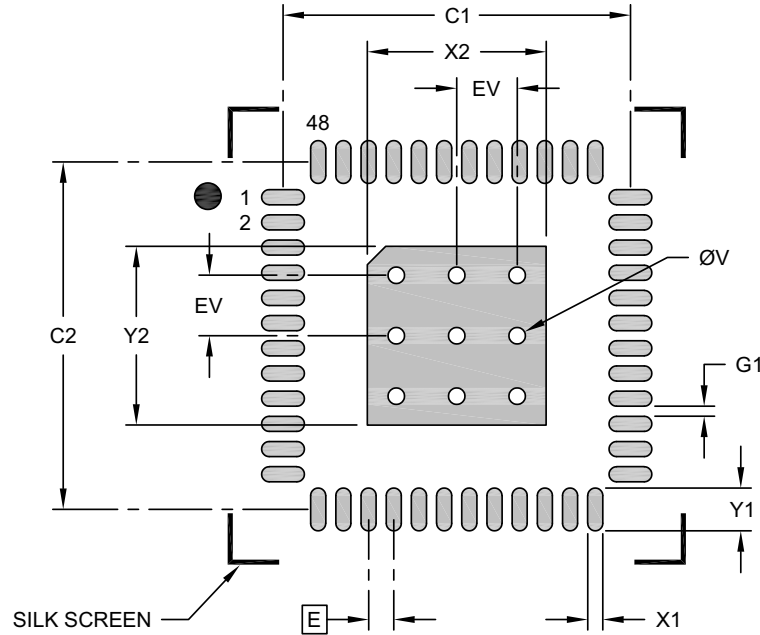

**RECOMMENDED LAND PATTERN**

Dimension Limits	Units	MILLIMETERS		
		MIN	NOM	MAX
Contact Pitch	E	0.50 BSC		
Optional Center Pad Width	X2			3.60
Optional Center Pad Length	Y2			3.60
Contact Pad Spacing	C1		6.90	
Contact Pad Spacing	C2		6.90	
Contact Pad Width (X48)	X1			0.30
Contact Pad Length (X48)	Y1			0.85
Contact Pad to Contact Pad (X44)	G1	0.20		
Thermal Via Diameter	V		0.33	
Thermal Via Pitch	EV		1.20	

**Notes:**

- Dimensioning and tolerancing per ASME Y14.5M  
BSC: Basic Dimension. Theoretically exact value shown without tolerances.
- For best soldering results, thermal vias, if used, should be filled or tented to avoid solder loss during reflow process

Microchip Technology Drawing C04-3125-PVA Rev C

© 2024 Microchip Technology Inc.

# KSZ9031RNx

**Note:** For the most current package drawings, please see the Microchip Packaging Specification located at <http://www.microchip.com/packaging>

**FIGURE 13-4: 48-LEAD VERY THIN PLASTIC QUAD FLAT NO LEAD PACKAGE (PUA) - 7 MM X 7 MM X 1.0 MM BODY (VQFN) WITH 5.05 MM X 5.05 MM EXPOSED PAD AND STEPPED WETTABLE FLANKS (DRAWING)**

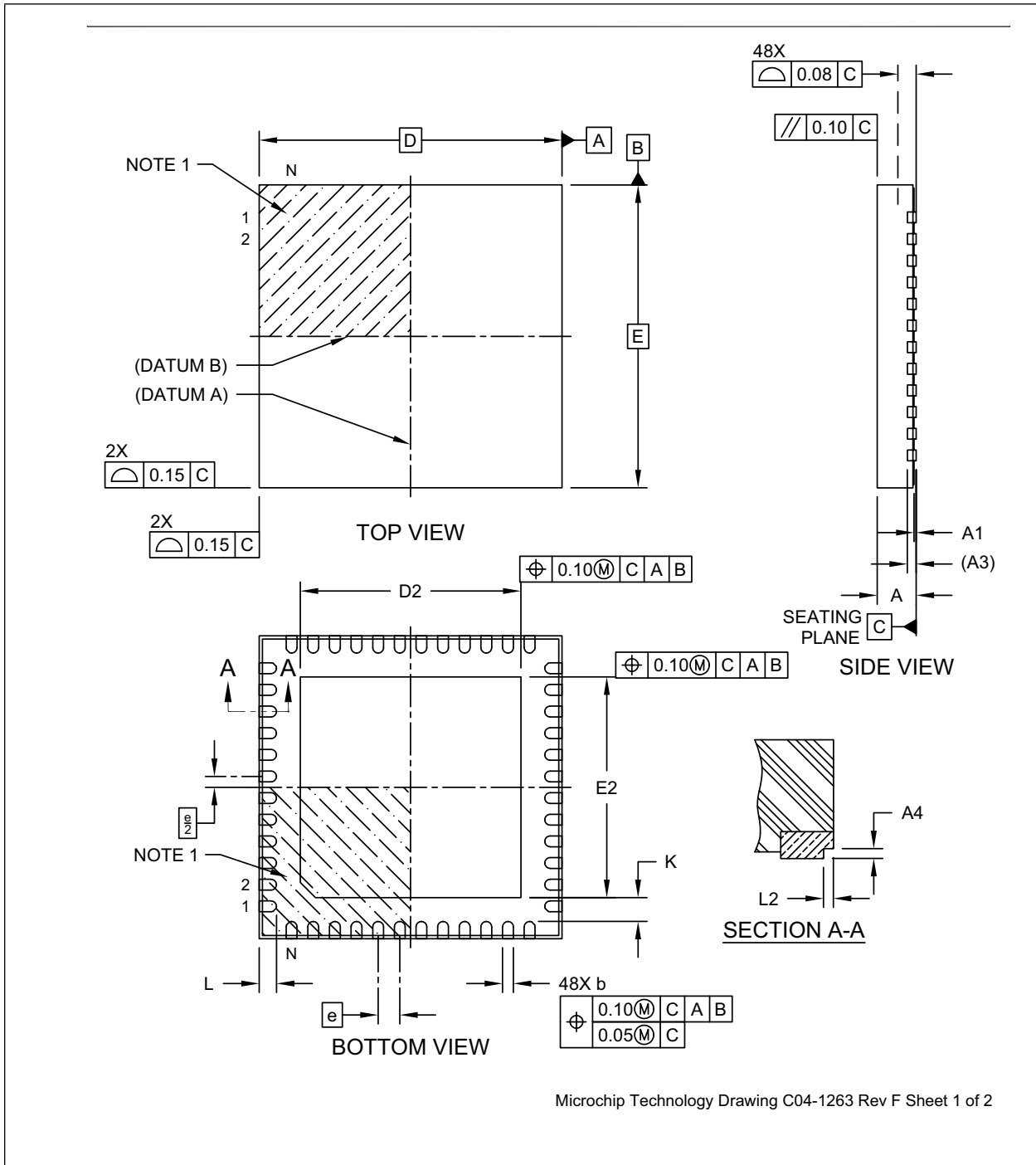

Microchip Technology Drawing C04-1263 Rev F Sheet 1 of 2

**Note:** For the most current package drawings, please see the Microchip Packaging Specification located at <http://www.microchip.com/packaging>

**FIGURE 13-5: 48-LEAD VERY THIN PLASTIC QUAD FLAT NO LEAD PACKAGE (PUA) - 7 MM X 7 MM X 1.0MM BODY (VQFN) WITH 5.05 MM X 5.05 MM EXPOSED PAD AND STEPPED WETTABLE FLANKS (DIMENSIONS)**

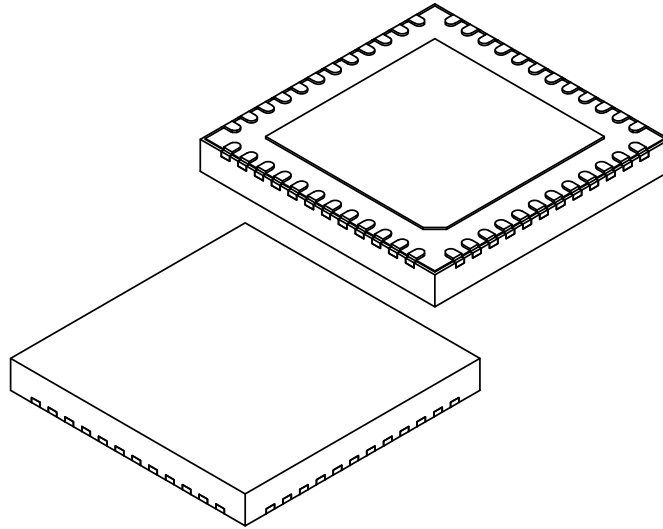

Dimension Limits	Units	MILLIMETERS		
		MIN	NOM	MAX
Number of Terminals	N	48		
Pitch	e	0.50 BSC		
Overall Height	A	0.80	0.90	1.00
Standoff	A1	0.00	0.035	0.05
Terminal Thickness	A3	0.203 REF		
Overall Length	D	7.00 BSC		
Exposed Pad Length	D2	4.90	5.05	5.20
Overall Width	E	7.00 BSC		
Exposed Pad Width	E2	4.90	5.05	5.20
Terminal Width	b	0.20	0.25	0.30
Terminal Length	L	0.35	0.40	0.45
Terminal-to-Exposed-Pad	K	0.20	-	-
Step Cut Height	A4	0.075	-	-
Step Cut Length	L2	-	-	0.075
Alternate Stepped Wettable Flank Dimensions				
Step Cut Height	A4	0.10	-	0.19
Step Cut Length	L2	-	-	0.085

**Notes:**

- Pin 1 visual index feature may vary, but must be located within the hatched area.
- Package is saw singulated
- Dimensioning and tolerancing per ASME Y14.5M  
 BSC: Basic Dimension. Theoretically exact value shown without tolerances.  
 REF: Reference Dimension, usually without tolerance, for information purposes only.

Microchip Technology Drawing C04-1263 Rev F Sheet 2 of 2

# KSZ9031RNX

**Note:** For the most current package drawings, please see the Microchip Packaging Specification located at <http://www.microchip.com/packaging>

**FIGURE 13-6: 48-LEAD VQFN 7 MM X 7 MM X 1.0MM PACKAGE (WETTABLE FLANK) WITH 5.05 MM X 5.05 MM EXPOSED PAD AREA RECOMMENDED (LAND PATTERN)**

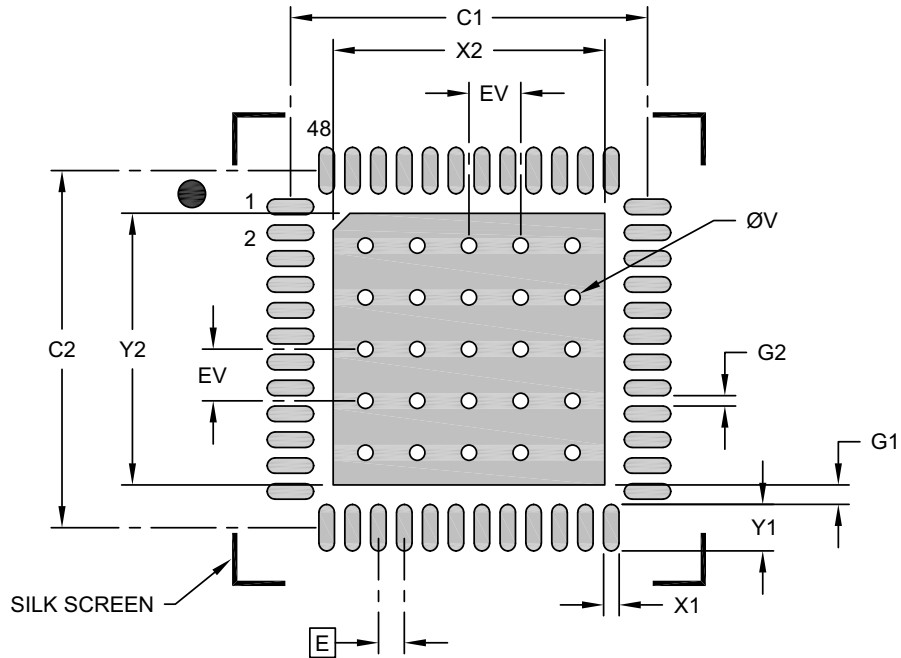

## RECOMMENDED LAND PATTERN

Dimension Limits	Units	MILLIMETERS		
		MIN	NOM	MAX
Contact Pitch	E	0.50 BSC		
Optional Center Pad Width	X2			5.20
Optional Center Pad Length	Y2			5.20
Contact Pad Spacing	C1		6.90	
Contact Pad Spacing	C2		6.90	
Contact Pad Width (X48)	X1			0.30
Contact Pad Length (X48)	Y1			0.90
Contact Pad to Center Pad (X48)	G1	0.43		
Contact Pad to Contact Pad (X44)	G2	0.20		
Thermal Via Diameter	V		0.30	
Thermal Via Pitch	EV		1.00	

**Notes:**

- Dimensioning and tolerancing per ASME Y14.5M  
BSC: Basic Dimension. Theoretically exact value shown without tolerances.
- For best soldering results, thermal vias, if used, should be filled or tented to avoid solder loss during reflow process

Microchip Technology Drawing C04-3263 Rev F

**Note:** For the most current package drawings, please see the Microchip Packaging Specification located at <http://www.microchip.com/packaging>

**FIGURE 13-7: 48-LEAD VERY THIN PLASTIC QUAD FLAT NO LEAD PACKAGE (PSA) 7 MM X 7 MM X 1.0 MM BODY (VQFN) WITH 5.05 MM X 5.05 MM EXPOSED PAD (DRAWING)**

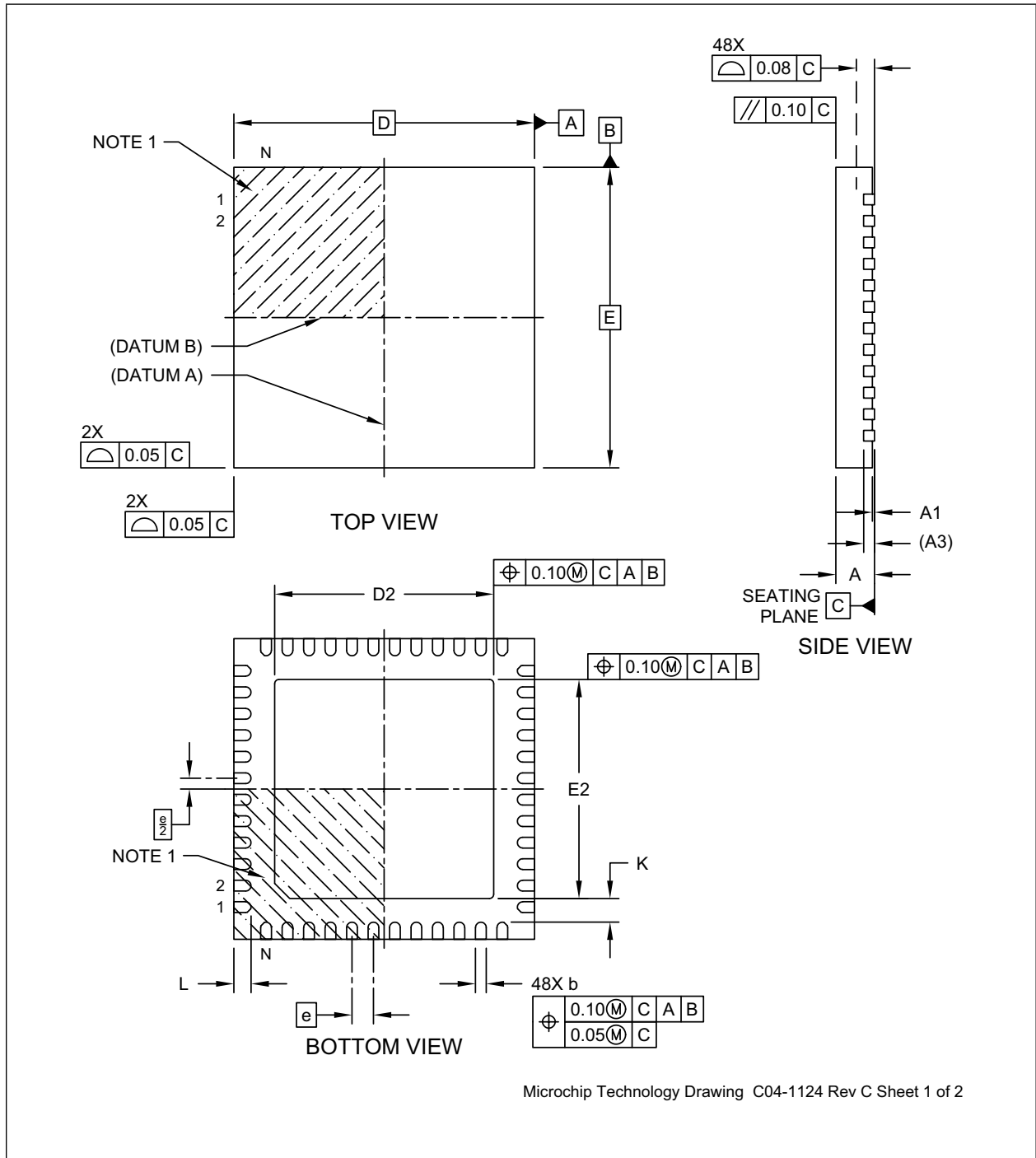

# KSZ9031RNX

**Note:** For the most current package drawings, please see the Microchip Packaging Specification located at <http://www.microchip.com/packaging>

**FIGURE 13-8: 48-LEAD VERY THIN PLASTIC QUAD FLAT NO LEAD PACKAGE (PSA) 7 MM X 7 MM X 1.0 MM BODY (VQFN) WITH 5.05 MM X 5.05 MM EXPOSED PAD (DIMENSIONS)**

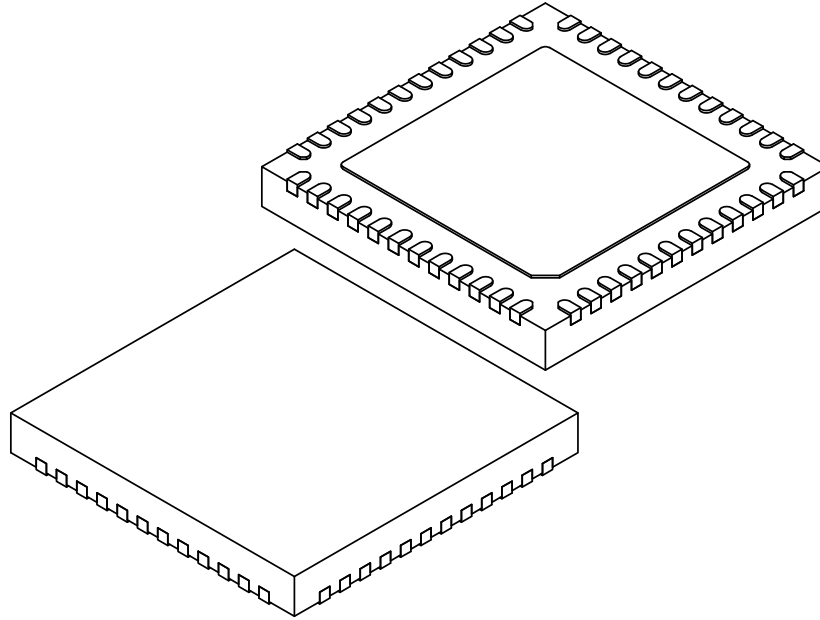

Dimension Limits	Units	MILLIMETERS		
		MIN	NOM	MAX
Number of Terminals	N	48		
Pitch	e	0.50 BSC		
Overall Height	A	0.80	0.90	1.00
Standoff	A1	0.00	0.02	0.05
Terminal Thickness	A3	0.253 REF		
Overall Length	D	7.00 BSC		
Exposed Pad Length	D2	4.90	5.05	5.20
Overall Width	E	7.00 BSC		
Exposed Pad Width	E2	4.90	5.05	5.20
Terminal Width	b	0.20	0.25	0.30
Terminal Length	L	0.35	0.40	0.45
Terminal-to-Exposed-Pad	K	0.20	-	-

**Notes:**

- Pin 1 visual index feature may vary, but must be located within the hatched area.
- Package is saw singulated
- Dimensioning and tolerancing per ASME Y14.5M  
 BSC: Basic Dimension. Theoretically exact value shown without tolerances.  
 REF: Reference Dimension, usually without tolerance, for information purposes only.

Microchip Technology Drawing C04-1124 Rev C Sheet 2 of 2

**Note:** For the most current package drawings, please see the Microchip Packaging Specification located at <http://www.microchip.com/packaging>

**FIGURE 13-9: 48-LEAD VERY THIN PLASTIC QUAD FLAT NO LEAD PACKAGE (PSA) 7 MM X 7 MM X 1.0 MM BODY (VQFN) WITH 5.05 MM X 5.05 MM EXPOSED PAD (LAND PATTERN)**

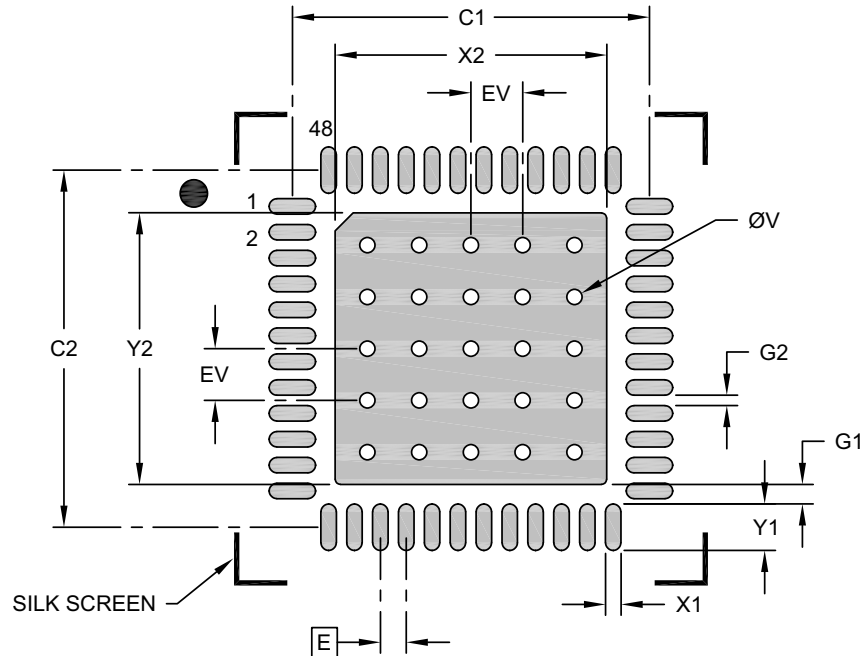

### RECOMMENDED LAND PATTERN

Dimension Limits	Units	MILLIMETERS		
		MIN	NOM	MAX
Contact Pitch	E	0.50 BSC		
Optional Center Pad Width	X2			5.20
Optional Center Pad Length	Y2			5.20
Contact Pad Spacing	C1		6.90	
Contact Pad Spacing	C2		6.90	
Contact Pad Width (X48)	X1			0.30
Contact Pad Length (X48)	Y1			0.90
Contact Pad to Center Pad (X48)	G1	0.43		
Contact Pad to Contact Pad (X44)	G2	0.20		
Thermal Via Diameter	V		0.30	
Thermal Via Pitch	EV		1.00	

**Notes:**

- Dimensioning and tolerancing per ASME Y14.5M  
BSC: Basic Dimension. Theoretically exact value shown without tolerances.
- For best soldering results, thermal vias, if used, should be filled or tented to avoid solder loss during reflow process

Microchip Technology Drawing C04-3124 Rev C

# KSZ9031RNX

## APPENDIX A: DATA SHEET REVISION HISTORY

TABLE A-1: REVISION HISTORY

Revision	Section/Figure/Entry	Correction
DS00002117K (07-09-24)	Package Outlines	Added/Updated PVA package outlines.
	Product Identification System	Updated bondwire configurations.
DS00002117J (04-26-22)	Table 3-5, "Delay for 5-Bit Pad Skew Setting"	Updated to remove the word "Absolute" from table title, as the values are actually relative to the default.
	Table 3-6, "Delay for 4-Bit Pad Skew Setting"	Removed "Absolute" from additional table title and call out.
DS00002117H (08-31-21)	Product Identification System	Bond Wire corrected: A: Gold, B or C: Gold or Copper
DS00002117G (07-23-21)	Section 13.0 "Package Outlines"	Updated package outline drawings Figure 13-7 up to Figure 13-6.
	Product Identification System on page 81	Corrections: 5.1 mm x 5.1 mm ePad -> 5.05 mm x 5.05 mm ePad.
DS00002117F (06-02-17)	Table 2-1, "Signals - KSZ9031RNX"	Added the following note to pin description for pin 43: Note: This pin should never be driven externally.
DS00002117E (05-26-17)	Product Identification System	<ul style="list-style-type: none"> <li>- Added "wetable flank lead frame" after VQFN for automotive grade ordering examples e through l.</li> <li>- Modified "automotive temperature" to automotive grade 3 temperature" for ordering example e.</li> <li>- Modified "automotive extended temperature" to "automotive grade 2 temperature" for ordering example f.</li> <li>- In note 1, replaced "module #8" with "module #11".</li> </ul>
	Section 13.0 "Package Outlines"	Updated figure titles in Figure 13-5 and Figure 13-6
	Features on page 1	Updated ordering of bulleted list. Corrections to part numbers in AEC-Q100 Grade 3 and Grade 2 part numbering.
	Target Applications on page 1	Added Industrial Control. Removed Media Converter.
	Section 1.1, "General Description," on page 4	Modified description to refer to KSZ9031RNXUA/UB and KSZ9031RNXVA/VB as the automotive part names.
	Section 5.2, "Operating Ratings**," on page 52	Modified ratings to refer to KSZ9031RNXUA/UB and KSZ9031RNXVA/VB as the automotive part names.

**TABLE A-1: REVISION HISTORY (CONTINUED)**

Revision	Section/Figure/Entry	Correction
	FIGURE 13-5: 48-Lead Very Thin Plastic Quad Flat No Lead Package (PUA) - 7 mm x 7 mm x 1.0mm Body (VQFN) with 5.05 mm x 5.05 mm Exposed Pad and Stepped wettable flanks (Dimensions) on page 73 and FIGURE 13-6: 48-Lead VQFN 7 mm x 7 mm x 1.0mm Package (wettable flank) with 5.05 mm x 5.05 mm Exposed Pad Area Recommended (Land Pattern) on page 74	New package drawings to that change WQFN to VQFN.
	Product Identification System on page 81	Corrections to PIS ordering code matrix.
DS00002117D (01-05-17)	All	Sales listing and cover pages updated. Minor text changes throughout.
	Features on page 1	Updated info for AEC-Q100 Qualified for Automotive Applications.
	Target Applications on page 1	Added Automotive In-Vehicle Networking.
	Section 5.2, "Operating Ratings**," on page 52	Updated maximum operating voltage for (DVDDL, AVDDL, AVDDL_PLL).
DS00002117C (07-26-16)	All	Removed Energy Efficient Ethernet functionality.
DS00002117B (05-24-16)	10.0 Reference Clock - Connection and Selection	Specified jitter for 25 MHz reference crystal/clock.
DS00002117A (03-14-16)		Converted Micrel data sheet KSZ9031RNX to Microchip DS00002117A. Minor text changes throughout.
	Wake-On-LAN – Customized Packet, Expected CRC 1 and CRC 2 Registers.	The “lower” and “upper” denotations for the two bytes of expected CRC are swapped in the previous revision.
	Product Identification System	Specified exposed pad size area for packages.
	Package Information	Corrected information for copper wire part numbers (KSZ9031RNXCC, KSZ9031RNXIC) to 48-pin (7 mm x 7 mm) QFN with (5.1 mm x 5.1 mm) exposed pad area. This is a data sheet correction. There is no change to the copper wire package.

# KSZ9031RNX

---

## THE MICROCHIP WEB SITE

Microchip provides online support via our WWW site at [www.microchip.com](http://www.microchip.com). This web site is used as a means to make files and information easily available to customers. Accessible by using your favorite Internet browser, the web site contains the following information:

- **Product Support** – Data sheets and errata, application notes and sample programs, design resources, user's guides and hardware support documents, latest software releases and archived software
- **General Technical Support** – Frequently Asked Questions (FAQ), technical support requests, online discussion groups, Microchip consultant program member listing
- **Business of Microchip** – Product selector and ordering guides, latest Microchip press releases, listing of seminars and events, listings of Microchip sales offices, distributors and factory representatives

## CUSTOMER CHANGE NOTIFICATION SERVICE

Microchip's customer notification service helps keep customers current on Microchip products. Subscribers will receive e-mail notification whenever there are changes, updates, revisions or errata related to a specified product family or development tool of interest.

To register, access the Microchip web site at [www.microchip.com](http://www.microchip.com). Under "Support", click on "Customer Change Notification" and follow the registration instructions.

## CUSTOMER SUPPORT

Users of Microchip products can receive assistance through several channels:

- Distributor or Representative
- Local Sales Office
- Field Application Engineer (FAE)
- Technical Support

Customers should contact their distributor, representative or Field Application Engineer (FAE) for support. Local sales offices are also available to help customers. A listing of sales offices and locations is included in the back of this document.

**Technical support is available through the web site at: <http://microchip.com/support>**

## PRODUCT IDENTIFICATION SYSTEM

To order or obtain information, e.g., on pricing or delivery, refer to the factory or the listed sales office.

<u>PART NO.</u>	<u>X</u>	<u>XX</u>	<u>X</u>	<u>X</u>	<u>-</u>	<u>XX</u>	<u>XXX</u>
Device	Interface	Package	Temp.	Bond Wire		Media Type	Automotive Option
<b>Device:</b>	KSZ9031						
<b>Interface:</b>	R	=	RGMII				
<b>Package:</b>	NX	=	48-pin QFN or VQFN				
<b>Temperature:</b>	C	=	0°C to +70°C	(Commercial)			
	I	=	-40°C to +85°C	(Industrial)			
	U	=	-40°C to +85°C	(Automotive Grade 3)			
	V	=	-40°C to +105°C	(Automotive Grade 2)			
<b>Bond Wire:</b>	A	=	PVA package, 3.5x3.5 mm ePad				
	B	=	PUA package, 5.05x5.05 mm ePad with Wettable Flank				
	C	=	PSA package, 5.05x5.05 mm ePad				
<b>Media Type:</b>	Blank	=	Standard packaging (tray)				
	TR	=	Tape and Reel <sup>(1)</sup>				
<b>Automotive Option:</b>	VAO	=	Automotive Option <sup>(1)</sup>				
<b>Note 1:</b>	KSZ9031RNXUB and KSZ9031RNXVB corrects an erratum in the respective KSZ9031RNXUA and KSZ9031RNXVA (see Module #11 in the KSZ9031RNX errata document). KSZ9031RNXUB and KSZ9031RNXVB is recommended for all new designs and is a 100% functional and pin equivalent replacement for KSZ9031RNXUA and KSZ9031RNXVA, respectively.						
<b>Examples:</b>	<ul style="list-style-type: none"> <li>a) KSZ9031RNXCA RGMII Interface 48-pin QFN non-wettable flank lead frame (Pb-Free, 3.5 mm x 3.5 mm ePad) Commercial Temperature</li> <li>b) KSZ9031RNXCC RGMII Interface 48-pin VQFN non-wettable flank lead frame (Pb-Free, 5.05 mm x 5.05 mm ePad) Commercial Temperature</li> <li>c) KSZ9031RNXIA RGMII Interface 48-pin QFN non-wettable flank lead frame (Pb-Free, 3.5 mm x 3.5 mm ePad) Industrial Temperature</li> <li>d) KSZ9031RNXIC RGMII Interface 48-pin VQFN non-wettable flank lead frame (Pb-Free, 5.05 mm x 5.05 mm ePad) Industrial Temperature</li> <li>e) KSZ9031RNXUB-VAO RGMII Interface 48-pin VQFN wettable flank lead frame Automotive Grade 3 Temperature Automotive Option</li> <li>f) KSZ9031RNXUB-TRVAO RGMII Interface 48-pin VQFN wettable flank lead frame Automotive Grade 3 Temperature Tape and Reel packaging Automotive Option</li> <li>g) KSZ9031RNXVB-VAO RGMII Interface 48-pin VQFN wettable flank lead frame Automotive Grade 2 Temperature Automotive Option</li> <li>h) KSZ9031RNXVB-TRVAO RGMII Interface 48-pin VQFN wettable flank lead frame Automotive Grade 2 Temperature Tape and Reel packaging Automotive Option</li> </ul>						

# KSZ9031RNX

---

## Note the following details of the code protection feature on Microchip products:

- Microchip products meet the specifications contained in their particular Microchip Data Sheet.
- Microchip believes that its family of products is secure when used in the intended manner, within operating specifications, and under normal conditions.
- Microchip values and aggressively protects its intellectual property rights. Attempts to breach the code protection features of Microchip product is strictly prohibited and may violate the Digital Millennium Copyright Act.
- Neither Microchip nor any other semiconductor manufacturer can guarantee the security of its code. Code protection does not mean that we are guaranteeing the product is “unbreakable”. Code protection is constantly evolving. Microchip is committed to continuously improving the code protection features of our products.

---

This publication and the information herein may be used only with Microchip products, including to design, test, and integrate Microchip products with your application. Use of this information in any other manner violates these terms. Information regarding device applications is provided only for your convenience and may be superseded by updates. It is your responsibility to ensure that your application meets with your specifications. Contact your local Microchip sales office for additional support or, obtain additional support at <https://www.microchip.com/en-us/support/design-help/client-support-services>.

THIS INFORMATION IS PROVIDED BY MICROCHIP "AS IS". MICROCHIP MAKES NO REPRESENTATIONS OR WARRANTIES OF ANY KIND WHETHER EXPRESS OR IMPLIED, WRITTEN OR ORAL, STATUTORY OR OTHERWISE, RELATED TO THE INFORMATION INCLUDING BUT NOT LIMITED TO ANY IMPLIED WARRANTIES OF NON-INFRINGEMENT, MERCHANTABILITY, AND FITNESS FOR A PARTICULAR PURPOSE, OR WARRANTIES RELATED TO ITS CONDITION, QUALITY, OR PERFORMANCE.

IN NO EVENT WILL MICROCHIP BE LIABLE FOR ANY INDIRECT, SPECIAL, PUNITIVE, INCIDENTAL, OR CONSEQUENTIAL LOSS, DAMAGE, COST, OR EXPENSE OF ANY KIND WHATSOEVER RELATED TO THE INFORMATION OR ITS USE, HOWEVER CAUSED, EVEN IF MICROCHIP HAS BEEN ADVISED OF THE POSSIBILITY OR THE DAMAGES ARE FORESEEABLE. TO THE FULLEST EXTENT ALLOWED BY LAW, MICROCHIP'S TOTAL LIABILITY ON ALL CLAIMS IN ANY WAY RELATED TO THE INFORMATION OR ITS USE WILL NOT EXCEED THE AMOUNT OF FEES, IF ANY, THAT YOU HAVE PAID DIRECTLY TO MICROCHIP FOR THE INFORMATION.

Use of Microchip devices in life support and/or safety applications is entirely at the buyer's risk, and the buyer agrees to defend, indemnify and hold harmless Microchip from any and all damages, claims, suits, or expenses resulting from such use. No licenses are conveyed, implicitly or otherwise, under any Microchip intellectual property rights unless otherwise stated.

## Trademarks

The Microchip name and logo, the Microchip logo, Adaptec, AVR, AVR logo, AVR Freaks, BesTime, BitCloud, CryptoMemory, CryptoRF, dsPIC, flexPWR, HELDO, IGLOO, JukeBlox, KeeLoq, Kleer, LANCheck, LinkMD, maxStylus, maxTouch, MediaLB, megaAVR, Microsemi, Microsemi logo, MOST, MOST logo, MPLAB, OptoLyzr, PIC, picoPower, PICSTART, PIC32 logo, PolarFire, Prochip Designer, QTouch, SAM-BA, SenGenuity, SpyNIC, SST, SST Logo, SuperFlash, Symmetricom, SyncServer, Tachyon, TimeSource, tinyAVR, UNI/O, Vectron, and XMEGA are registered trademarks of Microchip Technology Incorporated in the U.S.A. and other countries.

AgileSwitch, ClockWorks, The Embedded Control Solutions Company, EtherSynch, Flashtec, Hyper Speed Control, HyperLight Load, Libero, motorBench, mTouch, Powermite 3, Precision Edge, ProASIC, ProASIC Plus, ProASIC Plus logo, Quiet-Wire, SmartFusion, SyncWorld, TimeCesium, TimeHub, TimePictra, TimeProvider, and ZL are registered trademarks of Microchip Technology Incorporated in the U.S.A.

Adjacent Key Suppression, AKS, Analog-for-the-Digital Age, Any Capacitor, AnyIn, AnyOut, Augmented Switching, BlueSky, BodyCom, Clockstudio, CodeGuard, CryptoAuthentication, CryptoAutomotive, CryptoCompanion, CryptoController, dsPICDEM, dsPICDEM.net, Dynamic Average Matching, DAM, ECAN, Espresso T1S, EtherGREEN, EyeOpen, GridTime, IdealBridge, IGaT, In-Circuit Serial Programming, ICSP, INICnet, Intelligent Paralleling, IntelliMOS,

Inter-Chip Connectivity, JitterBlocker, Knob-on-Display, MarginLink, maxCrypto, maxView, memBrain, Mindi, MiWi, MPASM, MPF, MPLAB Certified logo, MPLIB, MPLINK, mSic, MultiTRAK, NetDetach, Omniscient Code Generation, PICDEM, PICDEM.net, PICkit, PICtail, Power MOS IV, Power MOS 7, PowerSmart, PureSilicon, QMatrix, REAL ICE, Ripple Blocker, RTAX, RTG4, SAM-ICE, Serial

Quad I/O, simpleMAP, SimpliPHY, SmartBuffer, SmartHLS, SMART-I.S., storClad, SQI, SuperSwitcher, SuperSwitcher II, Switchtec, SynchroPHY, Total Endurance, Trusted Time, TSHARC, Turing, USBCheck, VariSense, VectorBlox, VeriPHY, ViewSpan, WiperLock, XpressConnect, and ZENA are trademarks of Microchip Technology Incorporated in the U.S.A. and other countries.

SQTP is a service mark of Microchip Technology Incorporated in the U.S.A.

The Adaptec logo, Frequency on Demand, Silicon Storage Technology, and Symmcom are registered trademarks of Microchip Technology Inc. in other countries.

GestIC is a registered trademark of Microchip Technology Germany II GmbH & Co. KG, a subsidiary of Microchip Technology Inc., in other countries.

All other trademarks mentioned herein are property of their respective companies.

© 2024, Microchip Technology Incorporated and its subsidiaries.

All Rights Reserved.

ISBN: 9781668349175

For information regarding Microchip's Quality Management Systems, please visit [www.microchip.com/quality](http://www.microchip.com/quality).



## Worldwide Sales and Service

### AMERICAS

**Corporate Office**  
2355 West Chandler Blvd.  
Chandler, AZ 85224-6199  
Tel: 480-792-7200  
Fax: 480-792-7277  
Technical Support:  
[http://www.microchip.com/  
support](http://www.microchip.com/support)  
Web Address:  
[www.microchip.com](http://www.microchip.com)

**Atlanta**  
Duluth, GA  
Tel: 678-957-9614  
Fax: 678-957-1455

**Austin, TX**  
Tel: 512-257-3370

**Boston**  
Westborough, MA  
Tel: 774-760-0087  
Fax: 774-760-0088

**Chicago**  
Itasca, IL  
Tel: 630-285-0071  
Fax: 630-285-0075

**Dallas**  
Addison, TX  
Tel: 972-818-7423  
Fax: 972-818-2924

**Detroit**  
Novi, MI  
Tel: 248-848-4000

**Houston, TX**  
Tel: 281-894-5983

**Indianapolis**  
Noblesville, IN  
Tel: 317-773-8323  
Fax: 317-773-5453  
Tel: 317-536-2380

**Los Angeles**  
Mission Viejo, CA  
Tel: 949-462-9523  
Fax: 949-462-9608  
Tel: 951-273-7800

**Raleigh, NC**  
Tel: 919-844-7510

**New York, NY**  
Tel: 631-435-6000

**San Jose, CA**  
Tel: 408-735-9110  
Tel: 408-436-4270

**Canada - Toronto**  
Tel: 905-695-1980  
Fax: 905-695-2078

### ASIA/PACIFIC

**Australia - Sydney**  
Tel: 61-2-9868-6733

**China - Beijing**  
Tel: 86-10-8569-7000

**China - Chengdu**  
Tel: 86-28-8665-5511

**China - Chongqing**  
Tel: 86-23-8980-9588

**China - Dongguan**  
Tel: 86-769-8702-9880

**China - Guangzhou**  
Tel: 86-20-8755-8029

**China - Hangzhou**  
Tel: 86-571-8792-8115

**China - Hong Kong SAR**  
Tel: 852-2943-5100

**China - Nanjing**  
Tel: 86-25-8473-2460

**China - Qingdao**  
Tel: 86-532-8502-7355

**China - Shanghai**  
Tel: 86-21-3326-8000

**China - Shenyang**  
Tel: 86-24-2334-2829

**China - Shenzhen**  
Tel: 86-755-8864-2200

**China - Suzhou**  
Tel: 86-186-6233-1526

**China - Wuhan**  
Tel: 86-27-5980-5300

**China - Xian**  
Tel: 86-29-8833-7252

**China - Xiamen**  
Tel: 86-592-2388138

**China - Zhuhai**  
Tel: 86-756-3210040

### ASIA/PACIFIC

**India - Bangalore**  
Tel: 91-80-3090-4444

**India - New Delhi**  
Tel: 91-11-4160-8631

**India - Pune**  
Tel: 91-20-4121-0141

**Japan - Osaka**  
Tel: 81-6-6152-7160

**Japan - Tokyo**  
Tel: 81-3-6880-3770

**Korea - Daegu**  
Tel: 82-53-744-4301

**Korea - Seoul**  
Tel: 82-2-554-7200

**Malaysia - Kuala Lumpur**  
Tel: 60-3-7651-7906

**Malaysia - Penang**  
Tel: 60-4-227-8870

**Philippines - Manila**  
Tel: 63-2-634-9065

**Singapore**  
Tel: 65-6334-8870

**Taiwan - Hsin Chu**  
Tel: 886-3-577-8366

**Taiwan - Kaohsiung**  
Tel: 886-7-213-7830

**Taiwan - Taipei**  
Tel: 886-2-2508-8600

**Thailand - Bangkok**  
Tel: 66-2-694-1351

**Vietnam - Ho Chi Minh**  
Tel: 84-28-5448-2100

### EUROPE

**Austria - Wels**  
Tel: 43-7242-2244-39  
Fax: 43-7242-2244-393

**Denmark - Copenhagen**  
Tel: 45-4485-5910  
Fax: 45-4485-2829

**Finland - Espoo**  
Tel: 358-9-4520-820

**France - Paris**  
Tel: 33-1-69-53-63-20  
Fax: 33-1-69-30-90-79

**Germany - Garching**  
Tel: 49-8931-9700

**Germany - Haan**  
Tel: 49-2129-3766400

**Germany - Heilbronn**  
Tel: 49-7131-72400

**Germany - Karlsruhe**  
Tel: 49-721-625370

**Germany - Munich**  
Tel: 49-89-627-144-0  
Fax: 49-89-627-144-44

**Germany - Rosenheim**  
Tel: 49-8031-354-560

**Israel - Hod Hasharon**  
Tel: 972-9-775-5100

**Italy - Milan**  
Tel: 39-0331-742611  
Fax: 39-0331-466781

**Italy - Padova**  
Tel: 39-049-7625286

**Netherlands - Drunen**  
Tel: 31-416-690399  
Fax: 31-416-690340

**Norway - Trondheim**  
Tel: 47-7288-4388

**Poland - Warsaw**  
Tel: 48-22-3325737

**Romania - Bucharest**  
Tel: 40-21-407-87-50

**Spain - Madrid**  
Tel: 34-91-708-08-90  
Fax: 34-91-708-08-91

**Sweden - Gothenberg**  
Tel: 46-31-704-60-40

**Sweden - Stockholm**  
Tel: 46-8-5090-4654

**UK - Wokingham**  
Tel: 44-118-921-5800  
Fax: 44-118-921-5820